





Advanced servo technology with optical network

# MELSERVO J3





## ● Servo motors

	Motor series (Note 6)	Rated speed (maximum speed) (r/min)	Rated output (kW)	Servo motor type	Global standards		Protection level	Features	Application examples
				With electro-magnetic brake (B)	EN	UL cUL			
Small capacity series	<b>HF-KP series</b> 	3000 (6000)	5 types 0.05, 0.1, 0.2, 0.4, 0.75	●	●	●	IP65 (Note 3)	<b>Low inertia</b> Perfect for general industrial machines.	<ul style="list-style-type: none"> <li>● Belt drive</li> <li>● Robots</li> <li>● Mounters</li> <li>● Sewing machines</li> <li>● X-Y tables</li> <li>● Food processing machines</li> <li>● Semiconductor manufacturing devices</li> <li>● Knitting and embroidery machines</li> </ul>
	<b>HF-MP series</b> 	3000 (6000)	5 types 0.05, 0.1, 0.2, 0.4, 0.75	●	●	●	IP65 (Note 3)	<b>Ultra-low inertia</b> Well suited for high-throughput operation.	<ul style="list-style-type: none"> <li>● Inserters</li> <li>● Mounters</li> </ul>
Medium capacity series	<b>HF-SP series</b> 	1000 (1500)	6 types 0.5, 0.85, 1.2, 2.0, 3.0, 4.2	●	● (Note 5)	● (Note 5)	IP67 (Note 3)	<b>Medium inertia</b> Two models, from low to high-speed, are available for various applications.	<ul style="list-style-type: none"> <li>● Material handling systems</li> <li>● Robots</li> <li>● X-Y tables</li> </ul>
		2000 (3000)	14 types 0.5, 1.0, 1.5, 2.0, 3.5, 5.0, 7.0 0.5, 1.0, 1.5, 2.0, 3.5, 5.0, 7.0	●	● (Note 5)	● (Note 5)	IP67 (Note 3)		
	<b>HC-LP series</b> 	2000 (3000)	5 types 0.5, 1.0, 1.5, 2.0, 3.0	●	●	●	IP65 (Note 3)	<b>Low inertia</b> Perfect for general industrial machines.	<ul style="list-style-type: none"> <li>● Roll feeders</li> <li>● Loaders and unloaders</li> <li>● High-throughput material handling systems</li> </ul>
	<b>HC-RP series</b> 	3000 (4500)	5 types 1.0, 1.5, 2.0, 3.5, 5.0	●	●	●	IP65 (Note 3)	<b>Ultra-low inertia</b> Well suited for high-throughput operation.	<ul style="list-style-type: none"> <li>● Ultra-high-throughput material handling systems</li> </ul>
Flat Medium capacity series	<b>HC-UP series</b> 	2000 (3000:0.75 to 2kW) (2500:3.5, 5kW)	5 types 0.75, 1.5, 2.0, 3.5, 5.0	●	●	●	IP65 (Note 3)	<b>Flat type</b> The flat design makes this unit well suited for situations where the installation space is restricted.	<ul style="list-style-type: none"> <li>● Robots</li> <li>● Food processing machines</li> </ul>
Medium/Large capacity series	<b>HA-LP series</b> 	1000 (1200)	16 types 6.0, 8.0, 12, 15, 20, 25, 30, 37 6.0, 8.0, 12, 15, 20, 25, 30, 37	● (Only for 6.0kW to 12kW)	● (Note 5)	● (Note 5)	IP44 (Note 3)	<b>Low inertia</b> Three models, from low to medium-speed, are available for various applications. As standard, 30kW and larger motors can be mounted either with the flange or the legs. (Note 4)	<ul style="list-style-type: none"> <li>● Injection molding machines</li> <li>● Semiconductor manufacturing equipment</li> <li>● Large material handling systems</li> <li>● Press machines</li> </ul>
		1500 (2000)	14 types 7.0, 11, 15, 22, 30, 37 7.0, 11, 15, 22, 30, 37, 45, 50	● (Only for 7.0kW to 15kW)	● (Note 5)	● (Note 5)	IP44 (Note 3)		
		2000 (2000)	14 types 5.0, 7.0, 11, 15, 22, 30, 37 11, 15, 22, 30, 37, 45, 55	● (Only for 11kW to 22kW)	● (Note 5)	● (Note 5)	IP44 IP65 for HA-LP502/702 (Note 3)		

Notes: 1. A ● mark shows production range.

2. ■ are for 400V class.

3. The shaft-through portion is excluded.

4. Some motors from 15 to 25kW capacities can be mounted with the legs. Refer to the section "Motor Dimensions" in this catalog.

5. Some motors are under application for EN, UL and cUL standards. Contact Mitsubishi for more details.

6. Actual product availability may vary according to region.

# MELSERVO-J3 The ever-evolving new

## SSCNET III, new high-speed serial bus compatible: MR-J3-B

### High-speed with high accuracy via optical communication

- Improved system responsiveness!  
The speed of exchanging data between the controller and the servo amplifier has been greatly increased thereby shortening tact time.
- Synchronized control and synchronized starting for advanced interpolation!
- Smooth control using high-speed serial communication with cycle times up to 0.44ms! (Note 1)

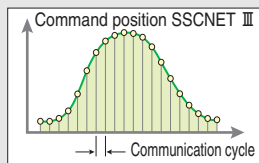
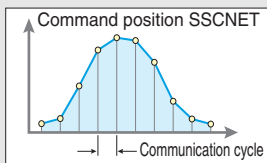

### Easy and flexible wiring with optical communication

- Capable of long distance wiring (Maximum overall distance: up to 50m between stations (Note 2) x number of axes).
- Reduced wiring by issuing the stroke limit signal and the proximity dog signal via the servo amplifier.
- Simple connection with dedicated cables, reducing both wiring time and chances of wiring errors.

### Enhanced reliability

- Improved noise resistance with optical communication!

Notes: 1. The communication cycle varies depending on the number of axes connected and the controller operation cycle.  
2. When using a long distance cable: 50m between stations x 16 axes = 800m

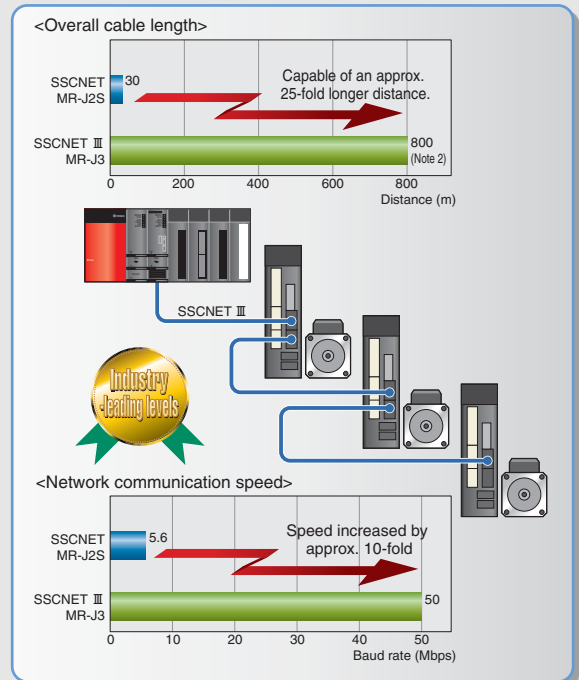

## Fully closed loop control compatible servo amplifier: MR-J3-B-RJ006

### High accuracy and high response position control

- Dual feedback control provides the highest possible positioning response by using the position feedback signals from the motor encoder during high-speed rotation, and from the load-side encoder, such as a linear encoder, when positioning (stopping).

### Flexible system structure

- With the wide variety of linear encoders, users can configure systems that meet their requirement. Compatible serial communication scale for MR-J2S can be used without modification.
- Absolute position detection system is easily structured without a battery by using a serial interface ABS type linear encoder.
- ABZ phase differential input interface unit, MR-J2S-CLP01, that was necessary for MR-J2S series, is not required when using a compatible ABZ phase pulse train interface linear encoder.

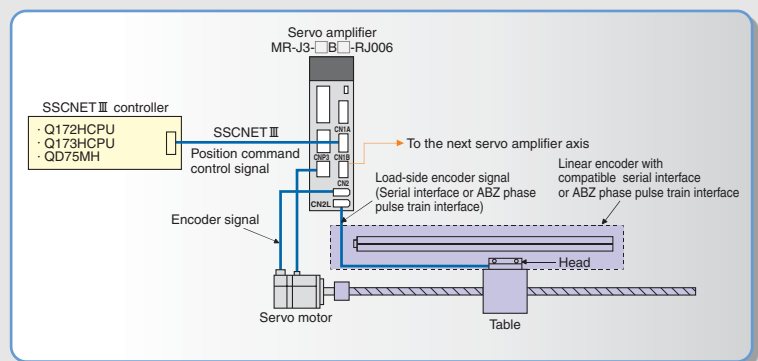

## Linear servo compatible: MR-J3-B-RJ004

### High-speed, high-accuracy

- High-speed operation (2m/s) is now possible with this direct drive system. (Conventional transmission mechanisms typically can not achieve such fast operational speeds.)
- A fully closed loop control system is realized by using position feedback signals from a machine-end encoder such as a linear encoder.

### Wide range of products

- Core and coreless type
- LM-H2 series Core type linear servo motor: Continuous thrust 60 to 960N
- LM-U2 series Coreless type linear servo motor: Continuous thrust 400 to 800N



# generation servo

## CC-Link compatible built-in positioning function: MR-J3-T

### ■ Built-in positioning function

- By setting position and speed data in the point tables in the servo amplifier, positioning operation is possible with a simple start signal from the positioning controller.

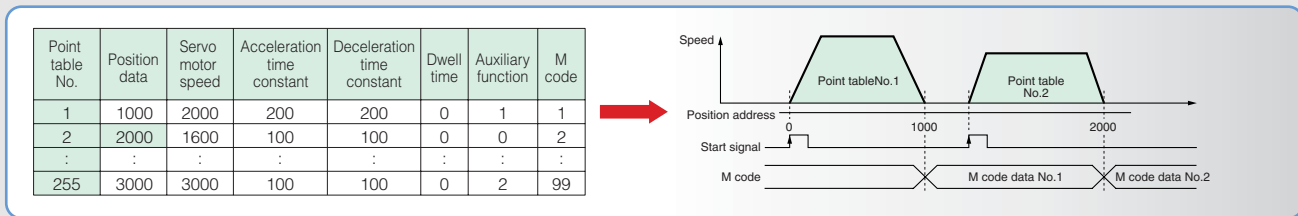

### ■ CC-Link communication compatible

- Setting position and speed data and operation start and stop is possible via CC-Link communication.
- Servo data information can be sent via CC-Link communication to the positioning controller and used for controlling the positioning application.
- CC-Link communication makes it possible to design the system with the servo amplifiers dispersed throughout.

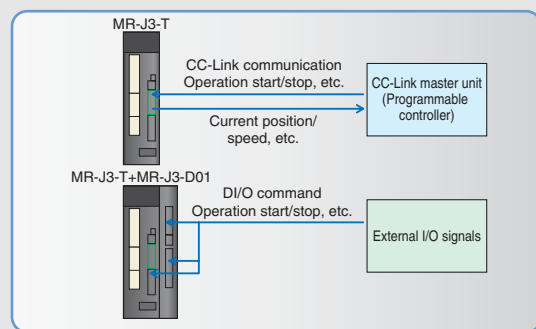

### ■ DI/O command with the extension IO unit, MR-J3-D01 (Optional)

- Selecting the point table and positioning operation start are possible by the DI command with MR-J3-D01. Also, alarm code and M code can be output with the digital signal. (CC-Link communication is not available when using MR-J3-D01.)

### ■ Parameter unit, MR-PRU03

- Parameter setting, monitoring, alarm display and test operation are possible by connecting to the servo amplifier, thus providing an efficient operation start.
- Up to 32 axes can be connected with a multi-drop system and RS-422 communication.

### ■ Special functions

- Roll feeding function.
- Indexer function (available soon)  
Capable of positioning by specifying stations (255 divisions maximum)

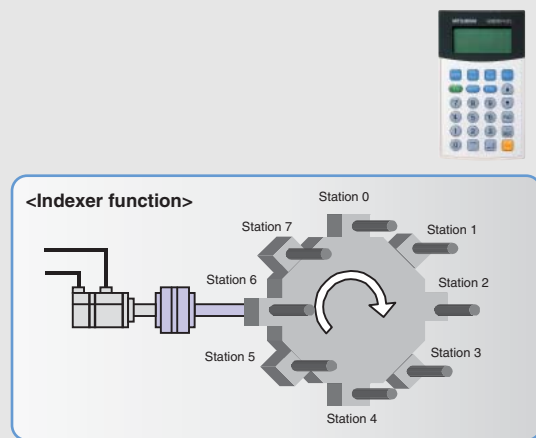

## Wide range of product lines

### ■ Diverse motor capacities

- Large capacity motors have been added to our product line. Now motors are available from 50W to 55kW. With the wide selection of motors provided, full retrofit of an MR-J2S series system is possible.

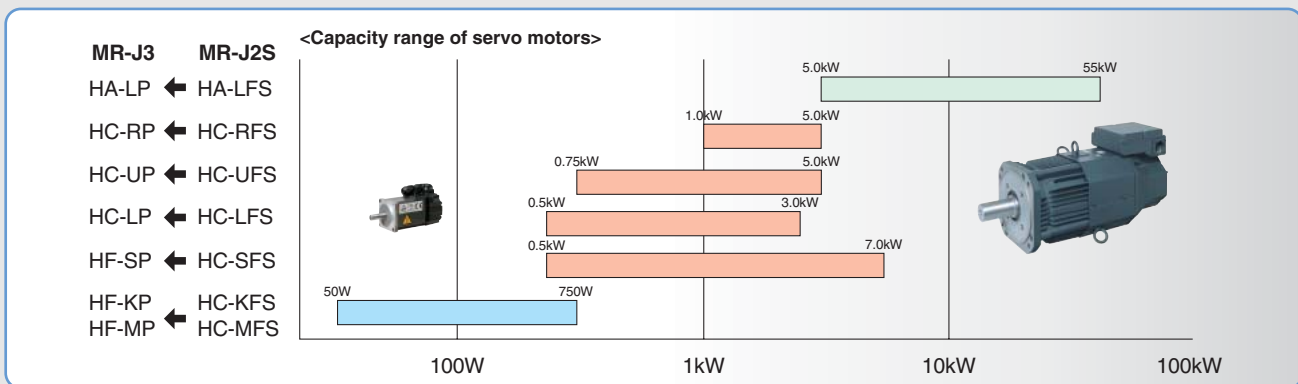

### ■ Compatible with the various power voltage

- 100VAC, 200VAC, 400VAC class servo amplifiers are available.

## Able to realize high speed with high accuracy

### ■ Tact time improved with high-speed positioning

- High-speed, high-torque motor HF series  
\*Patent pending

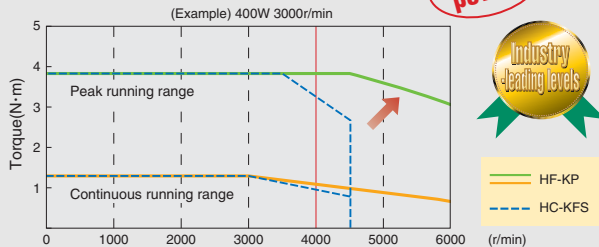

- The high speed motors (6000r/min) and high speed frequency response amplifiers (900Hz) shorten positioning times.

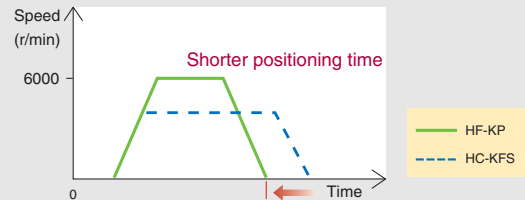

- Maximum speed has been increased to 6000r/min for the HF-KP/HF-MP series, and 3000r/min for the HF-SP□2 series.

### ■ Machine performance improved with highly accurate operation

- A high-resolution encoder 262144p/rev (18-bit) is mounted as standard to realize stability even at low speeds.
- Fluctuations in motor torque were reduced by decreasing the cogging torque.

<Cogging torque> (Note 1)

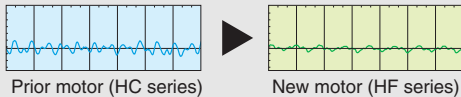

Reduced by 1/2

- The absolute encoder is standard equipment. Home position return at each power on is not necessary if the battery (MR-J3BAT) is mounted on the servo amplifier.

## Compact and flexible

<Servo amplifier>

- Installation area is 40% smaller than prior model (comparison in 400W)

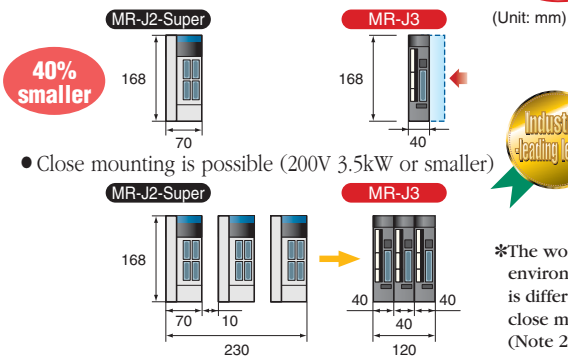

<Servo motor>

- 20% smaller than the prior model (Example: HF-KP/HF-MP series 400W)



<Servo motor>

- The connectors of the HF-SP series are smaller than those of the existing HC-SFS series, so the user's system can be made even more compact.

### ■ Flexible wiring

- Connectors have been adapted for the servo amplifier terminal block thereby reducing the time required for wiring. Refer to the section "Peripheral Equipment" in this catalog for details regarding the connectors. (Connector type terminal blocks are available only for 200V 3.5kW or smaller and 400V 2kW or smaller servo amplifiers.)

- The cable mounting direction is changeable according to the selected cable. (HF-KP/HF-MP series)

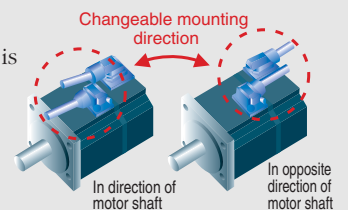

## Environmental safety

### ■ Improved environmental safety

IP65 is standard for the HF-KP/HF-MP/HC-LP/HC-RP/HC-UP servo motor series (excluding the shaft-through portion). (Note 3)

IP67 is standard for the HF-SP servo motor series (excluding the shaft-through portion).



## Compatible with global standards

### ■ Conformity to EN, UL and cUL standards

MELSERVO-J3 conforms to global standards.

\* This product is not subject to China Compulsory Certification (CCC).



Notes: 1. This data is for 750W.

2. Refer to the sections "Amplifier Specifications" and "Cautions Concerning Use" in this catalog for details.

3. Use IP65 rated cables when using the motor in an IP65 environment.



## Advanced and evolving tuning functions

### ■ Easy tuning - Gain adjustment is not necessary -

Ever-evolving Real time Auto-tuning



#### Detailed setting of the response value now possible!

With Mitsubishi's original model adaptive control and the ever-evolving auto-tuning function, tuning can be completed just by changing the response setting value!!

### ■ Precise tuning

#### • To suppress vibration at the end of an arm or to reduce residual vibration in a machine

##### Advanced Vibration Control

\*Patent pending



#### Easily eliminates vibration!

The auto-tuning suppresses vibrations automatically. (Up to 100Hz)

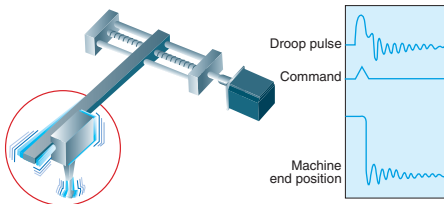

Tuning ON

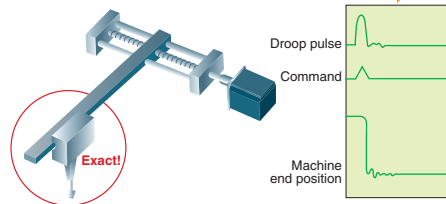

#### • To suppress drive shaft vibrations such as in a ball screw

##### Adaptive Filter II

\*Patent pending



The optimum "machine resonance suppression filter" is automatically set to suppress resonance without even measuring the machine system's (drive shaft) frequency characteristics. The adaptive frequency range has been increased compared to the prior models, so resonance at the drive shaft can also be suppressed. Approximately 100Hz to 2.25kHz (Machine resonance filter: up to 4.5kHz)

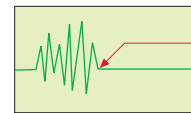
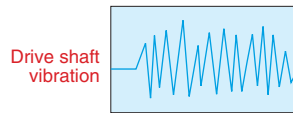

#### • To improve the synchronization accuracy of printing machines and packaging machines, etc.

##### Robust Disturbance Compensation Function



The response to a disturbance element can be increased, independently of other control loop gains, thus making it possible to suppress the disturbance and still maintain stable operations.

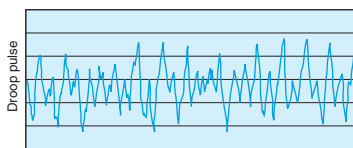

Robust disturbance compensation function ON

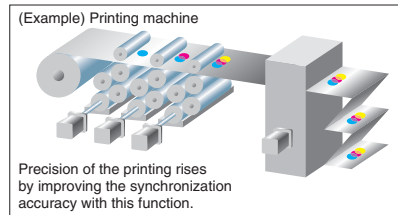
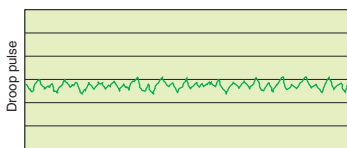

## MR Configurator (Setup software)

### ■ Simple setup and tuning support tools

#### • Simple setup

The new "Parameter setting" window makes setup even easier!

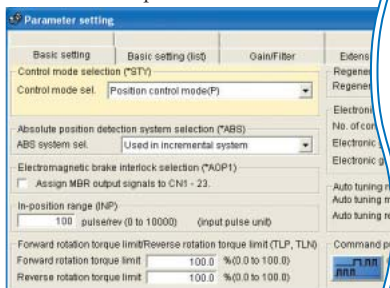

#### • To view motor status

##### Monitor and diagnostic functions



• USB interface enables high-speed sampling and long-term waveform measurement.

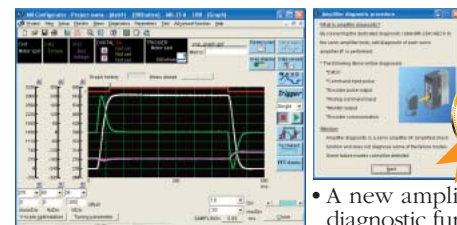

• One analog channel has been added to the graph function (total: 3ch).

• A new amplifier diagnostic function has been added.







# Model Configuration

■ For servo amplifier 100VAC/200VAC/400VAC

## MR-J3-10 A 1-

Mitsubishi general-purpose  
AC servo amplifier  
MELSERVO-J3 Series

Symbol	Special specifications
U004	1-phase 200 to 240VAC (Note 1)
RJ040	Compatible with high resolution analog speed torque command (Note 2)
RJ004	Compatible with linear servo (Note 3)
RJ006	Compatible with fully closed loop control (Note 3)
RU006	Compatible with fully closed loop control, without a dynamic brake (Note 3)
RZ006	Compatible with fully closed loop control, without an enclosed regenerative resistor (Note 3, 4)
KE	Compatible with 4Mpps command (Note 5)
ED	Without a dynamic brake (Note 6)
PX	Without an enclosed regenerative resistor (Note 4)

Notes: 1. Available in 750W or smaller servo amplifier  
 2. Available in MR-J3-□A□ only. Extension IO unit, MR-J3-D01, is required.  
 3. Available in MR-J3-□B□ only.  
 4. Available in 11kW to 22kW servo amplifier. A regenerative resistor (standard accessory) is not enclosed.  
 5. Available in MR-J3-□A(1) only  
 6. Dynamic brake does not work at alarm occurrence or power failure. Take measures to ensure safety.

Symbol	Power supply
None	3-phase 200VAC or 1-phase 200VAC (Note 1)
1	1-phase 100VAC (Note 2)
4	3-phase 400VAC (Note 3)

Notes: 1. The 1-phase 200VAC is available only for the MR-J3-70□ or smaller servo amplifiers.  
 2. Only for the MR-J3-40□1 or smaller servo amplifiers.  
 3. Only for 0.6kW and 1.0kW or larger servo amplifiers.

**A: General-purpose interface**  
**B: SSCNET III compatible**  
**T: CC-Link compatible built-in positioning function**

### List of compatible motors

Symbol	200VAC class						400VAC class		
	HF-KP	HF-MP	HF-SP	HC-LP	HC-RP	HC-UP	HA-LP	HF-SP	HA-LP
10	053, 13	053, 13	—	—	—	—	—	—	—
20	23	23	—	—	—	—	—	—	—
40	43	43	—	—	—	—	—	—	—
60	—	—	51, 52	52	—	—	—	524	—
70	73	73	—	—	—	72	—	—	—
100	—	—	81, 102	102	—	—	—	1024	—
200	—	—	121, 201, 152, 202	152	103, 153	152	—	1524, 2024	—
350	—	—	301, 352	202	203	202	—	3524	—
500	—	—	421, 502	302	353, 503	352, 502	502	5024	—
700	—	—	702	—	—	—	601, 701M, 702	7024	6014, 701M4
11K	—	—	—	—	—	—	801, 12K1, 11K1M, 11K2	—	8014, 12K14, 11K1M4, 11K24
15K	—	—	—	—	—	—	15K1, 15K1M, 15K2	—	15K14, 15K1M4, 15K24
22K	—	—	—	—	—	—	20K1, 25K1, 22K1M, 22K2	—	20K14, 22K1M4, 22K24

\* The amplifiers above conform to EN, CL and cUL standards.

# Model Configuration

## ■ For drive unit 200VAC/400VAC

**MR-J3-DU** **30K** **A**

Mitsubishi general-purpose  
AC servo amplifier  
MELSERVO-J3 Series

**A: General-purpose interface**  
**B: SSCNET III compatible**

Symbol	Power supply
None	3-phase 200VAC
4	3-phase 400VAC

### List of compatible motors

Symbol	HA-LP
30K	30K1, 30K1M, 30K2, 25K14, 30K14, 30K1M4, 30K24
37K	37K1, 37K1M, 37K2, 37K14, 37K1M4, 37K24
45K	45K1M4, 45K24
55K	50K1M4, 55K24

The converter unit  
(MR-J3-CR55K(4))  
is required for the  
drive unit.

## ■ For converter unit 200VAC/400VAC

**MR-J3-CR** **55K**

Mitsubishi general-purpose  
AC servo amplifier  
MELSERVO-J3 Series

Rated output: 55kW

Symbol	Power supply
None	3-phase 200VAC
4	3-phase 400VAC

\* The drive unit and the converter unit conform to EN, UL and cUL standards.

## ■ For servo motor 100V/200V

# HF-KP 05 3 B

Symbol	Motor series
HF-KP	Low inertia, small capacity
HF-MP	Ultra-low inertia, small capacity
HF-SP	Medium inertia, medium capacity
HC-LP	Low inertia, medium capacity
HC-RP	Ultra-low inertia, medium capacity
HC-UP	Flat type, medium capacity
HA-LP	Low inertia, medium-large capacity

Symbol	Oil seal
None	None (Note1)
J	Installed (Note2, 3)

Notes: 1. An oil seal is attached for the HC-LP, HC-RP, HC-UP and HA-LP series as standard.  
 2. Dimensions for the HF-KP/HF-MP series with an oil seal are different from those for the standard model. Contact Mitsubishi for details.  
 3. For the HF-KP/HF-MP series, the servo motors with an oil seal are available for 0.1kW or larger.

Symbol	Shaft end
None	Standard (Straight shaft)
K	Key way or with key (Note)
D	D-cut (Note)

Note: Refer to the section "Special shaft end specifications" in this catalog for the available models and detailed specifications.

Symbol	Electromagnetic brake
None	None
B	Installed

Note: Refer to the section "Electromagnetic brake specifications" in this catalog for the available models and detailed specifications.

Symbol	Rated speed (r/min)
1	1000
1M	1500
2	2000
3	3000

Symbol	Rated output (kW)
05	0.05
1 to 8	0.1 to 0.85
10 to 80	1.0 to 8.0
11K to 37K	11 to 37

## ■ For servo motor 400V

# HF-SP 5 2 4 B

Symbol	Motor series
HF-SP	Medium inertia, medium capacity
HA-LP	Low inertia, medium-large capacity

400VAC class

Symbol	Shaft end
None	Standard (Straight shaft)
K	Key way (Note)

Note: Refer to the section "Special shaft end specifications" in this catalog for the available models and detailed specifications.

Symbol	Rated output (kW)
5	0.5
10 to 80	1.0 to 8.0
11K to 55K	11 to 55

Symbol	Rated speed (r/min)
1	1000
1M	1500
2	2000

Symbol	Electromagnetic brake
None	None
B	Installed

Note: Refer to the section "Electromagnetic brake specifications" in this catalog for the available models and detailed specifications.

\* The servo motors above conform to EN, CL, cUL standards. However, some of the HF-SP and HA-LP servo motor series are under application for these standards. Contact Mitsubishi for more details.

# Motor Specifications and Characteristics



## HF-KP series servo motor specifications

Servo motor series		HF-KP series (Low inertia, small capacity)					
Servo motor model HF-KP		053(B)	13(B)	23(B)	43(B)	73(B)	
Servo amplifier model MR-J3-		10A(1)/B(1)(-RJ006)/T(1)		20A(1)/B(1)(-RJ006)/T(1)	40A(1)/B(1)(-RJ006)/T(1)	70A/B(-RJ006)/T	
Servo motor	Power facility capacity (Note 1) (kVA)	0.3	0.3	0.5	0.9	1.3	
	Continuous running duty	Rated output (W)	50	100	200	400	750
		Rated torque (N·m [oz·in])	0.16 (22.7)	0.32 (45.3)	0.64 (90.6)	1.3 (184)	2.4 (340)
	Maximum torque (N·m [oz·in])	0.48 (68.0)	0.95 (135)	1.9 (269)	3.8 (538)	7.2 (1020)	
	Rated speed (r/min)	3000					
	Maximum speed (r/min)	6000					
	Permissible instantaneous speed (r/min)	6900					
	Power rate at continuous rated torque (kW/s)	4.87	11.5	16.9	38.6	39.9	
	Rated current (A)	0.9	0.8	1.4	2.7	5.2	
	Maximum current (A)	2.7	2.4	4.2	8.1	15.6	
	Regenerative braking frequency (times/min) (Note 2)	(Note 2-1)	(Note 2-2)	448	249	140	
	Moment of inertia J ( $\times 10^{-4}$ kg·m <sup>2</sup> ) [J (oz·in <sup>2</sup> )]	Standard	0.052 (0.284)	0.088 (0.481)	0.24 (1.31)	0.42 (2.30)	1.43 (7.82)
		With electromagnetic brake	0.054 (0.295)	0.090 (0.492)	0.31 (1.69)	0.50 (2.73)	1.63 (8.91)
	Recommended load/motor inertia moment ratio (Note 3)	15 times maximum		24 times maximum	22 times maximum	15 times maximum	
	Speed/position detector	18-bit encoder (Resolution per encoder/servo motor rotation: 262144 p/rev)					
	Attachments	—		— (Motors with an oil seal are available (HF-KP□J))			
Insulation class	Class B						
Structure	Totally enclosed non ventilated (protection level: IP65) (Note 4)						
Environment	Ambient temperature	0 to 40°C (32 to 104°F) (non freezing), storage: -15 to 70°C (5 to 158°F) (non freezing)					
	Ambient humidity	80% RH maximum (non condensing), storage: 90% RH maximum (non condensing)					
	Atmosphere	Indoors (no direct sunlight); no corrosive gas, inflammable gas, oil mist or dust					
	Elevation	1000m or less above sea level					
	Vibration (Note 5)	X: 49m/s <sup>2</sup> Y: 49m/s <sup>2</sup>					
Mass (kg [lb])	Standard	0.35 (0.78)	0.56 (1.3)	0.94 (2.1)	1.5 (3.3)	2.9 (6.4)	
	With electromagnetic brake	0.65 (1.5)	0.86 (1.9)	1.6 (3.6)	2.1 (4.7)	3.9 (8.6)	

- Notes: 1. The power facility capacity varies depending on the power supply's impedance.  
 2. The regenerative braking frequency shows the permissible frequency when the motor, without a load and the optional regeneration unit, decelerates from the rated speed to a stop. When a load is connected; however, the value will be the table value/(m+1), where m=the load inertia moment/the motor inertia moment. When the operating speed exceeds the rated speed, the regenerative braking frequency is inversely proportional to the square of (operating speed/rated speed). If the operating speed changes frequently or when the regeneration is constant (as with vertical feeds), find the regenerative heating value (W) in operation. Provisions must be made to keep this heating value below the tolerable regenerative power (W). Optimal regenerative resistor varies for each system. Select the most suitable regenerative resistor by using the Servo Support software. Refer to the section "Options ● Optional regeneration unit" in this catalog for details on the tolerable regenerative power (W).  
 2-1. When the motor decelerates to a stop from the rated speed, the regenerative frequency will not be limited if the effective torque is within the rated torque range. When the motor decelerates to a stop from the maximum speed, the regenerative frequency will not be limited if the load inertia moment is 8 times or less and the effective torque is within the rated torque range.  
 2-2. When the motor decelerates to a stop from the rated speed, the regenerative frequency will not be limited if the effective torque is within the rated torque range. When the motor decelerates to a stop from the maximum speed, the regenerative frequency will not be limited if the load inertia moment is 4 times or less and the effective torque is within the rated torque range.  
 3. Contact Mitsubishi if the load/motor of inertia moment ratio exceeds the value in the table.  
 4. The shaft-through portion is excluded.  
 5. The vibration direction is shown in the right-side diagram. The numeric value indicates the maximum value of the component (commonly the bracket in the opposite direction of the motor shaft). Fretting of the bearing occurs easily when the motor stops, so maintain vibration to approximately one-half of the allowable value.



## HF-KP series servo motor torque characteristics

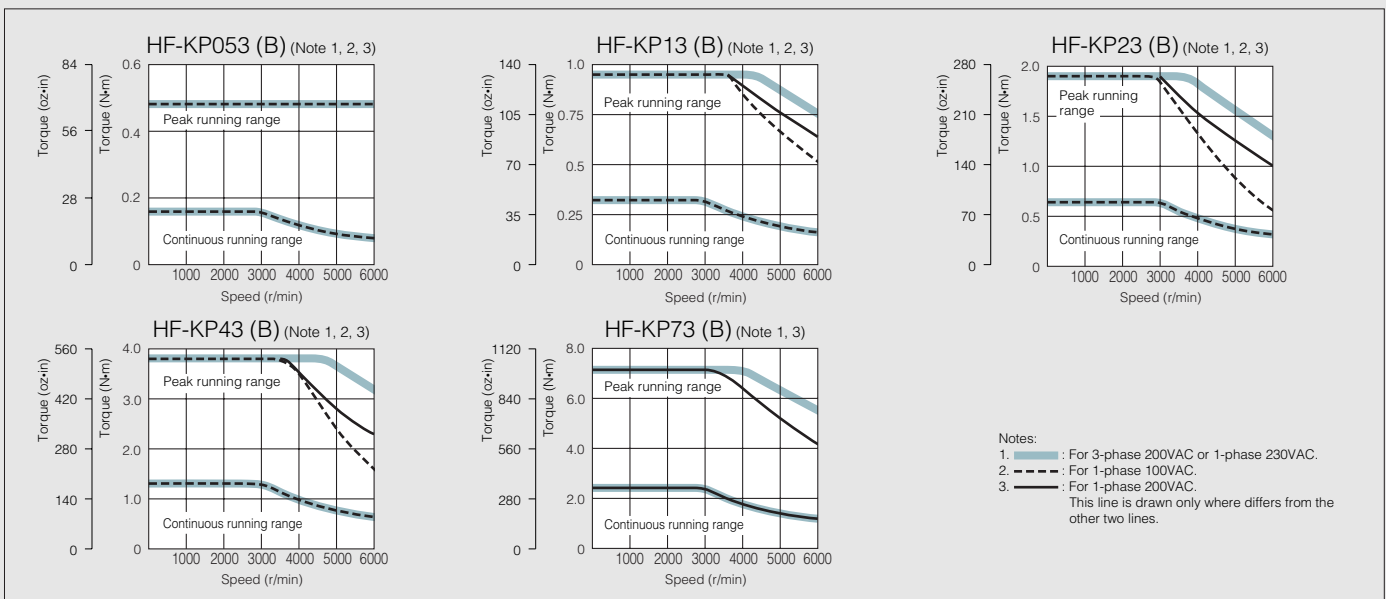

# Motor Specifications and Characteristics



## HF-MP series servo motor specifications

Servo motor series		HF-MP series (Ultra-low inertia, small capacity)					
Servo motor model HF-MP		053(B)	13(B)	23(B)	43(B)	73(B)	
Servo amplifier model (Note 6) MR-J3-		10A(1)/B(1)(-RJ006)/T(1)		20A(1)/B(1)(-RJ006)/T(1)	40A(1)/B(1)(-RJ006)/T(1)	70A/B(-RJ006)/T	
Servo motor	Power facility capacity (Note 1) (kVA)	0.3	0.3	0.5	0.9	1.3	
	Continuous running duty	Rated output (W)	50	100	200	400	750
		Rated torque (N·m [oz·in])	0.16 (22.7)	0.32 (45.3)	0.64 (90.6)	1.3 (184)	2.4 (340)
	Maximum torque (N·m [oz·in])	0.48 (68.0)	0.95 (135)	1.9 (269)	3.8 (538)	7.2 (1020)	
	Rated speed (r/min)	3000					
	Maximum speed (r/min)	6000					
	Permissible instantaneous speed (r/min)	6900					
	Power rate at continuous rated torque (kW/s)	13.3	31.7	46.1	111.6	95.5	
	Rated current (A)	1.1	0.9	1.6	2.7	5.6	
	Maximum current (A)	3.2	2.8	5.0	8.6	16.7	
	Regenerative braking frequency (times/min) (Note 2)	(Note 2-1)	(Note 2-2)	1570	920	420	
	Moment of inertia J ( $\times 10^{-4}$ kg·m <sup>2</sup> ) [J (oz·in <sup>2</sup> )]	Standard	0.019 (0.104)	0.032 (0.175)	0.088 (0.481)	0.15 (0.820)	0.60 (3.28)
		With electromagnetic brake	0.025 (0.137)	0.039 (0.213)	0.12 (0.656)	0.18 (0.984)	0.70 (3.83)
	Recommended load/motor inertia moment ratio	30 times the servo motor's inertia moment maximum (Note 3)					
	Speed/position detector	18-bit encoder (Resolution per encoder/servo motor rotation: 262144 p/rev)					
	Attachments	—	— (Motors with an oil seal are available (HF-MP□J))				
Insulation class	Class B						
Structure	Totally enclosed non ventilated (protection level: IP65) (Note 4)						
Environment	Ambient temperature	0 to 40°C (32 to 104°F) (non freezing), storage: -15 to 70°C (5 to 158°F) (non freezing)					
	Ambient humidity	80% RH maximum (non condensing), storage: 90% RH maximum (non condensing)					
	Atmosphere	Indoors (no direct sunlight); no corrosive gas, inflammable gas, oil mist or dust					
	Elevation	1000m or less above sea level					
	Vibration (Note 5)	X: 49m/s <sup>2</sup> Y: 49m/s <sup>2</sup>					
Mass (kg [lb])	Standard	0.35 (0.78)	0.56 (1.3)	0.94 (2.1)	1.5 (3.3)	2.9 (6.4)	
	With electromagnetic brake	0.65 (1.5)	0.86 (1.9)	1.6 (3.6)	2.1 (4.7)	3.9 (8.6)	

Notes: 1. The power facility capacity varies depending on the power supply's impedance.

2. The regenerative braking frequency shows the permissible frequency when the motor, without a load and the optional regeneration unit, decelerates from the rated speed to a stop. When a load is connected, however, the value will be the table value/(m+1), where m=the load inertia moment/the motor inertia moment. When the operating speed exceeds the rated speed, the regenerative braking frequency is inversely proportional to the square of (operating speed/rated speed). If the operating speed changes frequently or when the regeneration is constant (as with vertical feeds), find the regenerative heating value (W) in operation. Provisions must be made to keep this heating value below the tolerable regenerative power (W). Optimal regenerative resistor varies for each system. Select the most suitable regenerative resistor by using the Servo Support software. Refer to the section "Options ● Optional regeneration unit" in this catalog for details on the tolerable regenerative power (W).

2-1. When the motor decelerates to a stop from the rated speed, the regenerative frequency will not be limited if the effective torque is within the rated torque range. When the motor decelerates to a stop from the maximum speed, the regenerative frequency will not be limited if the load inertia moment is 26 times or less and the effective torque is within the rated torque range.

2-2. When the motor decelerates to a stop from the rated speed, the regenerative frequency will not be limited if the effective torque is within the rated torque range. When the motor decelerates to a stop from the maximum speed, the regenerative frequency will not be limited if the load inertia moment is 15 times or less and the effective torque is within the rated torque range.

3. Contact Mitsubishi if the load/motor of inertia moment ratio exceeds the value in the table.

4. The shaft-through portion is excluded.

5. The vibration direction is shown in the right-side diagram. The numeric value indicates the maximum value of the component (commonly the bracket in the opposite direction of the motor shaft). Fretting of the bearing occurs easily when the motor stops, so maintain vibration to approximately one-half of the allowable value.

6. When using MR-J3-□A(1) with these motors, the servo amplifier software version must be A4 or above.



## HF-MP series servo motor torque characteristics

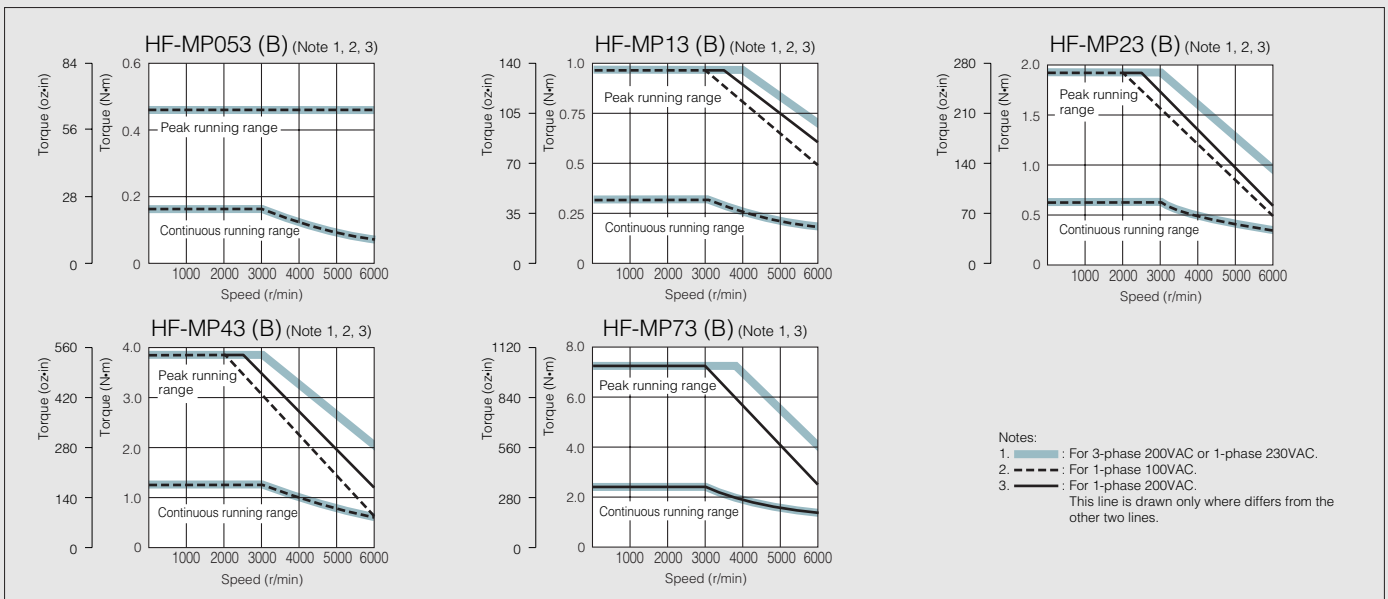

# Motor Specifications and Characteristics



## HC-LP series servo motor specifications

Servo motor series		HC-LP series (Low inertia, medium capacity)					
Servo motor model HC-LP		52(B)	102(B)	152(B)	202(B)	302(B)	
Servo amplifier model MR-J3-		60A/B(-RJ006)/T	100A/B(-RJ006)/T	200A/B(-RJ006)/T	350A/B(-RJ006)/T	500A/B(-RJ006)/T	
Servo motor	Power facility capacity (Note 1) (kVA)	1.0	1.7	2.5	3.5	4.8	
	Continuous running duty	Rated output (kW)	0.5	1.0	1.5	2.0	3.0
		Rated torque (N·m [oz·in])	2.39 (338)	4.78 (677)	7.16 (1010)	9.55 (1350)	14.3 (2020)
	Maximum torque (N·m [oz·in])	7.16 (1010)	14.4 (2040)	21.6 (3060)	28.5 (4040)	42.9 (6070)	
	Rated speed (r/min)	2000					
	Maximum speed (r/min)	3000					
	Permissible instantaneous speed (r/min)	3450					
	Power rate at continuous rated torque (kW/s)	18.4	49.3	79.8	41.5	56.8	
	Rated current (A)	3.2	5.9	9.9	14	23	
	Maximum current (A)	9.6	18	30	42	69	
	Regenerative braking frequency (times/min) (Note 2)	115	160	425	120	70	
	Moment of inertia J ( $\times 10^{-4}$ kg·m <sup>2</sup> ) [J (oz·in <sup>2</sup> )]	Standard	3.10 (16.9)	4.62 (25.3)	6.42 (35.1)	22.0 (120)	36.0 (197)
		With electromagnetic brake	5.20 (28.4)	6.72 (36.7)	8.52 (46.6)	32.0 (175)	46.0 (252)
	Recommended load/motor inertia moment ratio	10 times the servo motor's inertia moment maximum (Note 3)					
	Speed/position detector	18-bit encoder (Resolution per encoder/servo motor rotation: 262144 p/rev)					
	Attachments	Oil seal					
	Insulation class	Class F					
Structure	Totally enclosed non ventilated (protection level: IP65) (Note 4)						
Environment	Ambient temperature	0 to 40°C (32 to 104°F) (non freezing), storage: -15 to 70°C (5 to 158°F) (non freezing)					
	Ambient humidity	80% RH maximum (non condensing), storage: 90% RH maximum (non condensing)					
	Atmosphere	Indoors (no direct sunlight); no corrosive gas, inflammable gas, oil mist or dust					
	Elevation	1000m or less above sea level					
	Vibration (Note 5)	X: 9.8m/s <sup>2</sup> Y: 24.5m/s <sup>2</sup>			X: 19.6m/s <sup>2</sup> Y: 49m/s <sup>2</sup>		
Mass (kg [lb])	Standard	6.5 (15)	8.0 (18)	10 (22)	21 (47)	28 (62)	
	With electromagnetic brake	9.0 (20)	11 (25)	13 (29)	27 (60)	34 (75)	

- Notes: 1. The power facility capacity varies depending on the power supply's impedance.  
 2. The regenerative braking frequency shows the permissible frequency when the motor, without a load and the optional regeneration unit, decelerates from the rated speed to a stop. When a load is connected; however, the value will be the table value/(m+1), where m=the load inertia moment/the motor inertia moment. When the operating speed exceeds the rated speed, the regenerative braking frequency is inversely proportional to the square of (operating speed/rated speed). If the operating speed changes frequently or when the regeneration is constant (as with vertical feeds), find the regenerative heating value (W) in operation. Provisions must be made to keep this heating value below the tolerable regenerative power (W). Optimal regenerative resistor varies for each system. Select the most suitable regenerative resistor by using the Servo Support software. Refer to the section "Options ● Optional regeneration unit" in this catalog for details on the tolerable regenerative power (W).  
 3. Contact Mitsubishi if the load/motor of inertia moment ratio exceeds the value in the table.  
 4. The shaft-through portion is excluded.  
 5. The vibration direction is shown in the right-side diagram. The numeric value indicates the maximum value of the component (commonly the bracket in the opposite direction of the motor shaft). Fretting of the bearing occurs easily when the motor stops, so maintain vibration to approximately one-half of the allowable value.



## HC-LP series servo motor torque characteristics

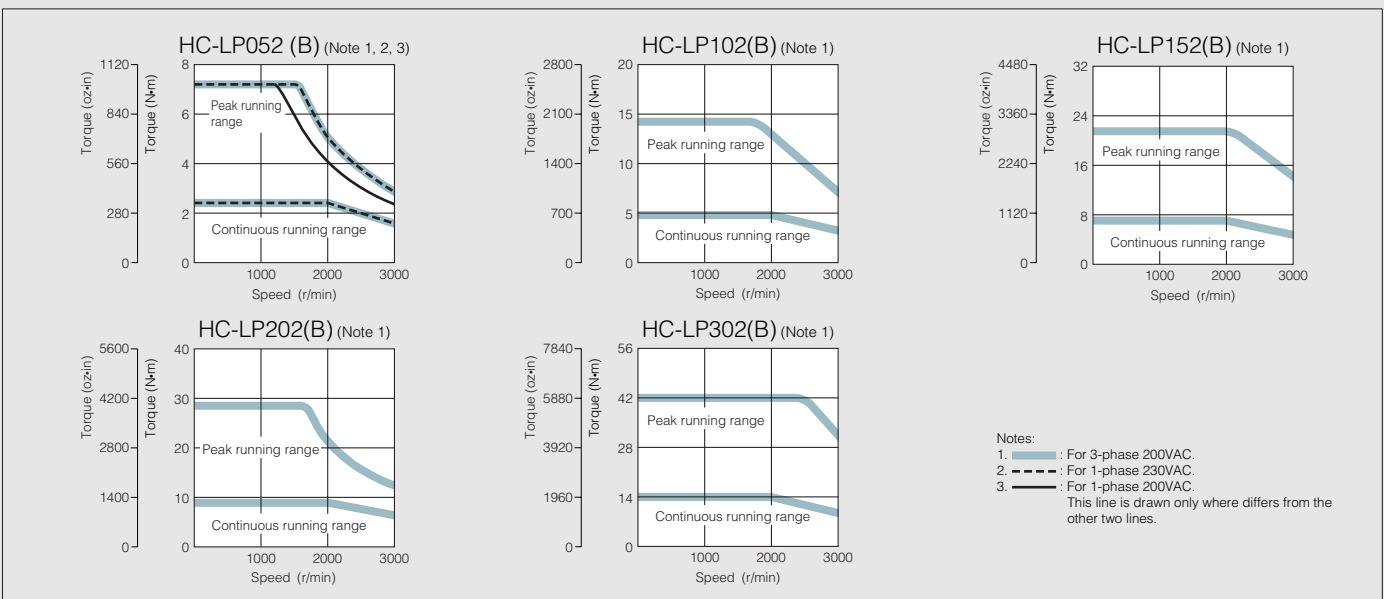

# Motor Specifications and Characteristics



## HC-RP series servo motor specifications

Servo motor series		HC-RP series (Ultra low inertia, medium capacity)					
Servo motor model HC-RP		103(B)	153(B)	203(B)	353(B)	503(B)	
Servo amplifier model MR-J3-		200A/B(-RJ006)/T		350A/B(-RJ006)/T	500A/B(-RJ006)/T		
Servo motor	Power facility capacity (Note 1) (kVA)	1.7	2.5	3.5	5.5	7.5	
	Continuous running duty	Rated output (kW)	1.0	1.5	2.0	3.5	5.0
		Rated torque (N·m [oz·in])	3.18 (450)	4.78 (677)	6.37 (902)	11.1 (1570)	15.9 (2250)
	Maximum torque (N·m [oz·in])	7.95 (1130)	11.9 (1690)	15.9 (2250)	27.9 (3950)	39.7 (5620)	
	Rated speed (r/min)	3000					
	Maximum speed (r/min)	4500					
	Permissible instantaneous speed (r/min)	5175					
	Power rate at continuous rated torque (kW/s)	67.4	120	176	150	211	
	Rated current (A)	6.1	8.8	14	23	28	
	Maximum current (A)	18	23	37	58	70	
	Regenerative braking frequency (times/min) (Note 2)	1090	860	710	174	125	
	Moment of inertia J ( $\times 10^{-4}$ kg·m <sup>2</sup> ) [J (oz·in <sup>2</sup> )]	Standard	1.50 (8.20)	1.90 (10.4)	2.30 (12.6)	8.30 (45.4)	12.0 (65.6)
		With electromagnetic brake	1.85 (10.1)	2.25 (12.3)	2.65 (14.5)	11.8 (64.5)	15.5 (84.7)
	Recommended load/motor inertia moment ratio	5 times the servo motor's inertia moment maximum (Note 3)					
	Speed/position detector	18-bit encoder (Resolution per encoder/servo motor rotation: 262144 p/rev)					
	Attachments	Oil seal					
	Insulation class	Class F					
	Structure	Totally enclosed non ventilated (protection level: IP65) (Note 4)					
	Environment	Ambient temperature	0 to 40°C (32 to 104°F) (non freezing), storage: -15 to 70°C (5 to 158°F) (non freezing)				
		Ambient humidity	80% RH maximum (non condensing), storage: 90% RH maximum (non condensing)				
Atmosphere		Indoors (no direct sunlight); no corrosive gas, inflammable gas, oil mist or dust					
Elevation		1000m or less above sea level					
Vibration (Note 5)		X: 24.5m/s <sup>2</sup> Y: 24.5m/s <sup>2</sup>					
Mass (kg [lb])	Standard	3.9 (8.6)	5.0 (11)	6.2 (14)	12 (27)	17 (38)	
	With electromagnetic brake	6.0 (14)	7.0 (16)	8.3 (19)	15 (33)	21 (47)	

- Notes: 1. The power facility capacity varies depending on the power supply's impedance.  
 2. The regenerative braking frequency shows the permissible frequency when the motor, without a load and the optional regeneration unit, decelerates from the rated speed to a stop. When a load is connected, however, the value will be the table value/(m+1), where m=the load inertia moment/the motor inertia moment. When the operating speed exceeds the rated speed, the regenerative braking frequency is inversely proportional to the square of (operating speed/rated speed). If the operating speed changes frequently or when the regeneration is constant (as with vertical feeds), find the regenerative heating value (W) in operation. Provisions must be made to keep this heating value below the tolerable regenerative power (W). Optimal regenerative resistor varies for each system. Select the most suitable regenerative resistor by using the Servo Support software. Refer to the section "Options ● Optional regeneration unit" in this catalog for details on the tolerable regenerative power (W).  
 3. Contact Mitsubishi if the load/motor of inertia moment ratio exceeds the value in the table.  
 4. The shaft-through portion is excluded.  
 5. The vibration direction is shown in the right-side diagram. The numeric value indicates the maximum value of the component (commonly the bracket in the opposite direction of the motor shaft). Fretting of the bearing occurs easily when the motor stops, so maintain vibration to approximately one-half of the allowable value.



## HC-RP series servo motor torque characteristics

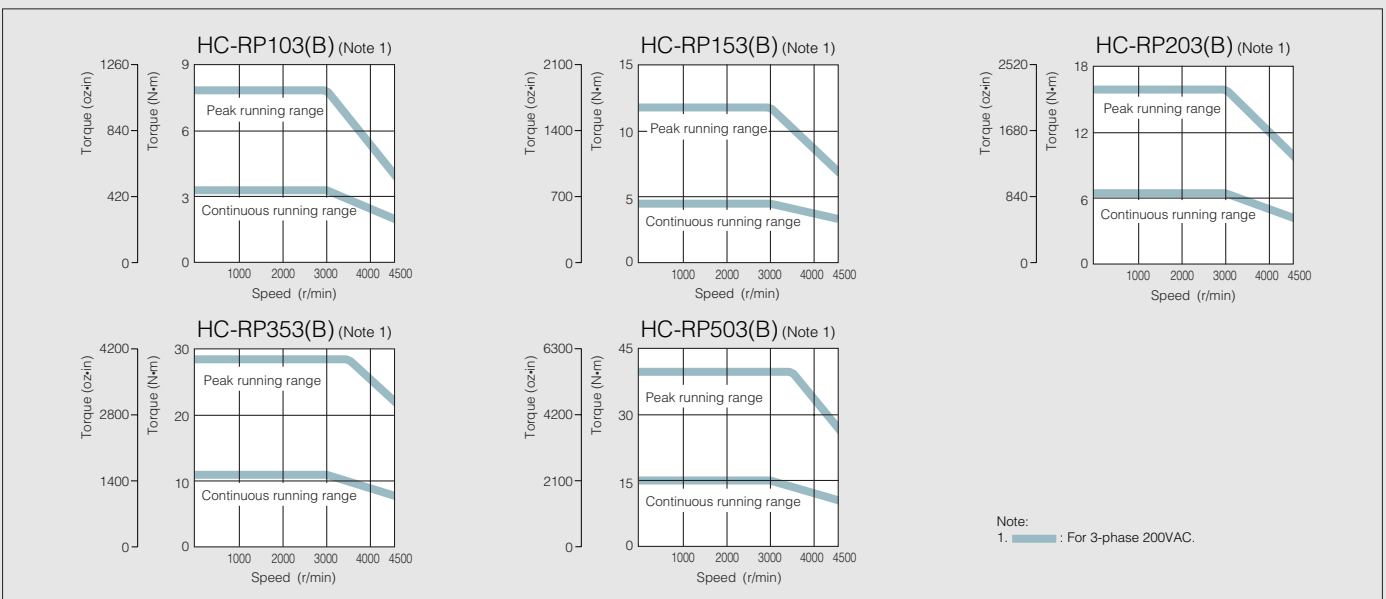

# Motor Specifications and Characteristics



## HC-UP series servo motor specifications

Servo motor series		HC-UP series (Flat type, medium capacity)					
Servo motor model HC-UP		72(B)	152(B)	202(B)	352(B)	502(B)	
Servo amplifier model MR-J3-		70A/B(-RJ006)/T	200A/B(-RJ006)/T	350A/B(-RJ006)/T	500A/B(-RJ006)/T		
Servo motor	Power facility capacity (Note 1) (kVA)	1.3	2.5	3.5	5.5	7.5	
	Continuous running duty	Rated output (kW)	0.75	1.5	2.0	3.5	5.0
		Rated torque (N·m [oz·in])	3.58 (507)	7.16 (1010)	9.55 (1350)	16.7 (2360)	23.9 (3380)
	Maximum torque (N·m [oz·in])	10.7 (1520)	21.6 (3060)	28.5 (4040)	50.1 (7090)	71.6 (10100)	
	Rated speed (r/min)	2000					
	Maximum speed (r/min)	3000			2500		
	Permissible instantaneous speed (r/min)	3450			2875		
	Power rate at continuous rated torque (kW/s)	12.3	23.2	23.9	36.5	49.6	
	Rated current (A)	5.4	9.7	14	23	28	
	Maximum current (A)	16	29	42	69	84	
	Regenerative braking frequency (times/min) (Note 2)	53	124	68	44	31	
	Moment of inertia J ( $\times 10^{-4}$ kg·m <sup>2</sup> ) [J (oz·in <sup>2</sup> )]	Standard	10.4 (56.9)	22.1 (121)	38.2 (209)	76.5 (418)	115 (629)
		With electromagnetic brake	12.5 (68.3)	24.2 (132)	46.8 (256)	85.1 (465)	124 (678)
	Recommended load/motor inertia moment ratio	15 times the servo motor's inertia moment maximum (Note 3)					
	Speed/position detector	18-bit encoder (Resolution per encoder/servo motor rotation: 262144 p/rev)					
	Attachments	Oil seal					
Insulation class	Class F						
Structure	Totally enclosed non ventilated (protection level: IP65) (Note 4)						
Environment	Ambient temperature	0 to 40°C (32 to 104°F) (non freezing), storage: -15 to 70°C (5 to 158°F) (non freezing)					
	Ambient humidity	80% RH maximum (non condensing), storage: 90% RH maximum (non condensing)					
	Atmosphere	Indoors (no direct sunlight); no corrosive gas, inflammable gas, oil mist or dust					
	Elevation	1000m or less above sea level					
	Vibration (Note 5)	X: 24.5m/s <sup>2</sup> Y: 24.5m/s <sup>2</sup>		X: 24.5m/s <sup>2</sup> Y: 49m/s <sup>2</sup>			
Mass (kg [lb])	Standard	8.0 (18)	11 (25)	16 (36)	20 (44)	24 (53)	
	With electromagnetic brake	10 (22)	13 (29)	22 (49)	26 (58)	30 (67)	

- Notes: 1. The power facility capacity varies depending on the power supply's impedance.  
 2. The regenerative braking frequency shows the permissible frequency when the motor, without a load and the optional regeneration unit, decelerates from the rated speed to a stop. When a load is connected; however, the value will be the table value/(m+1), where m=the load inertia moment/the motor inertia moment. When the operating speed exceeds the rated speed, the regenerative braking frequency is inversely proportional to the square of (operating speed/rated speed). If the operating speed changes frequently or when the regeneration is constant (as with vertical feeds), find the regenerative heating value (W) in operation. Provisions must be made to keep this heating value below the tolerable regenerative power (W). Optimal regenerative resistor varies for each system. Select the most suitable regenerative resistor by using the Servo Support software. Refer to the section "Options ● Optional regeneration unit" in this catalog for details on the tolerable regenerative power (W).  
 3. Contact Mitsubishi if the load/motor of inertia moment ratio exceeds the value in the table.  
 4. The shaft-through portion is excluded.  
 5. The vibration direction is shown in the right-side diagram. The numeric value indicates the maximum value of the component (commonly the bracket in the opposite direction of the motor shaft). Fretting of the bearing occurs easily when the motor stops, so maintain vibration to approximately one-half of the allowable value.



## HC-UP series servo motor torque characteristics

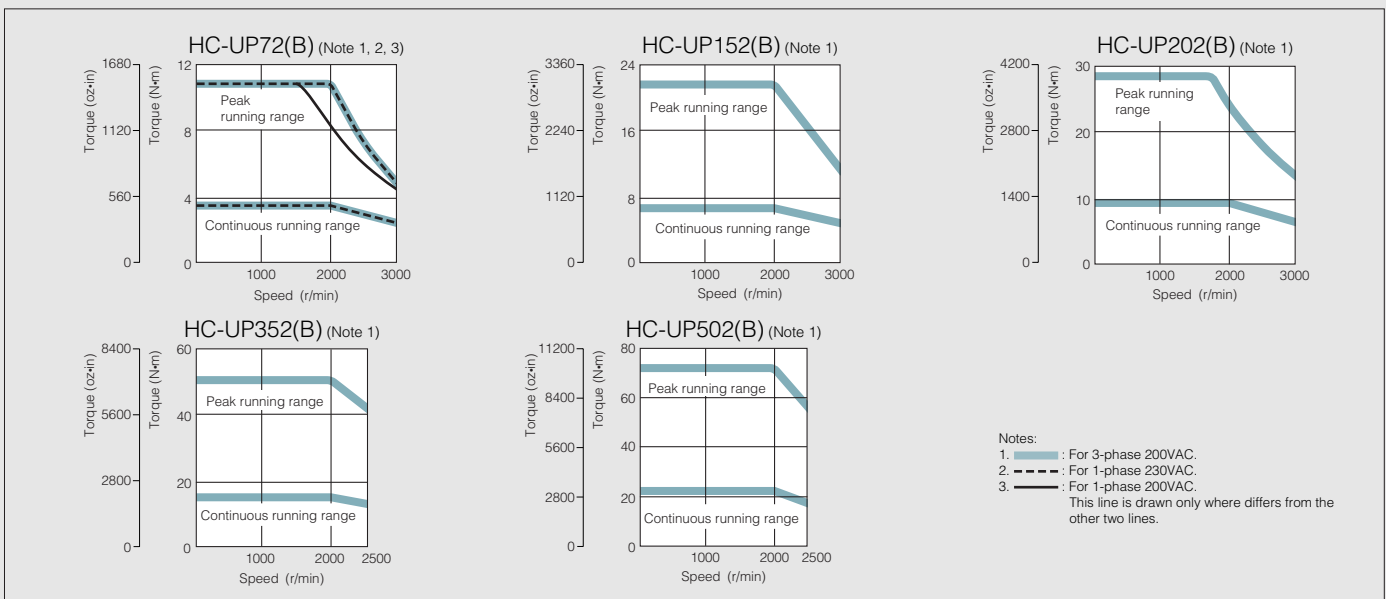



# Motor Specifications and Characteristics



## HF-SP 1000r/min series servo motor specifications

Servo motor series		HF-SP 1000r/min series (Medium inertia, medium capacity)						
Servo motor model HF-SP		51(B)	81(B)	121(B)	201(B)	301(B)	421(B)	
Servo amplifier model MR-J3-		60A/B(-RJ006)/T (Note 6)	100A/B(-RJ006)/T (Note 6)	200A/B(-RJ006)/T (Note 6)		350A/B(-RJ006)/T	500A/B(-RJ006)/T	
Servo motor	Power facility capacity (Note 1) (kVA)	1.0	1.5	2.1	3.5	4.8	6.3	
	Continuous running duty	Rated output (kW)	0.5	0.85	1.2	2.0	3.0	4.2
		Rated torque (N·m [oz·in])	4.77 (675)	8.12 (1150)	11.5 (1630)	19.1 (2700)	28.6 (4050)	40.1 (5680)
	Maximum torque (N·m [oz·in])	14.3 (2020)	24.4 (3460)	34.4 (4870)	57.3 (8110)	85.9 (12200)	120 (17000)	
	Rated speed (r/min)	1000						
	Maximum speed (r/min)	1500						
	Permissible instantaneous speed (r/min)	1725						
	Power rate at continuous rated torque (kW/s)	19.2	37.0	34.3	48.6	84.6	104	
	Rated current (A)	2.9	4.5	6.5	11	16	24	
	Maximum current (A)	8.7	13.5	19.5	33	48	72	
	Regenerative braking frequency (times/min) (Note 2)	36	90	188	105	84	75	
	Moment of inertia J ( $\times 10^{-4}$ kg·m <sup>2</sup> ) [J (oz·in <sup>2</sup> )]	Standard	11.9 (65.1)	17.8 (97.3)	38.3 (209)	75.0 (410)	97.0 (530)	154 (842)
		With electromagnetic brake	14.0 (76.5)	20.0 (109)	47.9 (262)	84.7 (463)	107 (585)	164 (897)
	Recommended load/motor inertia moment ratio	15 times the servo motor's inertia moment maximum (Note 3)						
	Speed/position detector	18-bit encoder (Resolution per encoder/servo motor rotation: 262144 p/rev)						
	Attachments	— (Motors with an oil seal are available (HF-SP□J))						
	Insulation class	Class F						
	Structure	Totally enclosed non ventilated (protection level: IP67) (Note 4)						
	Environment	Ambient temperature	0 to 40°C (32 to 104°F) (non freezing), storage: -15 to 70°C (5 to 158°F) (non freezing)					
		Ambient humidity	80% RH maximum (non condensing), storage: 90% RH maximum (non condensing)					
Atmosphere		Indoors (no direct sunlight); no corrosive gas, inflammable gas, oil mist or dust						
Elevation		1000m or less above sea level						
Mass (kg [lb])	Standard	6.5 (15)	8.3 (19)	12 (27)	19 (42)	22 (49)	32 (71)	
	With electromagnetic brake	8.5 (19)	10.3 (23)	18 (40)	25 (56)	28 (62)	38 (84)	
Vibration (Note 5)		X: 24.5m/s <sup>2</sup> Y: 24.5m/s <sup>2</sup>		X: 24.5m/s <sup>2</sup> Y: 49m/s <sup>2</sup>		X: 24.5m/s <sup>2</sup> Y: 29.4m/s <sup>2</sup>		

- Notes: 1. The power facility capacity varies depending on the power supply's impedance.  
 2. The regenerative braking frequency shows the permissible frequency when the motor, without a load and the optional regeneration unit, decelerates from the rated speed to a stop. When a load is connected; however, the value will be the table value/(m+1), where m=the load inertia moment/the motor inertia moment. When the operating speed exceeds the rated speed, the regenerative braking frequency is inversely proportional to the square of (operating speed/rated speed). If the operating speed changes frequently or when the regeneration is constant (as with vertical feeds), find the regenerative heating value (W) in operation. Provisions must be made to keep this heating value below the tolerable regenerative power (W). Optimal regenerative resistor varies for each system. Select the most suitable regenerative resistor by using the Servo Support software. Refer to the section "Options ● Optional regeneration unit" in this catalog for details on the tolerable regenerative power (W).  
 3. Contact Mitsubishi if the load/motor of inertia moment ratio exceeds the value in the table.  
 4. The shaft-through portion is excluded.  
 5. The vibration direction is shown in the right-side diagram. The numeric value indicates the maximum value of the component (commonly the bracket in the opposite direction of the motor shaft). Fretting of the bearing occurs easily when the motor stops, so maintain vibration to approximately one-half of the allowable value.  
 6. When using MR-J3-□A with these motors, the servo amplifier software version must be A4 or above.



## HF-SP 1000r/min series servo motor torque characteristics

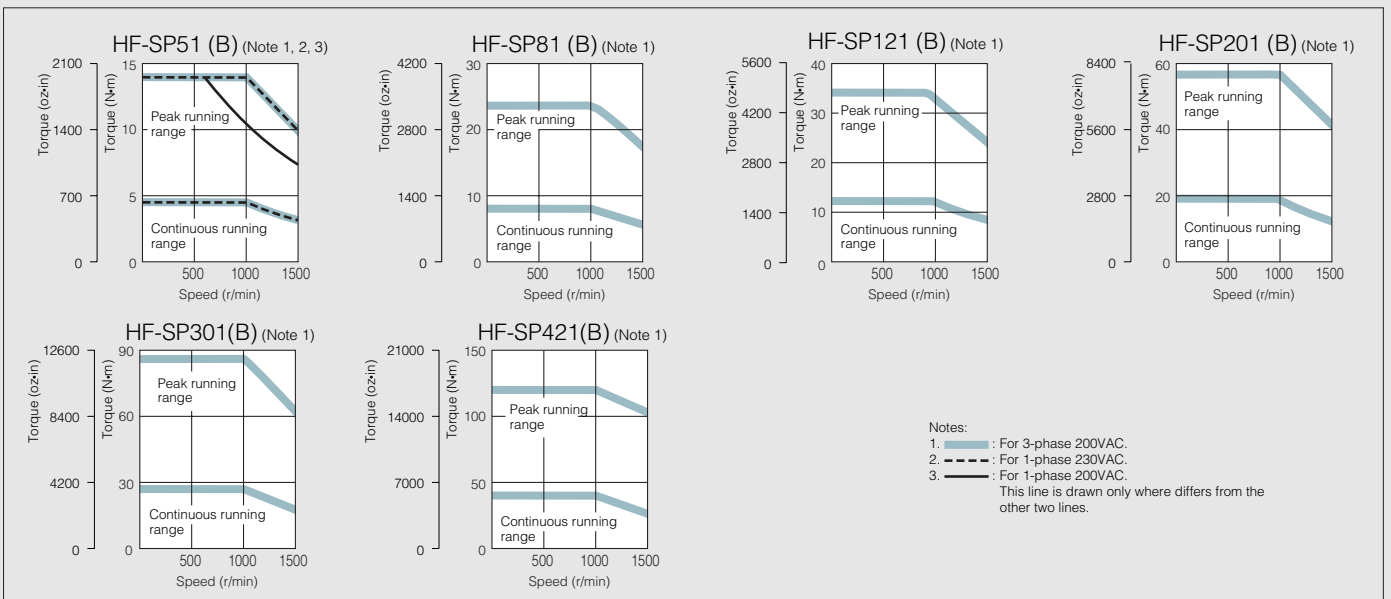

# Motor Specifications and Characteristics



## HF-SP 2000r/min series servo motor specifications (200VAC class)

Servo motor series		HF-SP 2000r/min series (Medium inertia, medium capacity)							
Servo motor model HF-SP		52(B)	102(B)	152(B)	202(B)	352(B)	502(B)	702(B)	
Servo amplifier model MR-J3-		60A/B(-RJ006)/T	100A/B(-RJ006)/T	200A/B(-RJ006)/T		350A/B(-RJ006)/T	500A/B(-RJ006)/T	700A/B(-RJ006)/T	
Servo motor	Power facility capacity (Note 1) (kVA)	1.0	1.7	2.5	3.5	5.5	7.5	10	
	Continuous running duty	Rated output (kW)	0.5	1.0	1.5	2.0	3.5	5.0	7.0
		Rated torque (N·m [oz·in])	2.39 (338)	4.77 (675)	7.16 (1010)	9.55 (1350)	16.7 (2360)	23.9 (3380)	33.4 (4730)
	Maximum torque (N·m [oz·in])	7.16 (1010)	14.3 (2020)	21.5 (3040)	28.6 (4050)	50.1 (7090)	71.6 (10100)	100 (14200)	
	Rated speed (r/min)	2000							
	Maximum speed (r/min)	3000							
	Permissible instantaneous speed (r/min)	3450							
	Power rate at continuous rated torque (kW/s)	9.34	19.2	28.8	23.8	37.2	58.8	72.5	
	Rated current (A)	2.9	5.3	8.0	10	16	24	33	
	Maximum current (A)	8.7	15.9	24	30	48	72	99	
	Regenerative braking frequency (times/min) (Note 2)	60	62	152	71	33	37	31	
	Moment of inertia J ( $\times 10^{-4}$ kg·m <sup>2</sup> ) [J (oz·in <sup>2</sup> )]	Standard	6.1 (33.4)	11.9 (65.1)	17.8 (97.3)	38.3 (209)	75.0 (410)	97.0 (530)	154 (842)
		With electromagnetic brake	8.3 (45.4)	14.0 (76.5)	20.0 (109)	47.9 (262)	84.7 (463)	107 (585)	164 (897)
	Recommended load/motor inertia moment ratio	15 times the servo motor's inertia moment maximum (Note 3)							
	Speed/position detector	18-bit encoder (Resolution per encoder/servo motor rotation: 262144 p/rev)							
Attachments	— (Motors with an oil seal are available (HF-SP□J))								
Insulation class	Class F								
Structure	Totally enclosed non ventilated (protection level: IP67) (Note 4)								
Environment	Ambient temperature	0 to 40°C (32 to 104°F) (non freezing), storage: -15 to 70°C (5 to 158°F) (non freezing)							
	Ambient humidity	80% RH maximum (non condensing), storage: 90% RH maximum (non condensing)							
	Atmosphere	Indoors (no direct sunlight); no corrosive gas, inflammable gas, oil mist or dust							
	Elevation	1000m or less above sea level							
	Vibration (Note 5)	X: 24.5m/s <sup>2</sup> Y: 24.5m/s <sup>2</sup>		X: 24.5m/s <sup>2</sup> Y: 49m/s <sup>2</sup>		X: 24.5m/s <sup>2</sup> Y: 29.4m/s <sup>2</sup>			
Mass (kg [lb])	Standard	4.8 (11)	6.5 (15)	8.3 (19)	12 (27)	19 (42)	22 (49)	32 (71)	
	With electromagnetic brake	6.7 (15)	8.5 (19)	10.3 (23)	18 (40)	25 (56)	28 (62)	38 (84)	

Notes: 1. The power facility capacity varies depending on the power supply's impedance.

2. The regenerative braking frequency shows the permissible frequency when the motor, without a load and the optional regeneration unit, decelerates from the rated speed to a stop. When a load is connected; however, the value will be the table value/(m+1), where m=the load inertia moment/the motor inertia moment. When the operating speed exceeds the rated speed, the regenerative braking frequency is inversely proportional to the square of (operating speed/rated speed). If the operating speed changes frequently or when the regeneration is constant (as with vertical feeds), find the regenerative heating value (W) in operation. Provisions must be made to keep this heating value below the tolerable regenerative power (W). Optimal regenerative resistor varies for each system. Select the most suitable regenerative resistor by using the Servo Support software. Refer to the section "Options ● Optional regeneration unit" in this catalog for details on the tolerable regenerative power (W).

## HF-SP 2000r/min series servo motor torque characteristics (200VAC class)

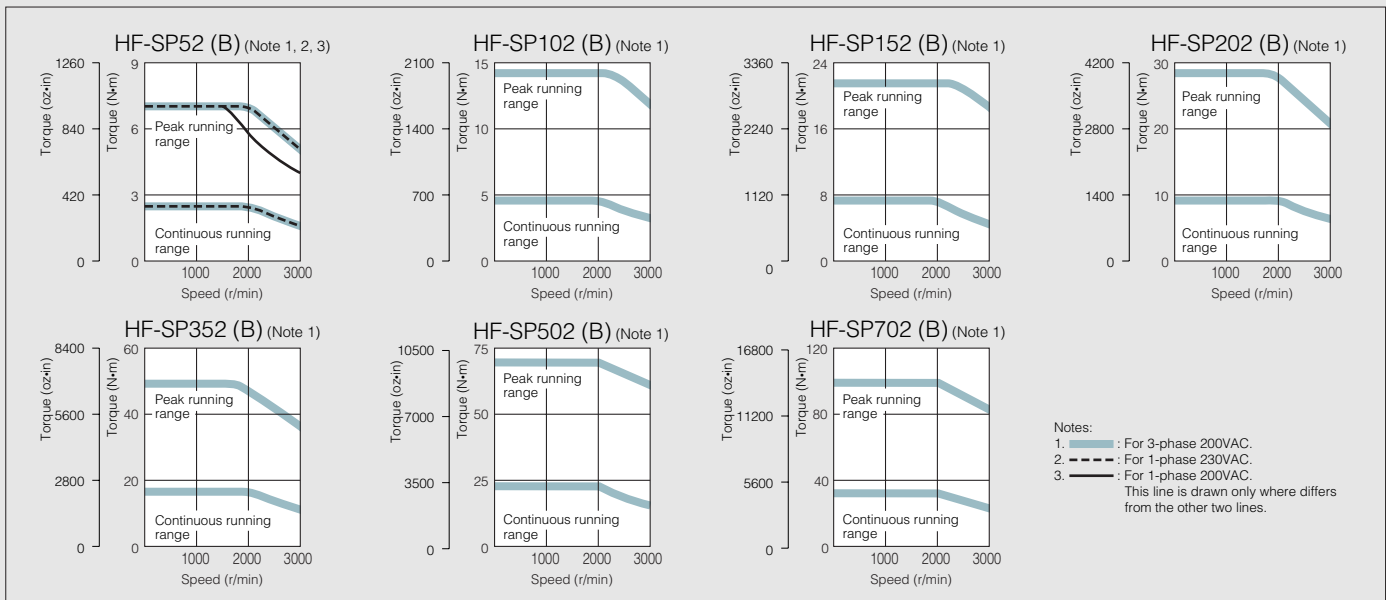

# Motor Specifications and Characteristics



## HF-SP 2000r/min series servo motor specifications (400VAC class)

HF-SP 2000r/min series (Medium inertia, medium capacity)						
524(B)	1024(B)	1524(B)	2024(B)	3524(B)	5024(B)	7024(B)
60A4/B4(-RJ006)/T4	100A4/B4(-RJ006)/T4	200A4/B4(-RJ006)/T4		350A4/B4(-RJ006)/T4	500A4/B4(-RJ006)/T4	700A4/B4(-RJ006)/T4
1.0	1.7	2.5	3.5	5.5	7.5	10
0.5	1.0	1.5	2.0	3.5	5.0	7.0
2.39 (338)	4.77 (675)	7.16 (1010)	9.55 (1350)	16.7 (2360)	23.9 (3380)	33.4 (4730)
7.16 (1010)	14.3 (2020)	21.5 (3040)	28.6 (4050)	50.1 (7090)	71.6 (10100)	100 (14200)
2000						
3000						
3450						
9.34	19.2	28.8	23.8	37.2	58.8	72.5
1.5	2.9	4.1	5.0	8.4	12	16
4.5	8.7	12	15	25	36	48
90	46	154	72	37	34	28
6.1 (33.4)	11.9 (65.1)	17.8 (97.3)	38.3 (209)	75.0 (410)	97.0 (530)	154 (842)
8.3 (45.4)	14.0 (76.5)	20.0 (109)	47.9 (262)	84.7 (463)	107 (585)	164 (897)
15 times the servo motor's inertia moment maximum (Note 3)						
18-bit encoder (Resolution per encoder/servo motor rotation: 262144 p/rev)						
— (Motors with an oil seal are available (HF-SP□J))						
Class F						
Totally enclosed non ventilated (protection level: IP67) (Note 4)						
0 to 40°C (32 to 104°F) (non freezing), storage: -15 to 70°C (5 to 158°F) (non freezing)						
80% RH maximum (non condensing), storage: 90% RH maximum (non condensing)						
Indoors (no direct sunlight); no corrosive gas, inflammable gas, oil mist or dust						
1000m or less above sea level						
X: 24.5m/s <sup>2</sup> Y: 24.5m/s <sup>2</sup>		X: 24.5m/s <sup>2</sup> Y: 49m/s <sup>2</sup>			X: 24.5m/s <sup>2</sup> Y: 29.4m/s <sup>2</sup>	
4.8 (11)	6.7 (15)	8.5 (19)	13 (29)	19 (42)	22 (49)	32 (71)
6.7 (15)	8.6 (19)	11 (25)	19 (42)	25 (56)	28 (62)	38 (84)

3. Contact Mitsubishi if the load/motor of inertia moment ratio exceeds the value in the table.

4. The shaft-through portion is excluded.

5. The vibration direction is shown in the right-side diagram. The numeric value indicates the maximum value of the component (commonly the bracket in the opposite direction of the motor shaft). Fretting of the bearing occurs easily when the motor stops, so maintain vibration to approximately one-half of the allowable value.

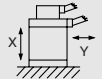

## HF-SP 2000r/min series servo motor torque characteristics (400VAC class)

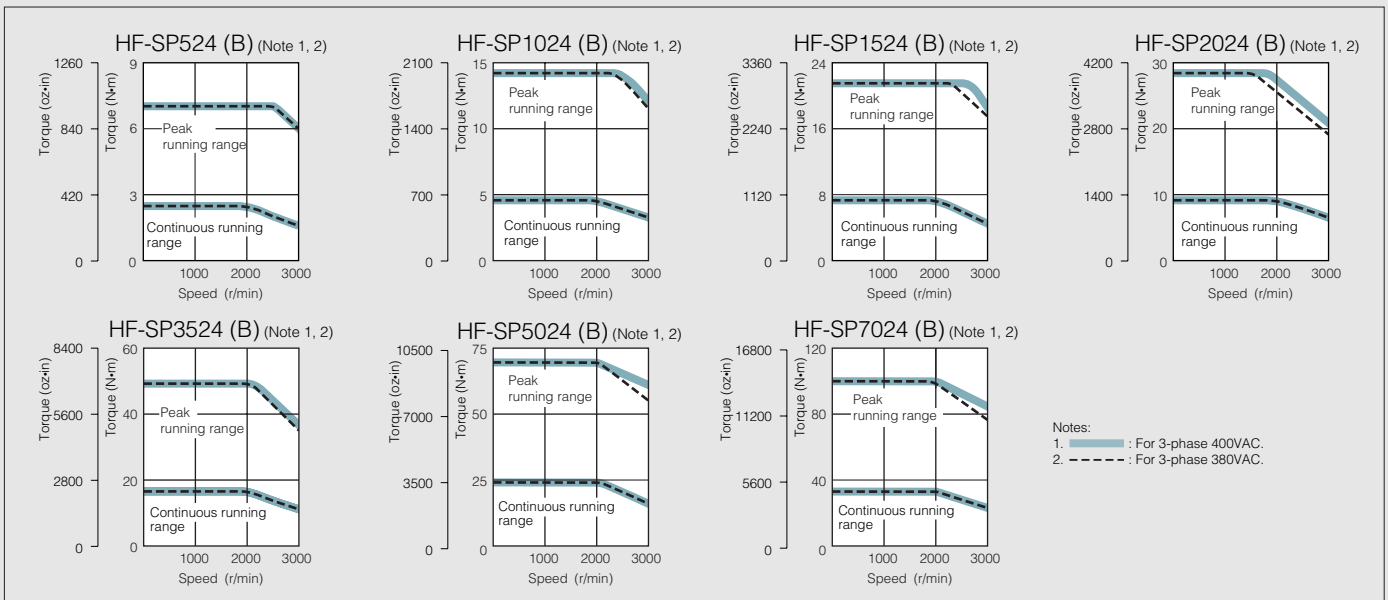

# Motor Specifications and Characteristics



## HA-LP 1000r/min series servo motor specifications (200VAC class)

Servo motor series		HA-LP 1000r/min series (Low inertia, medium/large capacity)								
Servo motor model HA-LP		601(B)	801(B)	12K1(B)	15K1	20K1	25K1	30K1	37K1	
Servo amplifier model MR-J3-		700A/B (-RJ006)/T	11KA/B(-RJ006)/T		15KA/B (-RJ006)/T	22KA/B(-RJ006)/T		DU30KA/B	DU37KA/B	
Servo motor	Power facility capacity (Note 1) (kVA)	8.6	12	18	22	30	38	48	59	
	Continuous running duty	Rated output (kW)	6.0	8.0	12	15	20	25	30	37
		Rated torque (N·m [oz·in])	57.3 (8110)	76.4 (10800)	115 (16300)	143 (20200)	191 (27000)	239 (33800)	286 (40500)	353 (50000)
	Maximum torque (N·m [oz·in])	172 (24400)	229 (32400)	344 (48700)	415 (58800)	477 (67500)	597 (84500)	716 (101000)	883 (125000)	
	Rated speed (r/min)	1000								
	Maximum speed (r/min)	1200								
	Permissible instantaneous speed (r/min)	1380								
	Power rate at continuous rated torque (kW/s)	313	265	445	373	561	528	626	668	
	Rated current (A)	34	42	61	83	118	118	154	188	
	Maximum current (A)	102	126	183	249	295	295	385	470	
	Regenerative braking frequency (times/min) (Note 2)	158	354 (Note 6)	264 (Note 6)	230 (Note 6)	195 (Note 6)	117 (Note 6)	-	-	
	Moment of inertia J ( $\times 10^{-4}$ kg·m <sup>2</sup> ) [J (oz·in <sup>2</sup> )]	Standard	105 (574)	220 (1200)	295 (1610)	550 (3010)	650 (3550)	1080 (5900)	1310 (7160)	1870 (10200)
		With electromagnetic brake	113 (618)	293 (1600)	369 (2020)	-	-	-	-	
	Recommended load/motor inertia moment ratio	10 times the servo motor's inertia moment maximum (Note 3)								
	Speed/position detector	18-bit encoder (Resolution per encoder/servo motor rotation: 262144p/rev)								
Attachments	Oil seal									
Insulation class	Class F									
Structure	Totally enclosed ventilated (protection level: IP44) (Note 4)									
Environment	Ambient temperature	0 to 40°C (32 to 104°F) (non freezing), storage: -15 to 70°C (5 to 158°F) (non freezing)								
	Ambient humidity	80% RH maximum (non condensing), storage: 90% RH maximum (non condensing)								
	Atmosphere	Indoors (no direct sunlight); no corrosive gas, inflammable gas, oil mist or dust								
	Elevation	1000m or less above sea level								
Vibration (Note 5)	X: 11.7m/s <sup>2</sup> Y: 29.4m/s <sup>2</sup>				X: 9.8m/s <sup>2</sup> Y: 9.8m/s <sup>2</sup>					
	Mass (kg [lb])		Standard	55 (125)	95 (210)	115 (255)	160 (355)	180 (400)	230 (510)	250 (555)
	With electromagnetic brake		70 (155)	130 (290)	150 (335)	-	-	-	-	-
Cooling fan	Power	Voltage, frequency	1-phase 200 to 220VAC/50Hz 1-phase 200 to 230VAC/60Hz		3-phase 200 to 230VAC 50/60Hz					
		Input (W)	42 (50Hz) / 54 (60Hz)	62 (50Hz) / 76 (60Hz)	65 (50Hz) / 85 (60Hz)	120 (50Hz) / 175 (60Hz)				
	Rated current (A)	0.21 (50Hz) / 0.25 (60Hz)	0.18 (50Hz) / 0.17 (60Hz)	0.20 (50Hz) / 0.22 (60Hz)	0.65 (50Hz) / 0.80 (60Hz)					

Notes: 1. The power facility capacity varies depending on the power supply's impedance.  
 2. The regenerative braking frequency shows the permissible frequency when the motor, without a load and the optional regeneration unit, decelerates from the rated speed to a stop. When a load is connected; however, the value will be the table value/(m+1), where m=the load inertia moment/the motor inertia moment. When the operating speed exceeds the rated speed, the regenerative braking frequency is inversely proportional to the square of (operating speed/rated speed). If the operating speed changes frequently or when the regeneration is constant (as with vertical feeds), find the regenerative heating value (W) in operation. Provisions must be made to keep this heating value below the tolerable regenerative power (W). Optimal regenerative resistor varies for each system. Select the most suitable regenerative resistor by using the Servo Support software. Refer to the section "Options ● Optional regeneration unit" in this catalog for details on the tolerable regenerative power (W).

## HA-LP 1000r/min series servo motor torque characteristics (200VAC class)

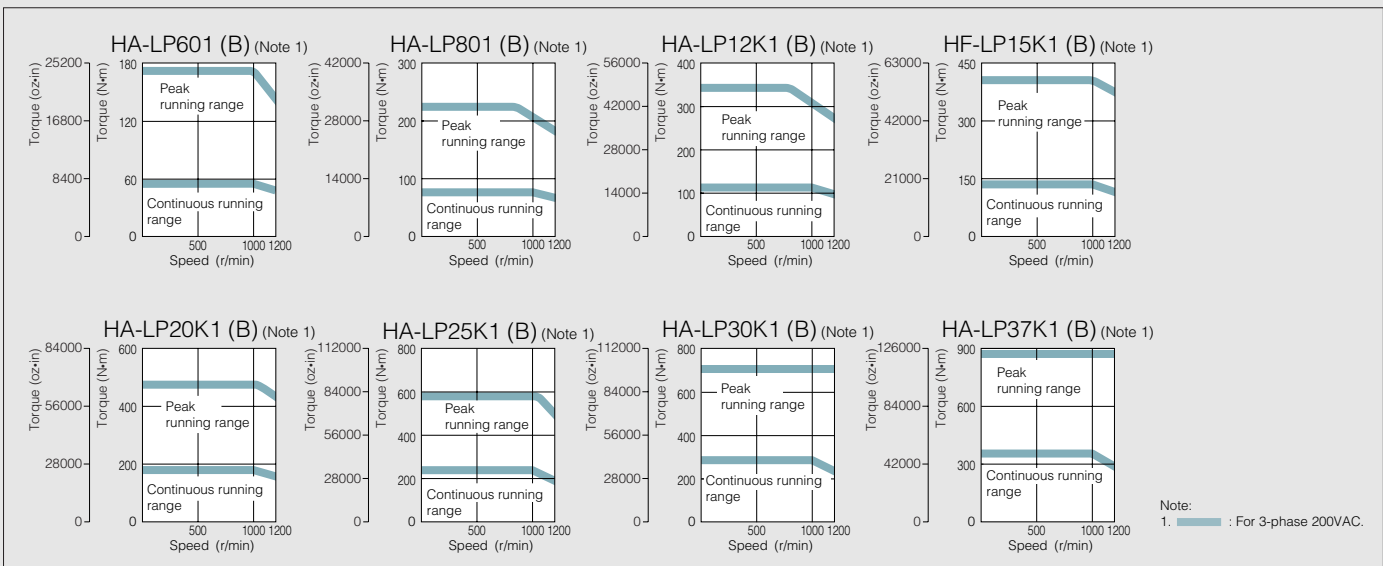

# Motor Specifications and Characteristics



## HA-LP 1000r/min series servo motor specifications (400VAC class)

HA-LP 1000r/min series (Low inertia, medium/large capacity)							
6014(B)	8014(B) (Note 7)	12K14(B)	15K14	20K14 (Note 7)	25K14	30K14	37K14
700A4/B4 (-RJ006)/T4	11KA4/B4(-RJ006)/T4		15KA4/B4 (-RJ006)/T4	22KA4/B4 (-RJ006)/T4	DU30KA4/B4		DU37KA4/B4
8.6	12	18	22	30	38	48	59
6.0	8.0	12	15	20	25	30	37
57.3 (8110)	76.4 (10800)	115 (16300)	143 (20200)	191 (27000)	239 (33800)	286 (40500)	353(50000)
172 (24400)	229 (32400)	344 (48700)	415 (58800)	477 (67500)	597 (84500)	716 (101000)	883 (125000)
1000							
1200							
1380							
313	265	445	373	561	528	626	668
17	20	30	40	55	70	77	95
51	60	90	120	138	175	193	238
169	354 (Note 6)	264 (Note 6)	230 (Note 6)	195 (Note 6)	-	-	-
105 (574)	220 (1200)	295 (1610)	550 (3010)	650 (3550)	1080 (5900)	1310 (7160)	1870 (10200)
113 (618)	293 (1600)	369 (2020)	-	-	-	-	-
10 times the servo motor's inertia moment maximum (Note 3)							
18-bit encoder (Resolution per encoder/servo motor rotation: 262144 p/rev)							
Oil seal							
Class F							
Totally enclosed ventilated (protection level: IP44)(Note 4)							
0 to 40°C (32 to 104°F) (non freezing), storage: -15 to 70°C (5 to 158°F) (non freezing)							
80% RH maximum (non condensing), storage: 90% RH maximum (non condensing)							
Indoors (no direct sunlight); no corrosive gas, inflammable gas, oil mist or dust							
1000m or less above sea level							
X: 11.7m/s <sup>2</sup> Y: 29.4m/s <sup>2</sup>				X: 9.8m/s <sup>2</sup> Y: 9.8m/s <sup>2</sup>			
55 (125)	95 (210)	115 (255)	160 (355)	180 (400)	230 (510)	250 (555)	335 (740)
70 (155)	130 (290)	150 (335)	-	-	-	-	-
1-phase 200 to 220VAC/50Hz 1-phase 200 to 230VAC/60Hz	3-phase 380 to 440VAC/50Hz 3-phase 380 to 480VAC/60Hz		3-phase 380 to 460VAC/50Hz 3-phase 380 to 480VAC/60Hz				
42 (50Hz) / 54 (60Hz)	62 (50Hz) / 76 (60Hz)		65 (50Hz) / 85 (60Hz)		110 (50Hz) / 150 (60Hz)		
0.21 (50Hz) / 0.25 (60Hz)	0.14 (50Hz) / 0.11 (60Hz)		0.12 (50Hz) / 0.14 (60Hz)		0.20 (50Hz) / 0.22 (60Hz)		

3. Contact Mitsubishi if the load/motor of inertia moment ratio exceeds the value in the table.

4. The shaft-through portion is excluded.

5. The vibration direction is shown in the right-side diagram. The numeric value indicates the maximum value of the component (commonly the bracket in the opposite direction of the motor shaft). Fretting of the bearing occurs easily when the motor stops, so maintain vibration to approximately one-half of the allowable value.

6. The value applies when the external regenerative resistors, GRZG400-□Ω, (standard accessory) are used with cooling fans (2 units of 92 × 92mm, minimum air flow: 1.0m<sup>3</sup>/min). Note that change in the parameter No. PA02 is required.

7. Contact your dealer for the delivery schedule and the compatible servo amplifier software version.

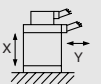

## HA-LP 1000r/min series servo motor torque characteristics (400VAC class)

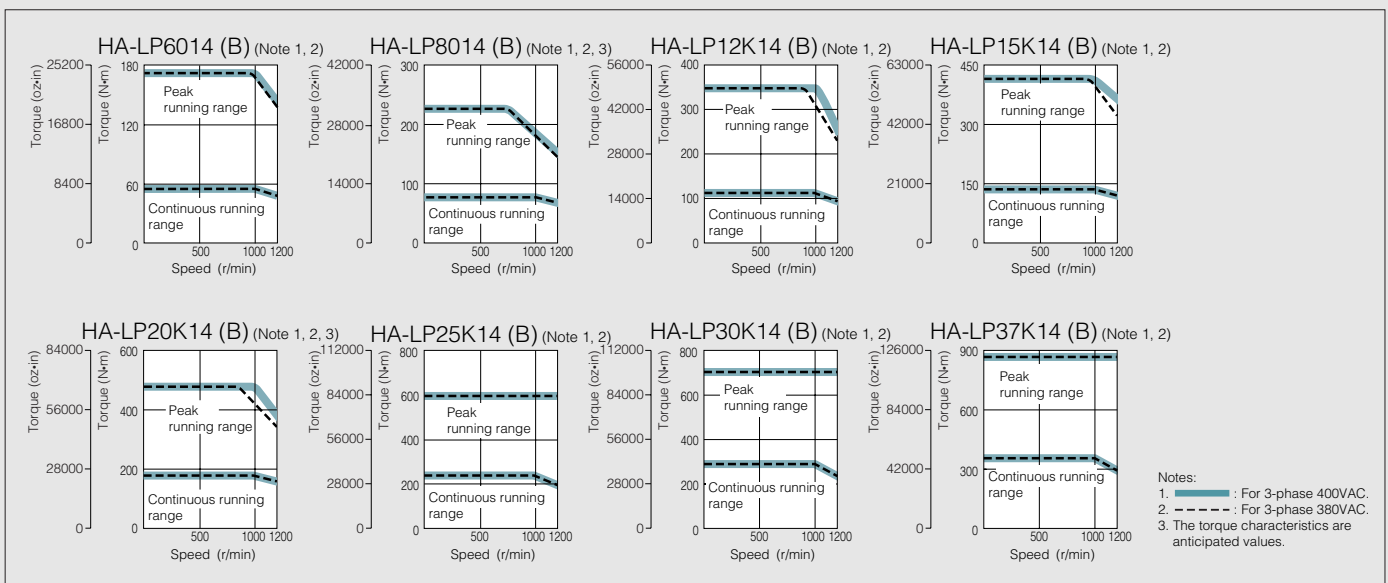

# Motor Specifications and Characteristics

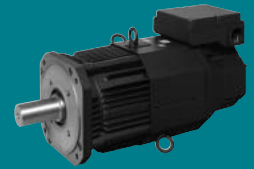

## HA-LP 1500r/min series servo motor specifications (200VAC class)

Servo motor series		HA-LP 1500r/min series (Low inertia, medium/large capacity)						
Servo motor model	HA-LP	701M(B)	11K1M(B)	15K1M(B)	22K1M	30K1M	37K1M	
Servo amplifier model	MR-J3-	700A/B(-RJ006)/T	11KA/B(-RJ006)/T	15KA/B(-RJ006)/T	22KA/B(-RJ006)/T	DU30KA/B	DU37KA/B	
Servo motor	Power facility capacity (Note 1) (kVA)	10	16	22	33	48	59	
	Continuous running duty	Rated output (kW)	7.0	11	15	22	30	37
		Rated torque (N·m [oz·in])	44.6 (6320)	70.0 (9910)	95.5 (13500)	140 (19800)	191 (27000)	236 (33400)
	Maximum torque (N·m [oz·in])	134 (19000)	210 (29700)	286 (40500)	350 (49600)	477 (67500)	589 (83400)	
	Rated speed (r/min)	1500						
	Maximum speed (r/min)	2000						
	Permissible instantaneous speed (r/min)	2300						
	Power rate at continuous rated torque (kW/s)	189	223	309	357	561	514	
	Rated current (A)	37	65	87	126	174	202	
	Maximum current (A)	111	195	261	315	435	505	
	Regenerative braking frequency (times/min) (Note 2)	70	158 (Note 6)	191 (Note 6)	102 (Note 6)	—	—	
	Moment of inertia J ( $\times 10^{-4}$ kg·m <sup>2</sup> ) [J (oz·in <sup>2</sup> )]	Standard	105 (574)	220 (1200)	295 (1610)	550 (3010)	650 (3550)	1080 (5900)
		With electromagnetic brake	113 (618)	293 (1600)	369 (2020)	—	—	—
	Recommended load/motor inertia moment ratio	10 times the servo motor's inertia moment maximum (Note 3)						
	Speed/position detector	18-bit encoder (Resolution per encoder/servo motor rotation: 262144 p/rev)						
	Attachments	Oil seal						
	Insulation class	Class F						
Structure	Totally enclosed ventilated (protection level: IP44) (Note 4)							
Environment	Ambient temperature	0 to 40°C (32 to 104°F) (non freezing), storage: -15 to 70°C (5 to 158°F) (non freezing)						
	Ambient humidity	80% RH maximum (non condensing), storage: 90% RH maximum (non condensing)						
	Atmosphere	Indoors (no direct sunlight); no corrosive gas, inflammable gas, oil mist or dust						
	Elevation	1000m or less above sea level						
Vibration (Note 5)	X: 11.7m/s <sup>2</sup> Y: 29.4m/s <sup>2</sup>			X: 9.8m/s <sup>2</sup> Y: 9.8m/s <sup>2</sup>				
Mass (kg [lb])	Standard	55 (125)	95 (210)	115 (255)	160 (355)	180 (400)	230 (510)	
	With electromagnetic brake	70 (155)	130 (290)	150 (335)	—	—	—	
Cooling fan	Power	Voltage, frequency	1-phase 200 to 220VAC/50Hz 1-phase 200 to 230VAC/60Hz		3-phase 200 to 230VAC 50/60Hz			
		Input (W)	42 (50Hz) / 54 (60Hz)		62 (50Hz) / 76 (60Hz)		65 (50Hz) / 85 (60Hz) / 120 (50Hz) / 175 (60Hz)	
	Rated current (A)	0.21 (50Hz) / 0.25 (60Hz)		0.18 (50Hz) / 0.17 (60Hz)		0.20 (50Hz) / 0.22 (60Hz)		0.65 (50Hz) / 0.80 (60Hz)

Notes: 1. The power facility capacity varies depending on the power supply's impedance.

2. The regenerative braking frequency shows the permissible frequency when the motor, without a load and the optional regeneration unit, decelerates from the rated speed to a stop. When a load is connected; however, the value will be the table value/(m+1), where m=the load inertia moment/the motor inertia moment. When the operating speed exceeds the rated speed, the regenerative braking frequency is inversely proportional to the square of (operating speed/rated speed). If the operating speed changes frequently or when the regeneration is constant (as with vertical feeds), find the regenerative heating value (W) in operation. Provisions must be made to keep this heating value below the tolerable regenerative power (W). Optimal regenerative resistor varies for each system. Select the most suitable regenerative resistor by using the Servo Support software. Refer to the section "Options ● Optional regeneration unit" in this catalog for details on the tolerable regenerative power (W).

## HA-LP 1500r/min series servo motor torque characteristics (200VAC class)

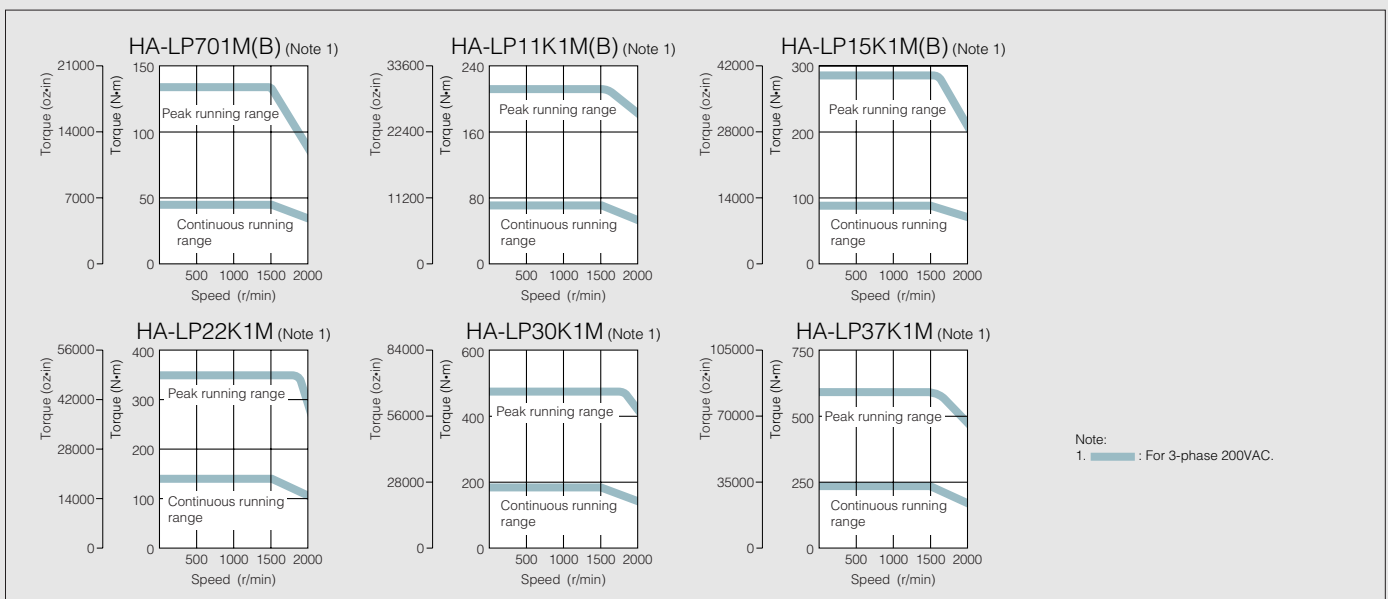

# Motor Specifications and Characteristics



## HA-LP 1500r/min series servo motor specifications (400VAC class)

HA-LP 1500r/min series (Low inertia, medium/large capacity)								
701M4(B)	11K1M4(B) (Note 7)	15K1M4(B)	22K1M4	30K1M4	37K1M4	45K1M4	50K1M4	
700A4/B4(-RJ006)/T4	11KA4/B4(-RJ006)/T4	15KA4/B4(-RJ006)/T4	22KA4/B4(-RJ006)/T4	DU30KA4/B4	DU37KA4/B4	DU45KA4/B4	DU55KA4/B4	
10	16	22	33	48	59	71	80	
7.0	11	15	22	30	37	45	50	
44.6 (6320)	70.0 (9910)	95.5 (13500)	140 (19800)	191 (27000)	236 (33400)	286 (40500)	318 (45000)	
134 (19000)	210 (29700)	286 (40500)	350 (49600)	477 (67500)	589 (83400)	716 (101000)	796 (113000)	
1500								
2000								
2300								
189	223	309	357	561	514	626	542	
18	31	41	63	87	101	128	143	
54	93	123	158	218	253	320	358	
75	158 (Note 6)	191 (Note 6)	102 (Note 6)	—	—	—	—	
105 (574)	220 (1200)	295 (1610)	550 (3010)	650 (3550)	1080 (5900)	1310 (7160)	1870 (10200)	
113 (618)	293 (1600)	369 (2020)	—	—	—	—	—	
10 times the servo motor's inertia moment maximum (Note 3)								
18-bit encoder (Resolution per encoder/servo motor rotation: 262144 p/rev)								
Oil seal								
Class F								
Totally enclosed ventilated (protection level: IP44) (Note 4)								
0 to 40°C (32 to 104°F) (non freezing), storage: -15 to 70°C (5 to 158°F) (non freezing)								
80% RH maximum (non condensing), storage: 90% RH maximum (non condensing)								
Indoors (no direct sunlight); no corrosive gas, inflammable gas, oil mist or dust								
1000m or less above sea level								
X: 11.7m/s <sup>2</sup> Y: 29.4m/s <sup>2</sup>				X: 9.8m/s <sup>2</sup> Y: 9.8m/s <sup>2</sup>				
55 (125)	95 (210)	115 (255)	160 (355)	180 (400)	230 (510)	250 (555)	335 (740)	
70 (155)	130 (290)	150 (335)	—	—	—	—	—	
1-phase 200 to 220VAC/50Hz 1-phase 200 to 230VAC/60Hz	3-phase 380 to 440VAC/50Hz 3-phase 380 to 480VAC/60Hz			3-phase 380 to 460VAC/50Hz 3-phase 380 to 480VAC/60Hz				
42 (50Hz) / 54 (60Hz)	62 (50Hz) / 76 (60Hz)		65 (50Hz) / 85 (60Hz)		110 (50Hz) / 150 (60Hz)			
0.21 (50Hz) / 0.25 (60Hz)	0.14 (50Hz) / 0.11 (60Hz)		0.12 (50Hz) / 0.14 (60Hz)		0.20 (50Hz) / 0.22 (60Hz)			

- Contact Mitsubishi if the load/motor of inertia moment ratio exceeds the value in the table.
- The shaft-through portion is excluded.
- The vibration direction is shown in the right-side diagram. The numeric value indicates the maximum value of the component (commonly the bracket in the opposite direction of the motor shaft). Fretting of the bearing occurs easily when the motor stops, so maintain vibration to approximately one-half of the allowable value.
- The value applies when the external regenerative resistors, GRZG400-□Ω, (standard accessory) are used with cooling fans (2 units of 92 X 92mm, minimum air flow: 1.0m<sup>3</sup>/min). Note that change in the parameter No. PA02 is required.
- Contact your dealer for the delivery schedule and the compatible servo amplifier software version.

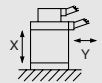

## HA-LP 1500r/min series servo motor torque characteristics (400VAC class)

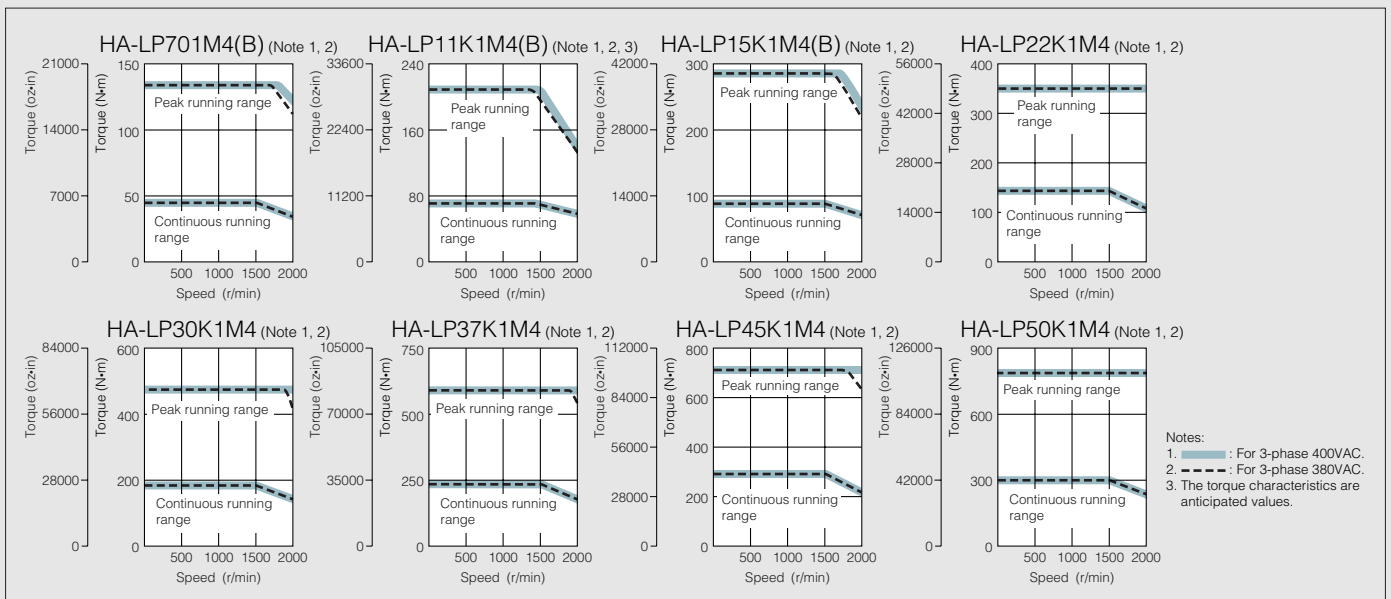

# Motor Specifications and Characteristics



## HA-LP 2000r/min series servo motor specifications (200VAC class)

Servo motor series		HA-LP 2000r/min series (Low inertia, medium/large capacity)							
Servo motor model	HA-LP	502	702	11K2(B)	15K2(B)	22K2(B)	30K2	37K2	
Servo amplifier model	MR-J3-	500A/B(-RJ006)/T	700A/B(-RJ006)/T	11KA/B(-RJ006)/T	15KA/B(-RJ006)/T	22KA/B(-RJ006)/T	DU30KA/B	DU37KA/B	
Servo motor	Power facility capacity (Note 1) (kVA)	7.5	10.0	16	22	33	48	59	
	Continuous running duty	Rated output (kW)	5.0	7.0	11	15	22	30	37
		Rated torque (N·m [oz·in])	23.9 (3380)	33.4 (4730)	52.5 (7430)	71.6 (10100)	105 (14900)	143 (20200)	177 (25100)
	Maximum torque (N·m [oz·in])	71.6 (10100)	100 (14200)	158 (22400)	215 (30400)	263 (37200)	358 (50700)	442 (62600)	
	Rated speed (r/min)	2000							
	Maximum speed (r/min)	2000							
	Permissible instantaneous speed (r/min)	2300							
	Power rate at continuous rated torque (kW/s)	77.2	118	263	233	374	373	480	
	Rated current (A)	25	34	63	77	112	166	204	
	Maximum current (A)	75	102	189	231	280	415	510	
	Regenerative braking frequency (times/min) (Note 2)	50	50	186 (Note 6)	144 (Note 6)	107 (Note 6)	—	—	
	Moment of inertia J ( $\times 10^{-4}$ kg·m <sup>2</sup> ) [J (oz·in <sup>2</sup> )]	Standard	74.0 (405)	94.2 (515)	105 (574)	220 (1200)	295 (1610)	550 (3010)	650 (3550)
		With electromagnetic brake	—	—	113 (618)	293 (1600)	369 (2020)	—	—
	Recommended load/motor inertia moment ratio	10 times the servo motor's inertia moment maximum (Note 3)							
	Speed/position detector	18-bit encoder (Resolution per encoder/servo motor rotation: 262144 p/rev)							
Attachments	Oil seal								
Insulation class	Class F								
Structure	Totally enclosed non ventilated (protection level: IP65) (Note 4)			Totally enclosed ventilated (protection level: IP44) (Note 4)					
Environment	Ambient temperature	0 to 40°C (32 to 104°F) (non freezing), storage: -15 to 70°C (5 to 158°F) (non freezing)							
	Ambient humidity	80% RH maximum (non condensing), storage: 90% RH maximum (non condensing)							
	Atmosphere	Indoors (no direct sunlight); no corrosive gas, inflammable gas, oil mist or dust							
	Elevation	1000m or less above sea level							
	Vibration (Note 5)	X: 11.7m/s <sup>2</sup> Y: 29.4m/s <sup>2</sup>					X: 9.8m/s <sup>2</sup> Y: 9.8m/s <sup>2</sup>		
Mass (kg [lb])	Standard	28 (62)	35 (78)	55 (125)	95 (210)	115 (255)	160 (355)	180 (400)	
	With electromagnetic brake	—	—	70 (155)	130 (290)	150 (335)	—	—	
Cooling fan	Power	Voltage, frequency	—		1-phase 200 to 220VAC/60Hz 1-phase 200 to 230VAC/60Hz	3-phase 200 to 230VAC 50/60Hz			
		Input (W)	—		42 (50Hz) / 54 (60Hz)	62 (50Hz) / 76 (60Hz)		65 (50Hz) / 85 (60Hz)	
	Rated current (A)	—		0.21 (50Hz) / 0.25 (60Hz)	0.18 (50Hz) / 0.17 (60Hz)		0.20 (50Hz) / 0.22 (60Hz)		

Notes: 1. The power facility capacity varies depending on the power supply's impedance.

2. The regenerative braking frequency shows the permissible frequency when the motor, without a load and the optional regeneration unit, decelerates from the rated speed to a stop. When a load is connected; however, the value will be the table value/(m+1), where m=the load inertia moment/the motor inertia moment. When the operating speed exceeds the rated speed, the regenerative braking frequency is inversely proportional to the square of (operating speed/rated speed). If the operating speed changes frequently or when the regeneration is constant (as with vertical feeds), find the regenerative heating value (W) in operation. Provisions must be made to keep this heating value below the tolerable regenerative power (W). Optimal regenerative resistor varies for each system. Select the most suitable regenerative resistor by using the Servo Support software. Refer to the section "Options ● Optional regeneration unit" in this catalog for details on the tolerable regenerative power (W).

## HA-LP 2000r/min series servo motor torque characteristics (200VAC class)

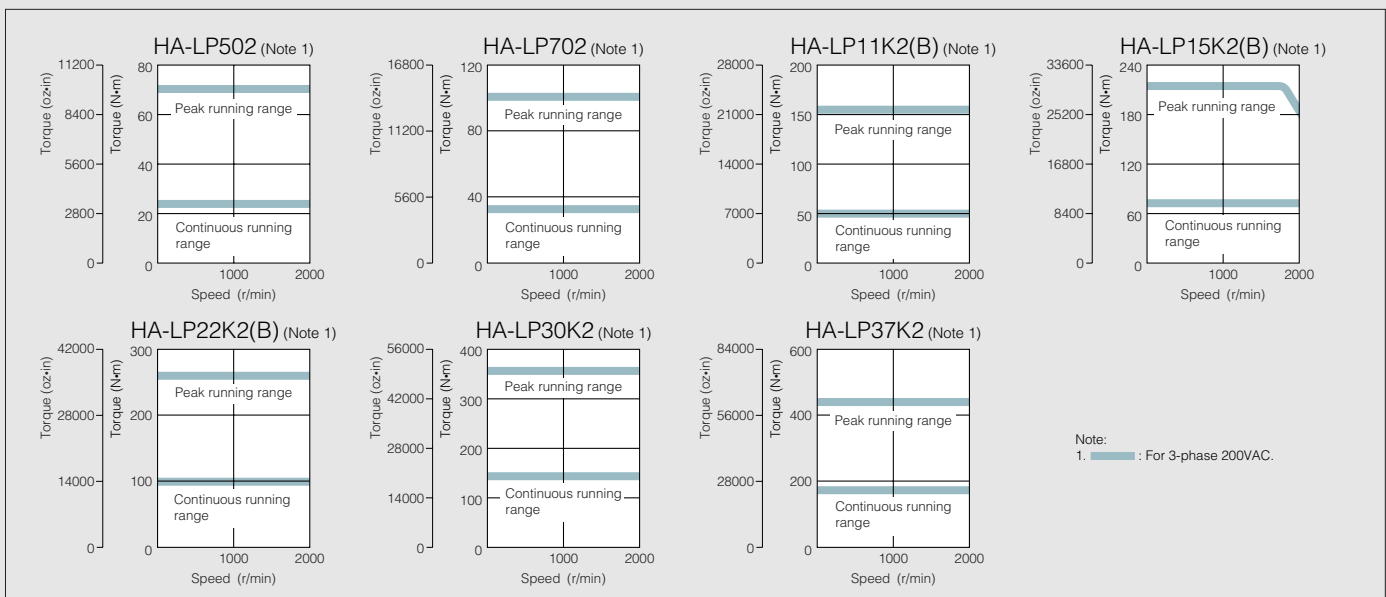



# Motor Specifications and Characteristics



## HA-LP 2000r/min series servo motor specifications (400VAC class)

HA-LP 2000r/min series (Low inertia, medium/large capacity)						
11K24(B)	15K24(B)	22K24(B)	30K24	37K24	45K24	55K24
11KA4/B4(-RJ006)/T4	15KA4/B4(-RJ006)/T4	22KA4/B4(-RJ006)/T4	DU30KA4/B4	DU37KA4/B4	DU45KA4/B4	DU55KA4/B4
16	22	33	48	59	71	87
11	15	22	30	37	45	55
52.5 (7430)	71.6 (10100)	105 (14900)	143 (20200)	177 (25100)	215 (30400)	263 (37200)
158 (22400)	215 (30400)	263 (37200)	358 (50700)	442 (62600)	537 (76000)	657 (93000)
2000						
2000						
2300						
263	233	374	373	480	427	526
32	40	57	83	102	131	143
96	120	143	208	255	328	358
186 (Note 6)	144 (Note 6)	107 (Note 6)	—	—	—	—
105 (574)	220 (1200)	295 (1610)	550 (3010)	650 (3550)	1080 (5900)	1310 (7160)
113 (618)	293 (1600)	369 (2020)	—	—	—	—
10 times the servo motor's inertia moment maximum (Note 3)						
18-bit encoder (Resolution per encoder/servo motor rotation: 262144 p/rev)						
Oil seal						
Class F						
Totally enclosed ventilated (protection level: IP44) (Note 4)						
0 to 40°C (32 to 104°F) (non freezing), storage: -15 to 70°C (5 to 158°F) (non freezing)						
80% RH maximum (non condensing), storage: 90% RH maximum (non condensing)						
Indoors (no direct sunlight); no corrosive gas, inflammable gas, oil mist or dust						
1000m or less above sea level						
X: 11.7m/s <sup>2</sup> Y: 29.4m/s <sup>2</sup>			X: 9.8m/s <sup>2</sup> Y: 9.8m/s <sup>2</sup>			
55 (125)	95 (210)	115 (255)	160 (355)	180 (400)	230 (510)	250 (555)
70 (155)	130 (290)	150 (335)	—	—	—	—
1-phase 200 to 220VAC/50Hz 1-phase 200 to 230VAC/60Hz	3-phase 380 to 440VAC/50Hz 3-phase 380 to 480VAC/60Hz		3-phase 380 to 460VAC/50Hz 3-phase 380 to 480VAC/60Hz			
42 (50Hz) / 54 (60Hz)	62 (50Hz) / 76 (60Hz)		65 (50Hz) / 85 (60Hz)		110 (50Hz) / 150 (60Hz)	
0.21 (50Hz) / 0.25 (60Hz)	0.14 (50Hz) / 0.11 (60Hz)		0.12 (50Hz) / 0.14 (60Hz)		0.20 (50Hz) / 0.22 (60Hz)	

3. Contact Mitsubishi if the load/motor of inertia moment ratio exceeds the value in the table.

4. The shaft-through portion is excluded.

5. The vibration direction is shown in the right-side diagram. The numeric value indicates the maximum value of the component (commonly the bracket in the opposite direction of the motor shaft). Fretting of the bearing occurs easily when the motor stops, so maintain vibration to approximately one-half of the allowable value.

6. The value applies when the external regenerative resistors, GRZG400-□Ω, (standard accessory) are used with cooling fans (2 units of 92 X 92mm, minimum air flow: 1.0m<sup>3</sup>/min). Note that change in the parameter No. PA02 is required.

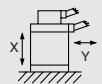

## HA-LP 2000r/min series servo motor torque characteristics (400VAC class)

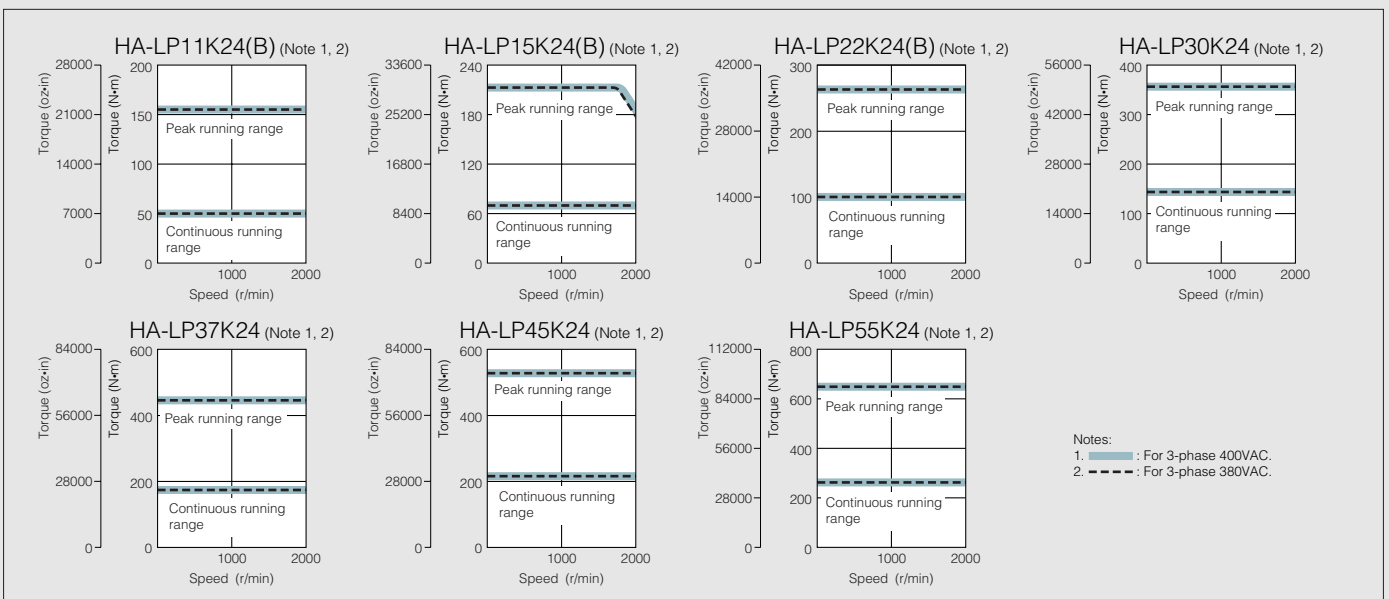

# Motor Dimensions

(Unit: mm)

- HF-KP053(B), HF-KP13(B)
- HF-MP053(B), HF-MP13(B)

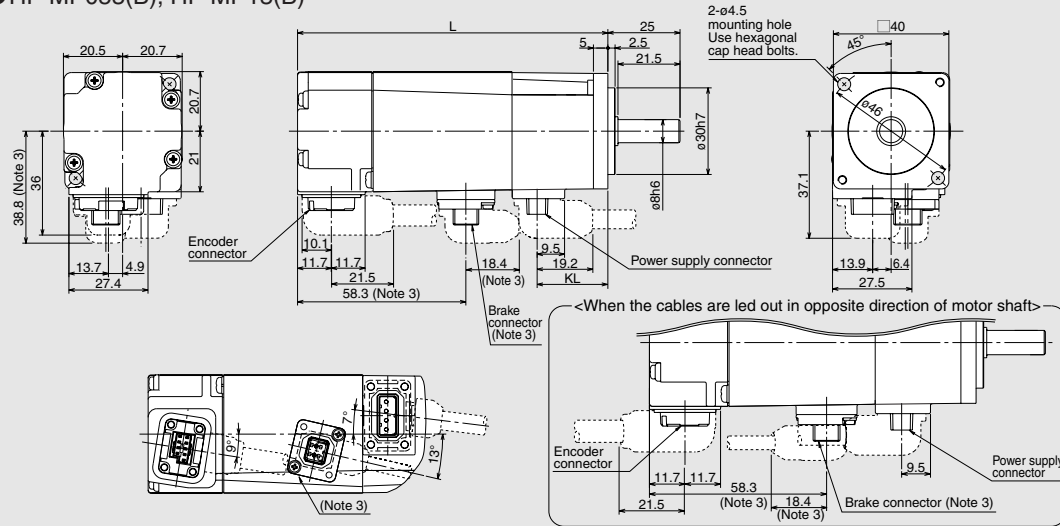

Power supply connector pin assignment

Pin No.	Signal name
1	Earth
2	U
3	V
4	W

Brake connector pin assignment (Note 3)

Pin No.	Signal name
1	B1
2	B2

Model	Variable dimensions	
	L	KL
HF-KP053(B) HF-MP053(B)	66.4 (107.5)	24.5
HF-KP13(B) HF-MP13(B)	82.4 (123.5)	40.5

- HF-KP23(B), HF-KP43(B)
- HF-MP23(B), HF-MP43(B)

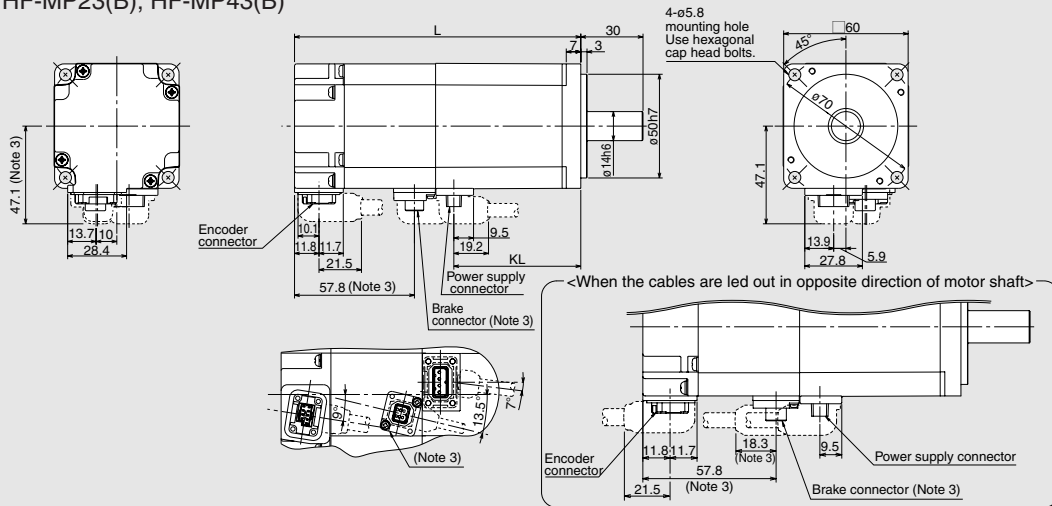

Power supply connector pin assignment

Pin No.	Signal name
1	Earth
2	U
3	V
4	W

Brake connector pin assignment (Note 3)

Pin No.	Signal name
1	B1
2	B2

Model	Variable dimensions	
	L	KL
HF-KP23(B) HF-MP23(B)	76.6 (116.1)	39.3
HF-KP43(B) HF-MP43(B)	98.5 (138)	61.2

- HF-KP73(B)
- HF-MP73(B)

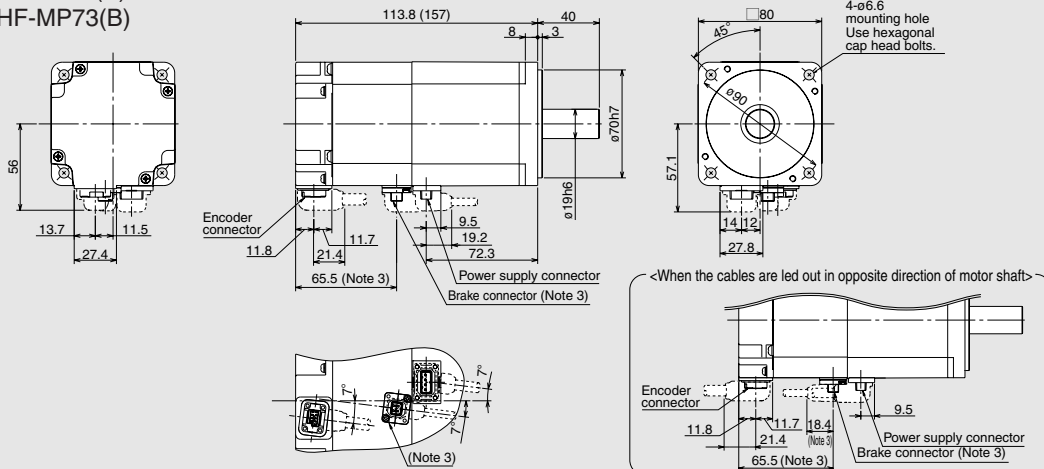

Power supply connector pin assignment

Pin No.	Signal name
1	Earth
2	U
3	V
4	W

Brake connector pin assignment (Note 3)

Pin No.	Signal name
1	B1
2	B2

Notes:

1. Use a friction coupling to fasten a load.
2. Dimensions inside ( ) are for the models with an electromagnetic brake.
3. Only for the models with an electromagnetic brake. The electromagnetic brake terminals (B1, B2) do not have polarity.
4. For dimensions where there is no tolerance listed, use general tolerance.
5. Dimensions for motors with an oil seal (HF-KP□J and HF-MP□J) are different from the above. Contact Mitsubishi for details.

# Motor Dimensions

(Unit: mm)

- HF-SP51(B), HF-SP81(B)
- HF-SP52(B) to HF-SP152(B), HF-SP524(B) to HF-SP152(B)

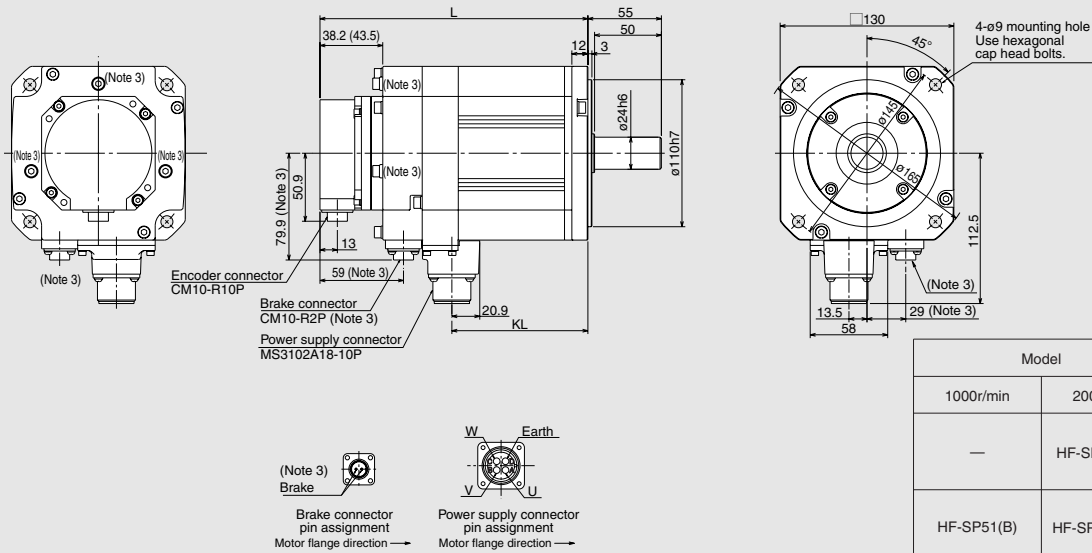

Model		Variable dimensions	
1000r/min	2000r/min	L	KL
—	HF-SP52(4)(B)	118.5 (153)	57.8
HF-SP51(B)	HF-SP102(4)(B)	140.5 (175)	79.8
HF-SP81(B)	HF-SP152(4)(B)	162.5 (197)	101.8

- HF-SP121(B) to HF-SP421(B)
- HF-SP202(B) to HF-SP702(B), HF-SP2024(B) to HF-SP7024(B)

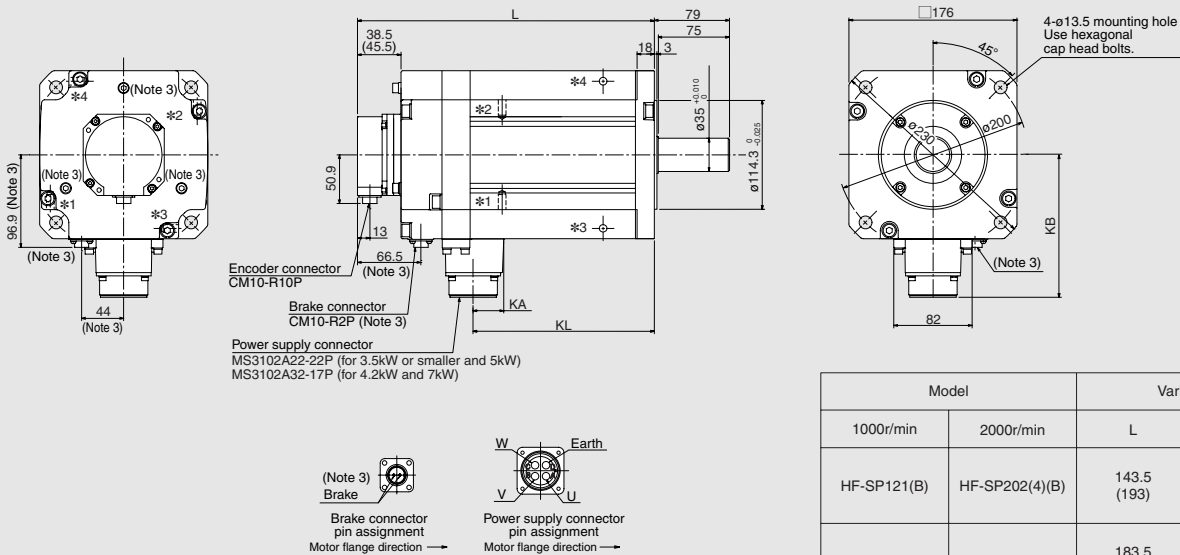

Model		Variable dimensions			
1000r/min	2000r/min	L	KL	KA	KB
HF-SP121(B)	HF-SP202(4)(B)	143.5 (193)	79.8		
HF-SP201(B)	HF-SP352(4)(B)	183.5 (233)	119.8	24.8	140.9
HF-SP301(B)	HF-SP502(4)(B)	203.5 (253)	139.8		
HF-SP421(B)	HF-SP702(4)(B)	263.5 (313)	191.8	32	149.1

- \*1, \*2, \*3 and \*4 are screw holes for hanging bolt.
- For HF-SP201(B), HF-SP301(B), HF-SP352(4)(B), HF-SP502(4)(B): \*3, \*4
- For HF-SP421(B), HF-SP702(4)(B): \*1, \*2, \*3, \*4

**Notes:**

1. Use a friction coupling to fasten a load.
2. Dimensions inside ( ) are for the models with an electromagnetic brake.
3. Only for the models with an electromagnetic brake. The electromagnetic brake terminals do not have polarity.
4. For dimensions where there is no tolerance listed, use general tolerance.

# Motor Dimensions

(Unit: mm)

## ●HC-LP52(B) to HC-LP152(B)

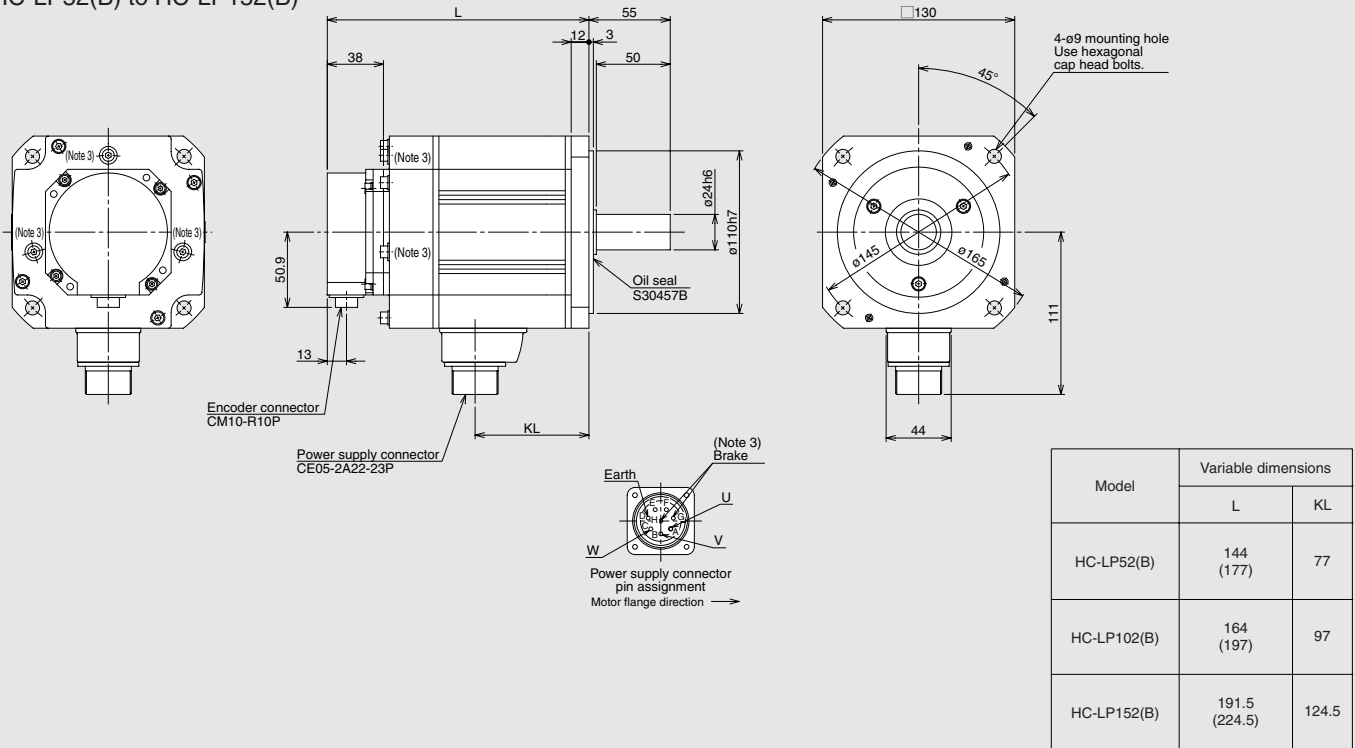

## ●HC-LP202(B), HC-LP302(B)

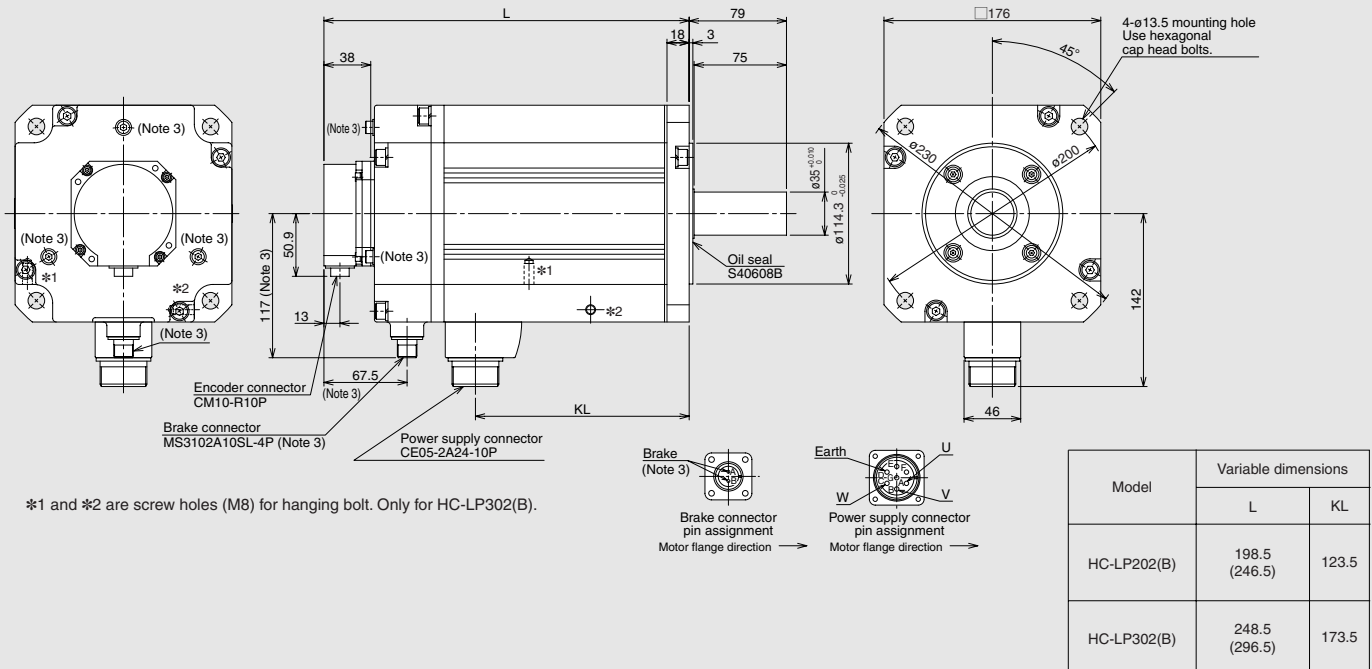

- Notes:
1. Use a friction coupling to fasten a load.
  2. Dimensions inside ( ) are for the models with an electromagnetic brake.
  3. Only for the models with an electromagnetic brake. The electromagnetic brake terminals do not have polarity.
  4. For dimensions where there is no tolerance listed, use general tolerance.

# Motor Dimensions

(Unit: mm)

## ● HC-RP103(B) to HC-RP203(B)

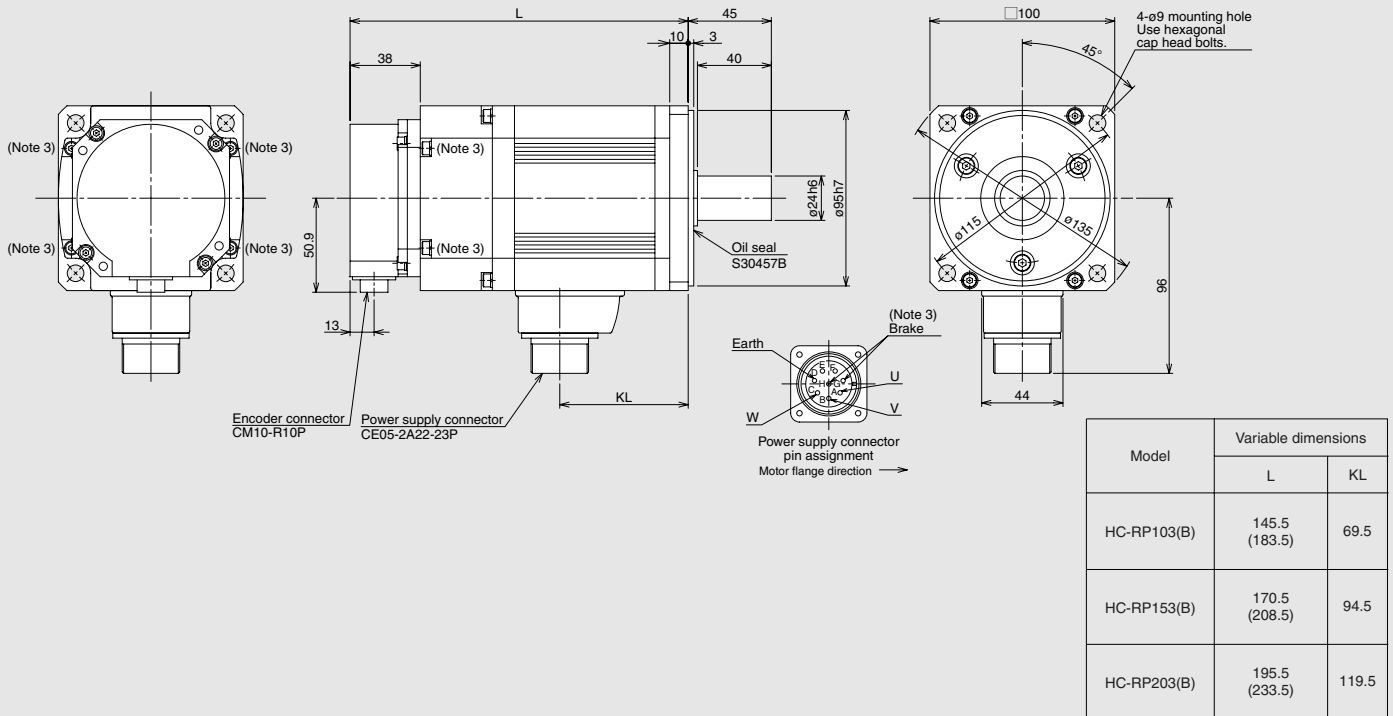

## ● HC-RP353(B), HC-RP503(B)

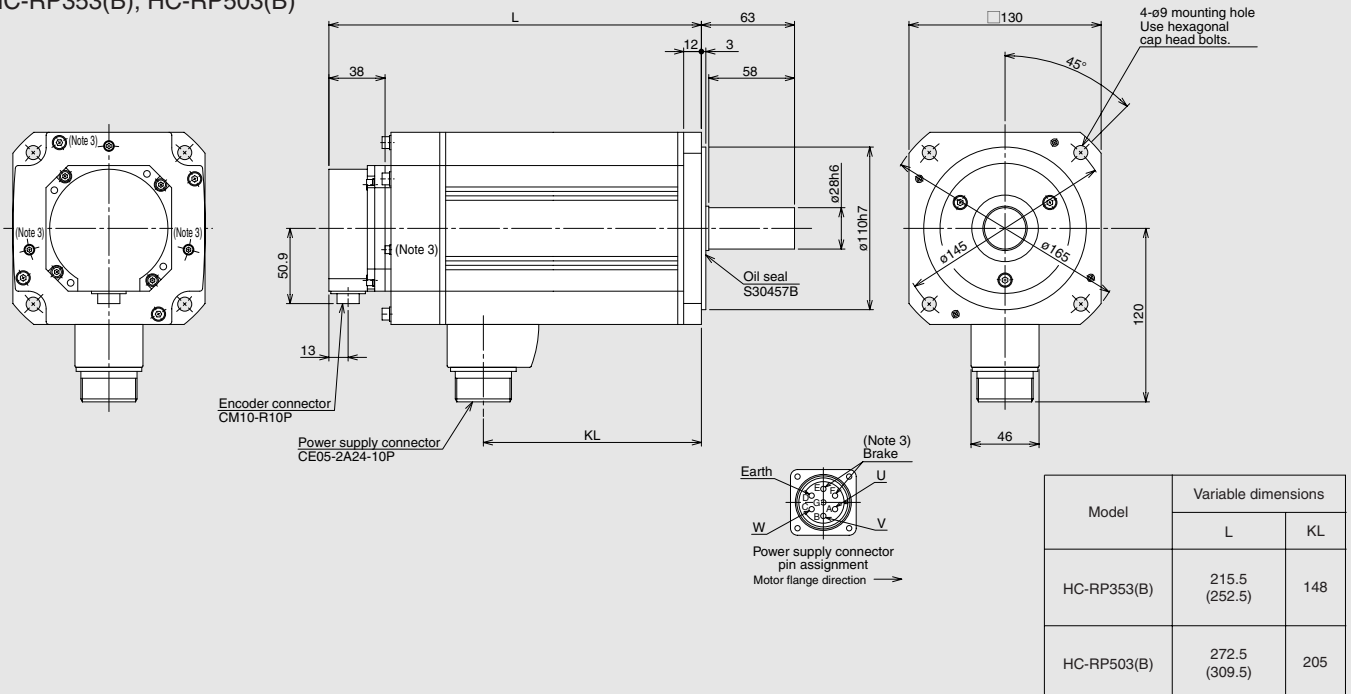

### Notes:

1. Use a friction coupling to fasten a load.
2. Dimensions inside ( ) are for the models with an electromagnetic brake.
3. Only for the models with an electromagnetic brake. The electromagnetic brake terminals do not have polarity.
4. For dimensions where there is no tolerance listed, use general tolerance.

# Motor Dimensions

(Unit: mm)

## ●HC-UP72(B), HC-UP152(B)

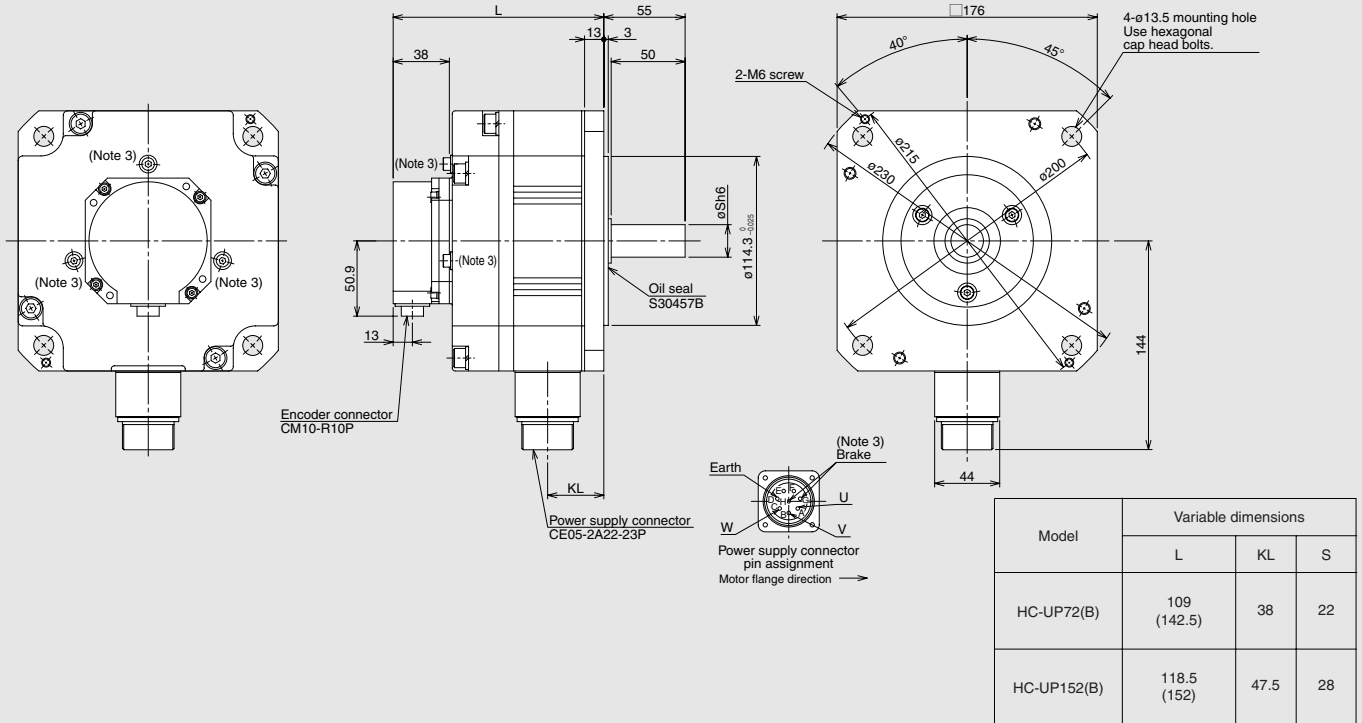

## ●HC-UP202(B) to HC-UP502(B)

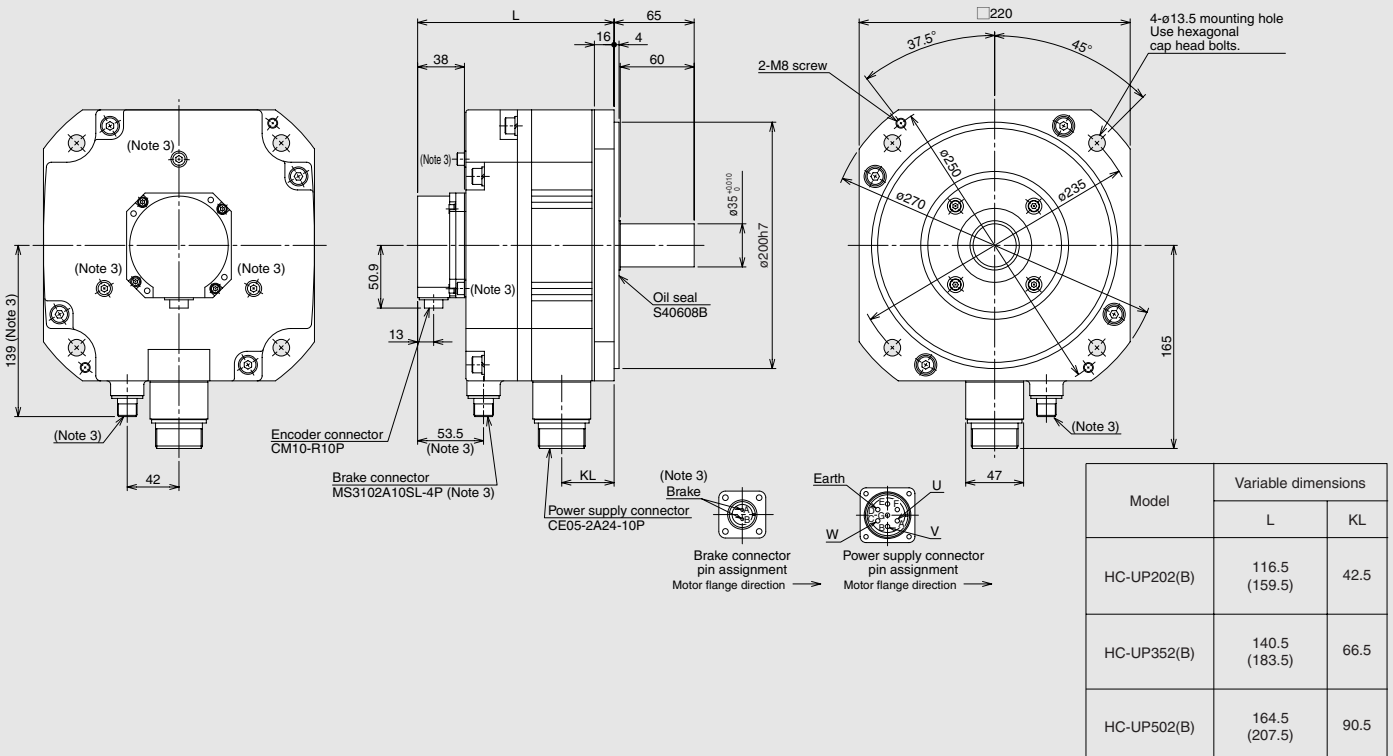

### Notes:

1. Use a friction coupling to fasten a load.
2. Dimensions inside ( ) are for the models with an electromagnetic brake.
3. Only for the models with an electromagnetic brake. The electromagnetic brake terminals do not have polarity.
4. For dimensions where there is no tolerance listed, use general tolerance.

# Motor Dimensions

(Unit: mm)

## ● HA-LP502

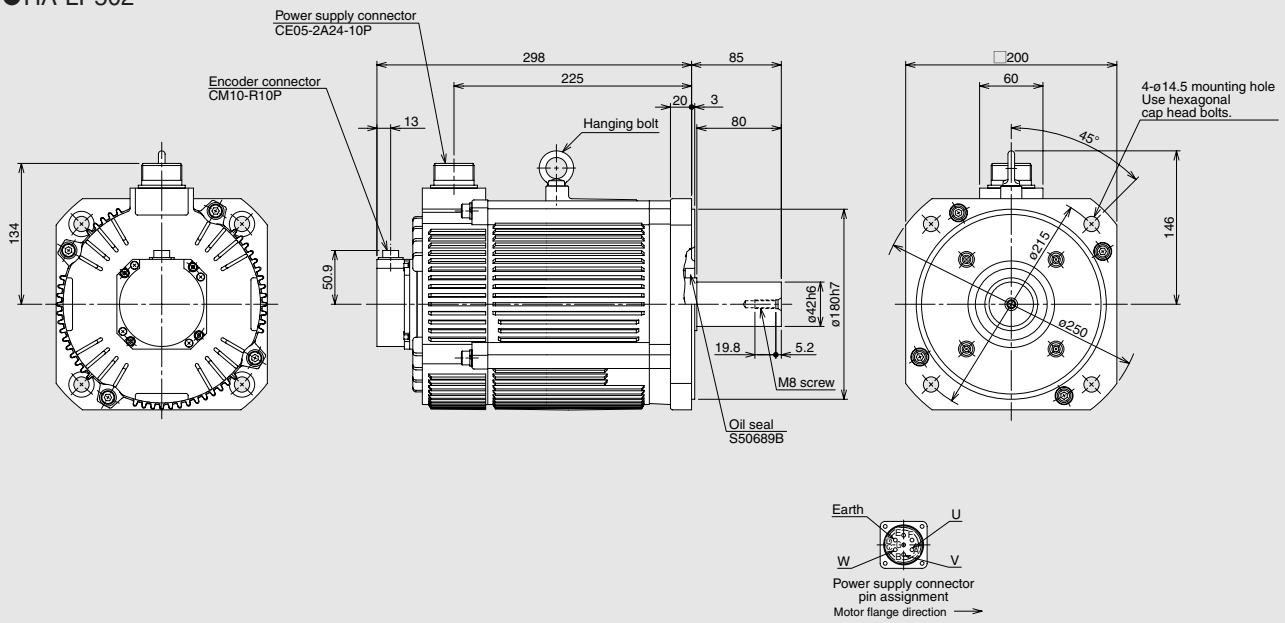

## ● HA-LP702

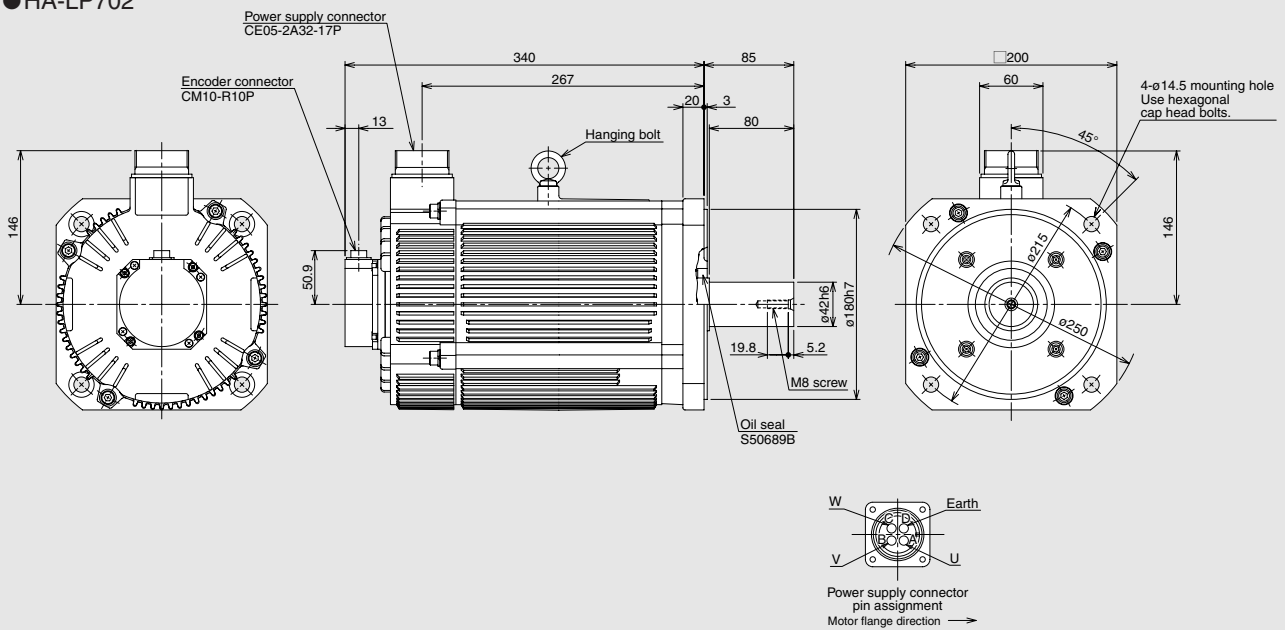

### Notes:

1. Use a friction coupling to fasten a load.
2. For dimensions where there is no tolerance listed, use general tolerance.

# Motor Dimensions

(Unit: mm)

- HA-LP601(B), HA-LP6014(B)
- HA-LP701M(B), HA-LP701M4(B)
- HA-LP11K2(B), HA-LP11K24(B)

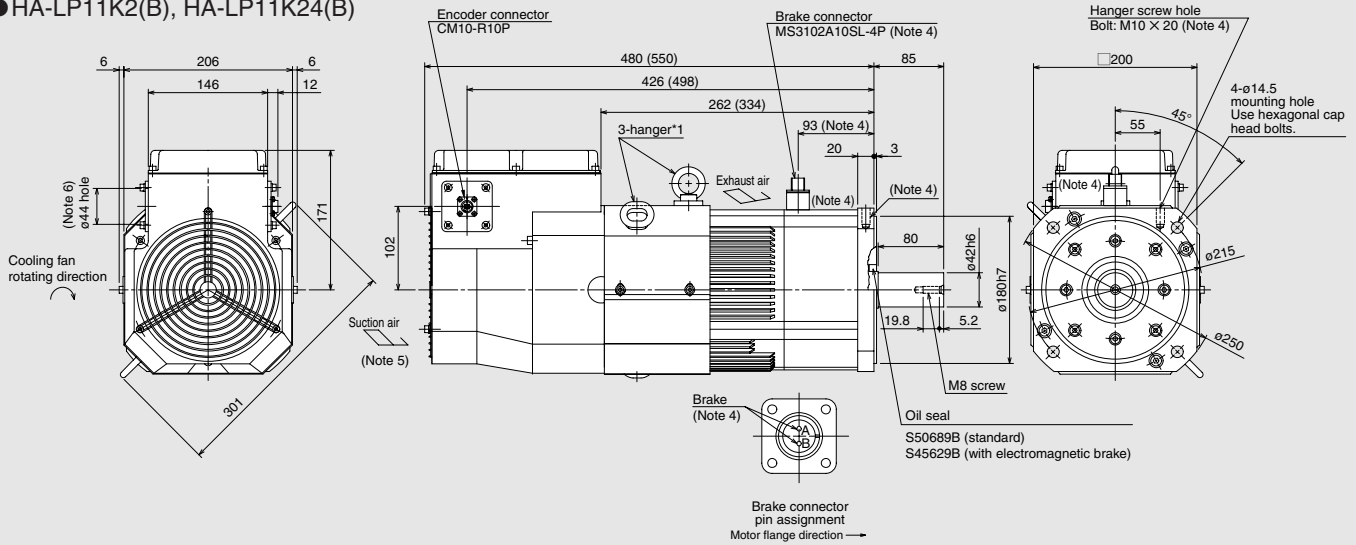

\*1 When using the motor without the hanger, plug the threaded hole with a bolt of M10 × 20 or shorter.

\*2 The terminal block on the terminal box housing consists of M6 screws for the motor power supply (U, V, W), and M4 screws for the cooling fan (BU, BV) and for the thermal protector (OHS1, OHS2).

- HA-LP801(B), HA-LP12K1(B), HA-LP8014(B) (Note 7), HA-LP12K14(B)
- HA-LP11K1M(B), HA-LP15K1M(B), HA-LP11K1M4(B) (Note 7), HA-LP15K1M4(B)
- HA-LP15K2(B), HA-LP22K2(B), HA-LP15K24(B), HA-LP22K24(B)

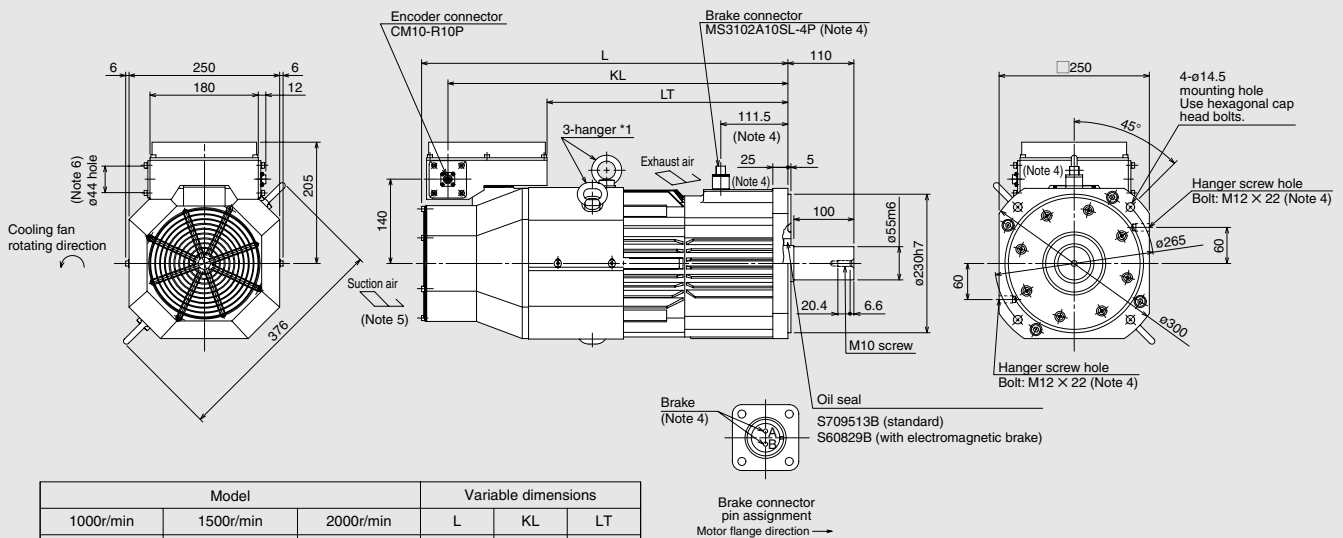

Model			Variable dimensions		
1000r/min	1500r/min	2000r/min	L	KL	LT
HA-LP801(B) HA-LP8014(B)	HA-LP11K1M(B) HA-LP11K1M4(B)	HA-LP15K2(B) HA-LP15K24(B)	495 (610)	454 (565)	289 (400)
HA-LP12K1(B) HA-LP12K14(B)	HA-LP15K1M(B) HA-LP15K1M4(B)	HA-LP22K2(B) HA-LP22K24(B)	555 (670)	511 (622)	346 (457)

\*1 When using the motor without the hanger, plug the threaded hole with a bolt of M12 × 20 or shorter.

\*2 The terminal block on the terminal box housing consists of M8 screws for the motor power supply (U, V, W), and M4 screws for the cooling fan (BU, BV, BW) and for the thermal protector (OHS1, OHS2).

Notes:

1. Use a friction coupling to fasten a load.
2. For dimensions where there is no tolerance listed, use general tolerance.
3. Dimensions inside ( ) are for the models with an electromagnetic brake.
4. Only for the models with an electromagnetic brake. The electromagnetic brake terminals do not have polarity.
5. Leave a clearance of at least 100mm between the motor's suction side and wall.
6. Make sure that oil, water and dust, etc., will not enter the motor from the lead-in hole.
7. Contact your dealer for the delivery schedule or the compatible servo amplifier software version.



# Motor Dimensions

(Unit: mm)

- HA-LP15K1, HA-LP20K1, HA-LP15K14, HA-LP20K14 (Note 7)
- HA-LP22K1M, HA-LP22K1M4 (Note 7), HA-LP30K1M4
- HA-LP30K24, HA-LP37K24

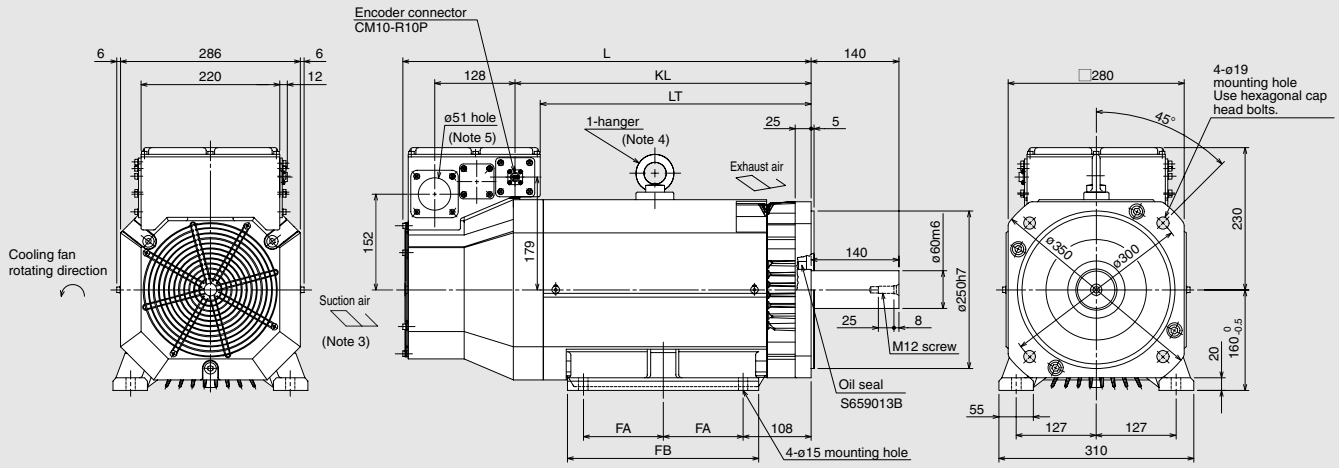

Model			Variable dimensions				
1000r/min	1500r/min	2000r/min	L	KL	LT	FA	FB
HA-LP15K1 HA-LP15K14	HA-LP22K1M HA-LP22K1M4	HA-LP30K24	605	426	386	105	260
HA-LP20K1 HA-LP20K14	HA-LP30K1M4	HA-LP37K24	650	471	431	127	304

\* The terminal block on the terminal box housing consists of M8 screws for the motor power supply (U, V, W), and M4 screws for the cooling fan (BU, BV, BW) and for the thermal protector (OHS1, OHS2).

- HA-LP25K1, HA-LP30K1, HA-LP25K14, HA-LP30K14
- HA-LP37K1M, HA-LP37K1M4, HA-LP45K1M4
- HA-LP45K24, HA-LP55K24

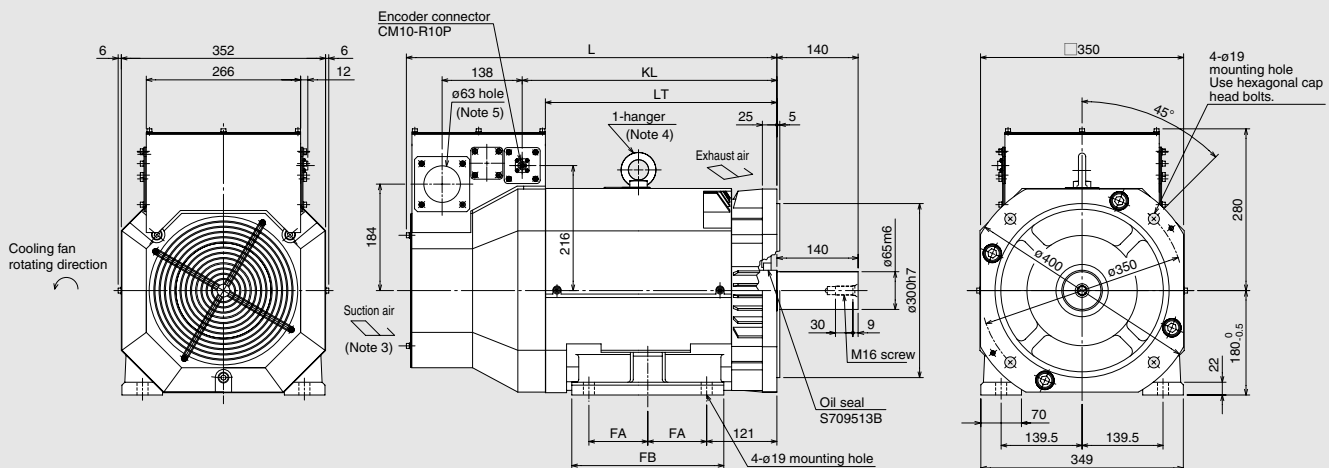

Model			Variable dimensions				
1000r/min	1500r/min	2000r/min	L	LT	KL	FA	FB
HA-LP25K1 HA-LP25K14	HA-LP37K1M HA-LP37K1M4	HA-LP45K24	640	399	439	101.5	262
HA-LP30K1 HA-LP30K14	HA-LP45K1M4	HA-LP55K24	685	444	484	120.5	300

\* The terminal block on the terminal box housing consists of M10 screws for the motor power supply (U, V, W), and M4 screws for the cooling fan (BU, BV, BW) and for the thermal protector (OHS1, OHS2).

**Notes:**

1. Use a friction coupling to fasten a load.
2. For dimensions where there is no tolerance listed, use general tolerance.
3. Leave a clearance of at least 150mm between the motor's suction side and wall.
4. When using the motor without the hanger, plug the threaded hole with a bolt of M16 × 20 or shorter.
5. Make sure that oil, water and dust, etc., will not enter the motor from the lead-in hole.
6. When mounting the motor with the shaft horizontal, fix the motor either with the legs or the flange, keeping the legs downward. Note that when fixing the motor with the flange, also fix the legs to support the motor.
7. Contact your dealer for the delivery schedule or the compatible servo amplifier software version.

# Motor Dimensions

(Unit: mm)

- HA-LP30K1M
- HA-LP30K2, HA-LP37K2

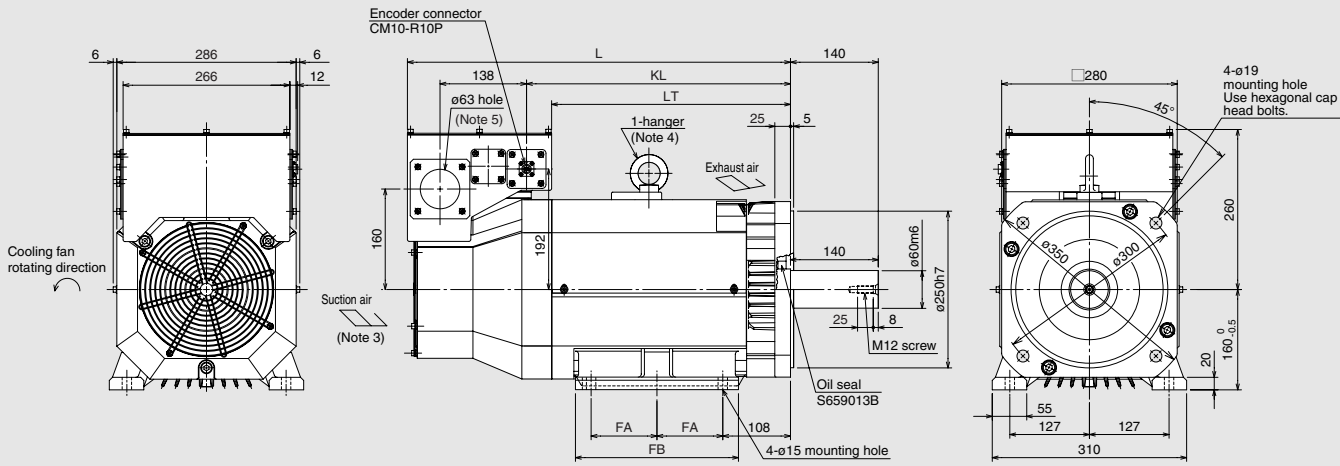

Model		Variable dimensions				
1500r/min	2000r/min	L	LT	KL	FA	FB
-	HA-LP30K2	615	381	421	105	260
HA-LP30K1M	HA-LP37K2	660	426	466	127	304

\* The terminal block on the terminal box housing consists of M10 screws for the motor power supply (U, V, W), and M4 screws for the cooling fan (BU, BV, BW) and for the thermal protector (OHS1, OHS2).

- HA-LP37K1, HA-LP37K14
- HA-LP50K1M4

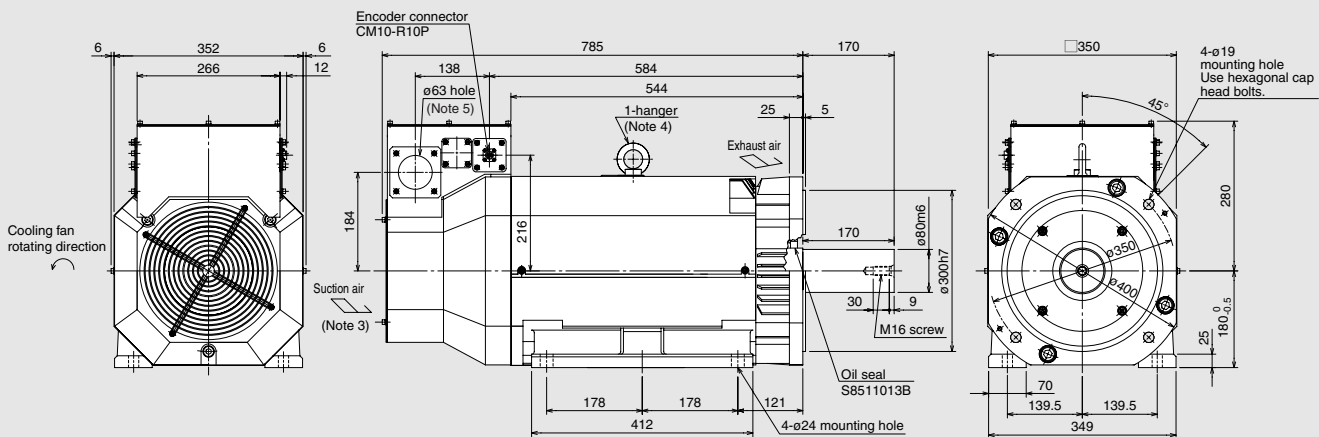

\* The terminal block on the terminal box housing consists of M10 screws for the motor power supply (U, V, W), and M4 screws for the cooling fan (BU, BV, BW) and for the thermal protector (OHS1, OHS2).

## Notes:

1. Use a friction coupling to fasten a load.
2. For dimensions where there is no tolerance listed, use general tolerance.
3. Leave a clearance of at least 150mm between the motor's suction side and wall.
4. When using the motor without the hanger, plug the threaded hole with a bolt of M16 × 20 or shorter.
5. Make sure that oil, water and dust, etc., will not enter the motor from the lead-in hole.
6. When mounting the motor with the shaft horizontal, fix the motor either with the legs or the flange, keeping the legs downward. Note that when fixing the motor with the flange, also fix the legs to support the motor.

# Motor Special Specifications

## Electromagnetic brake specifications (Note 1)

Motor model		HF-KP/HF-MP					HF-SP 1000r/min					
		053B	13B	23B	43B	73B	51B	81B	121B	201B	301B	421B
Type		Spring-action safety brake					Spring-action safety brake					
Rated voltage		24VDC $^{0}_{-10}\%$					24VDC $^{0}_{-10}\%$					
Brake static friction torque	(N-m)	0.32	0.32	1.3	1.3	2.4	8.5	8.5	44	44	44	44
	(oz.in)	45.3	45.3	184	184	340	1200	1200	6230	6230	6230	6230
Power consumption (W) at 20°C (68°F)		6.3	6.3	7.9	7.9	10	20	20	34	34	34	34
Permissible braking work	(J)/time	5.6	5.6	22	22	64	400	400	4500	4500	4500	4500
	(J)/hour	56	56	220	220	640	4000	4000	45000	45000	45000	45000
Brake life (Note 2) (Braking work per braking action)	Times	20000 (5.6J)	20000 (5.6J)	20000 (22J)	20000 (22J)	20000 (64J)	20000 (200J)	20000 (200J)	20000 (1000J)	20000 (1000J)	20000 (1000J)	20000 (1000J)

Motor model		HF-SP 2000r/min					
		52B/524B	102B/1024B	152B/1524B	202B/2024B	352B/3524B	502B/5024B
Type		Spring-action safety brake					
Rated voltage		24VDC $^{0}_{-10}\%$					
Brake static friction torque	(N-m)	8.5	8.5	8.5	44	44	44
	(oz.in)	1200	1200	1200	6230	6230	6230
Power consumption (W) at 20°C (68°F)		20	20	20	34	34	34
Permissible braking work	(J)/time	400	400	400	4500	4500	4500
	(J)/hour	4000	4000	4000	45000	45000	45000
Brake life (Note 2) (Braking work per braking action)	Times	20000 (200J)	20000 (200J)	20000 (200J)	20000 (1000J)	20000 (1000J)	20000 (1000J)

Motor model		HC-LP					HC-RP				
		52B	102B	152B	202B	302B	103B	152B	203B	353B	503B
Type		Spring-action safety brake					Spring-action safety brake				
Rated voltage		24VDC $^{0}_{-10}\%$					24VDC $^{0}_{-10}\%$				
Brake static friction torque	(N-m)	8.5	8.5	8.5	44	44	7	7	7	17	17
	(oz.in)	1200	1200	1200	6230	6230	991	991	991	2410	2410
Power consumption (W) at 20°C (68°F)		19	19	19	34	34	19	19	19	23	23
Permissible braking work	(J)/time	400	400	400	4500	4500	400	400	400	400	400
	(J)/hour	4000	4000	4000	45000	45000	4000	4000	4000	4000	4000
Brake life (Note 2) (Braking work per braking action)	Times	20000 (200J)	20000 (200J)	20000 (200J)	20000 (1000J)	20000 (1000J)	20000 (200J)	20000 (200J)	20000 (200J)	20000 (200J)	20000 (200J)

Motor model		HC-UP					HA-LP 1000r/min		
		72B	152B	202B	352B	502B	601B/6014B	801B/8014B	12K1B/12K14B
Type		Spring-action safety brake					Spring-action safety brake		
Rated voltage		24VDC $^{0}_{-10}\%$					24VDC $^{0}_{-10}\%$		
Brake static friction torque	(N-m)	8.5	8.5	44	44	44	82	160.5	160.5
	(oz.in)	1200	1200	6230	6230	6230	11600	22700	22700
Power consumption (W) at 20°C (68°F)		19	19	34	34	34	30	46	46
Permissible braking work	(J)/time	400	400	4500	4500	4500	3000	5000	5000
	(J)/hour	4000	4000	45000	45000	45000	30000	50000	50000
Brake life (Note 2) (Braking work per braking action)	Times	20000 (200J)	20000 (200J)	20000 (1000J)	20000 (1000J)	20000 (1000J)	20000 (1000J)	20000 (3000J)	20000 (3000J)

Motor model		HA-LP 1500r/min			HA-LP 2000r/min		
		701MB/701M4B	11K1MB/11K1M4B	15K1MB/15K1M4B	11K2B/11K24B	15K2B/15K24B	22K2B/22K24B
Type		Spring-action safety brake			Spring-action safety brake		
Rated voltage		24VDC $^{0}_{-10}\%$			24VDC $^{0}_{-10}\%$		
Brake static friction torque	(N-m)	82	160.5	160.5	82	160.5	160.5
	(oz.in)	11600	22700	22700	11600	22700	22700
Power consumption (W) at 20°C (68°F)		30	46	46	30	46	46
Permissible braking work	(J)/time	3000	5000	5000	3000	5000	5000
	(J)/hour	30000	50000	50000	30000	50000	50000
Brake life (Note 2) (Braking work per braking action)	Times	20000 (1000J)	20000 (3000J)	20000 (3000J)	20000 (1000J)	20000 (3000J)	20000 (3000J)

Notes: 1. The electromagnetic brake is for holding. It cannot be used for deceleration applications.  
2. The brake gap cannot be adjusted. The brake life shows time until the readjustment is needed.

# Motor Special Specifications

## Special shaft end specifications

Motors with the following specifications are available.

### HF-KP/HF-MP series

#### ● D-cut shaft (Note 1) (50, 100W)

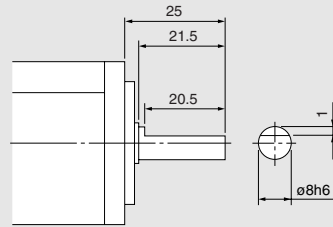

(Unit: mm)

#### ● Keyway shaft with key (Note 1) (200, 400, 750W)

Motor model	Capacity (W)	Variable dimensions								Y
		T	S	R	Q	W	QK	QL	U	
HF-KP□K HF-MP□K	200, 400	5	14h6	30	27	5	20	3	3	M4 screw Depth: 15mm
	750	6	19h6	40	37	6	25	5	3.5	M5 screw Depth: 20mm

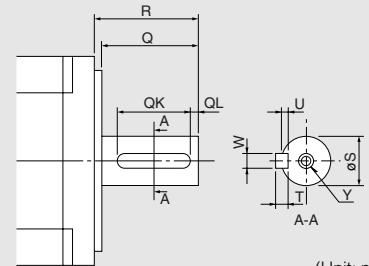

(Unit: mm)

### HF-SP, HC-LP, HC-RP, HC-UP, HA-LP series

#### ● Keyway shaft without key (Note 1, 2)

Motor model	Capacity (kW)	Variable dimensions									Fig.
		S	R	Q	W	QK	QL	U	r	Y	
HF-SP□K HC-LP□K (Note 3)	0.5 to 1.5	24h6	55	50	8 <sup>0</sup> <sub>-0.036</sub>	36	5	4 <sup>+0.2</sup> <sub>0</sub>	4	M8 screw Depth: 20mm	A
	2.0 to 7.0	35 <sup>+0.01</sup> <sub>0</sub>	79	75	10 <sup>0</sup> <sub>-0.036</sub>	55	5	5 <sup>+0.2</sup> <sub>0</sub>	5		
HC-RP□K	1.0, 1.5, 2.0	24h6	45	40	8 <sup>0</sup> <sub>-0.036</sub>	25	5	4 <sup>+0.2</sup> <sub>0</sub>	4	M8 screw Depth: 20mm	A
	3.5, 5.0	28h6	63	58	8 <sup>0</sup> <sub>-0.036</sub>	53	3	4 <sup>+0.2</sup> <sub>0</sub>	4		
HC-UP□K	0.75	22h6	55	50	6 <sup>0</sup> <sub>-0.036</sub>	42	3	3.5 <sup>+0.1</sup> <sub>0</sub>	3	M8 screw Depth: 20mm	A
	1.5	28h6	55	50	8 <sup>0</sup> <sub>-0.036</sub>	53	3	4 <sup>+0.2</sup> <sub>0</sub>	4		
	2.0, 3.5, 5.0	35 <sup>+0.01</sup> <sub>0</sub>	65	60	10 <sup>0</sup> <sub>-0.036</sub>	50	5	5 <sup>+0.2</sup> <sub>0</sub>	5		

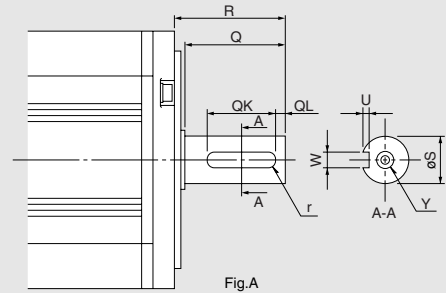

Fig.A

Motor model (HA-LP□K)	Variable dimensions									Fig.
	S	R	Q	W	QK	QL	U	r	Y	
601, 6014, 701M, 701M4, 502, 702, 11K2, 11K24	42h6	85	80	12 <sup>0</sup> <sub>-0.04</sub>	70	5	5 <sup>+0.2</sup> <sub>0</sub>	6	Same as standard motor's straight shaft.	A
801, 12K1, 8014, 12K14, 11K1M, 15K1M, 11K1M4, 15K1M4, 15K2, 22K2, 15K24, 22K24	55m6	110	100	16 <sup>0</sup> <sub>-0.04</sub>	90	5	6 <sup>+0.2</sup> <sub>0</sub>	8		
15K1, 20K1, 15K14, 20K14, 22K1M, 30K1M, 22K1M4, 30K1M4, 30K2, 37K2, 30K24, 37K24	60m6	140	140	18 <sup>0</sup> <sub>-0.04</sub>	128	6	7 <sup>+0.2</sup> <sub>0</sub>	9	Same as standard motor's straight shaft.	B
25K1, 30K1, 25K14, 30K14, 37K1M, 37K1M4, 45K1M4, 45K24, 55K24	65m6	140	140	18 <sup>0</sup> <sub>-0.04</sub>	128	6	7 <sup>+0.2</sup> <sub>0</sub>	9		
37K1, 37K14, 50K1M4	80m6	170	170	22 <sup>0</sup> <sub>-0.04</sub>	147	11	9 <sup>+0.2</sup> <sub>0</sub>	11		

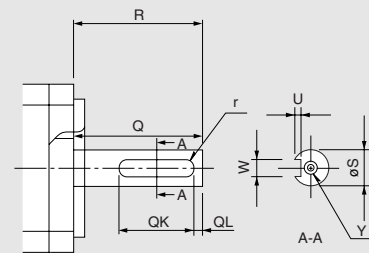

Fig.B

(Unit: mm)

Notes: 1. The motors with the keyway shaft (with/without key) and the D-cut shaft cannot be used in frequent start/stop applications.  
2. A key is not supplied with the motor. The key shall be installed by the user.  
3. For HF-SP121K, the variable dimensions are same as the lower row, 2.0 to 7.0kW.

# Peripheral Equipment (MR-J3-A)

## Connections with peripheral equipment (Note 1)

Peripheral equipment is connected to MR-J3-A as described below.

Connectors, options, and other necessary equipment are available so that users can set up MR-J3-A easily and begin using it right away.

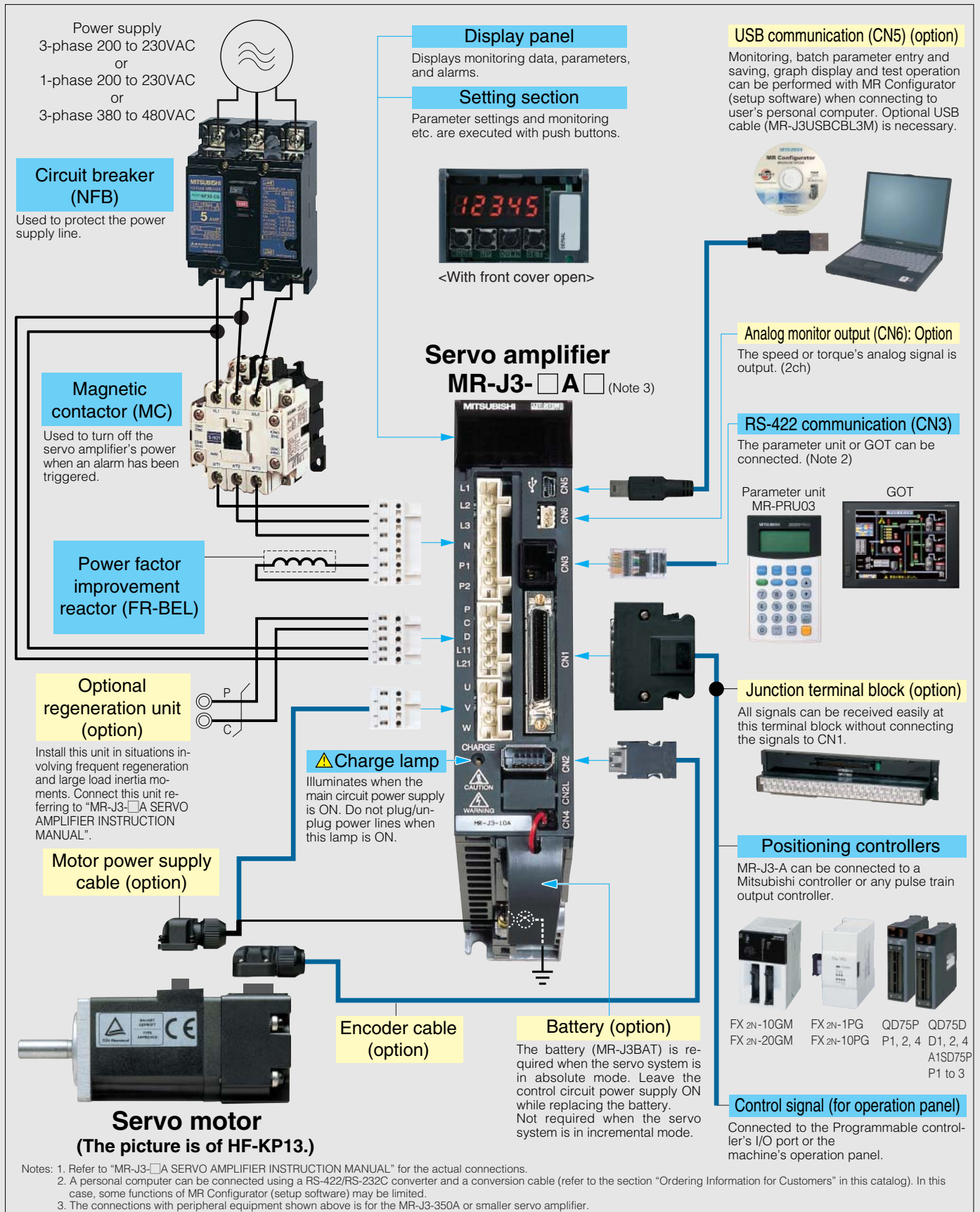

# Amplifier Specifications

## MR-J3-A servo amplifier specifications: 100VAC/200VAC, 22kW or smaller

Servo amplifier model MR-J3-		10A	20A	40A	60A	70A	100A	200A	350A	500A	700A	11KA	15KA	22KA	10A1	20A1	40A1
Main circuit power supply	Voltage/frequency (Note 1, 2)	3-phase 200 to 230VAC 50/60Hz or 1-phase 200 to 230VAC 50/60Hz (Note 10)					3-phase 200 to 230VAC 50/60Hz							1-phase 100 to 120VAC 50/60Hz			
	Permissible voltage fluctuation	For 3-phase 200 to 230VAC: 3-phase 170 to 253VAC For 1-phase 200 to 230VAC: 1-phase 170 to 253VAC					3-phase 170 to 253VAC							1-phase 85 to 132VAC			
	Permissible frequency fluctuation	±5% maximum															
Control circuit power supply	Voltage/frequency	1-phase 200 to 230VAC 50/60Hz (Note 10)					1-phase 200 to 230VAC 50/60Hz							1-phase 100 to 120VAC 50/60Hz			
	Permissible voltage fluctuation	1-phase 170 to 253VAC															
	Permissible frequency fluctuation	±5% maximum															
	Power consumption (W)	30					45					30					
Interface power supply		24VDC ±10% (required current capacity: 300mA (Note 7))															
Regenerative resistor/ tolerable regenerative power (W) (Note 3, 4)	Built-in regenerative resistor	—	10	10	10	20	20	100	100	130	170	—	—	—	—	10	10
	External regenerative resistor (Standard accessory) (Note 5, 6)	—	—	—	—	—	—	—	—	—	—	500 (800)	850 (1300)	850 (1300)	—	—	—
Control system		Sine-wave PWM control/current control system															
Dynamic brake		Built-in (Note 8)										External option			Built-in (Note 8)		
Safety features		Overcurrent shutdown, regeneration overvoltage shutdown, overload shutdown (electronic thermal), servo motor overheat protection, encoder fault protection, regeneration fault protection, undervoltage/sudden power outage protection, overspeed protection, excess error protection															
Position control mode	Maximum input pulse frequency	1Mpps (when using differential receiver), 200kpps (when using open collector), (4Mpps (Note 11))															
	Positioning feedback pulse	Resolution per encoder/servo motor rotation: 262144 p/rev															
	Command pulse multiple	Electronic gear A/B multiple, A: 1 to 1048576, B: 1 to 1048576, 1/10 < A/B < 2000															
	Positioning complete width setting	0 to ±10000 pulses (command pulse unit)															
	Excess error	±3 rotations															
Speed control mode	Torque limit	Set by parameters or external analog input (0 to +10VDC/maximum torque)															
	Speed control range	Analog speed command 1:2000, internal speed command 1:5000															
	Analog speed command input	0 to ±10VDC/rated speed (possible to change the speed in 10V using the parameter No. PC12.) (Note 12)															
	Speed fluctuation rate	±0.01% maximum (load fluctuation 0 to 100%) 0% (power fluctuation ±10%) ±0.2% maximum (ambient temperature 25°C±10°C (77°F±50°F)), when using analog speed command															
Torque control mode	Torque limit	Set by parameters or external analog input (0 to +10VDC/maximum torque) (Note 12)															
	Speed limit	Set by parameters or external analog input (0 to ±10VDC/rated speed)															
Structure		Self-cooling open (IP00)					Fan cooling open (IP00)							Self-cooling open (IP00)			
Environment	Ambient temperature (Note 6)	0 to 55°C (32 to 131°F) (non freezing), storage: -20 to 65°C (-4 to 149°F) (non freezing)															
	Ambient humidity	90% RH maximum (non condensing), storage: 90% RH maximum (non condensing)															
	Atmosphere	Indoors (no direct sunlight); no corrosive gas, inflammable gas, oil mist or dust															
	Elevation	1000m or less above sea level															
	Vibration	5.9m/s <sup>2</sup> maximum															
Mass (kg [lb])		0.8 (1.8)	0.8 (1.8)	1.0 (2.2)	1.0 (2.2)	1.4 (3.1)	1.4 (3.1)	2.3 (5.1)	2.3 (5.1)	4.6 (10)	6.2 (14)	18 (40)	18 (40)	19 (42)	0.8 (1.8)	0.8 (1.8)	1.0 (2.2)

Notes: 1. Rated output and rated speed of the servo motor used in combination with the servo amplifier are as indicated when using the power supply voltage and frequency listed. The torque drops when the power supply voltage is less than specified.

2. For torque characteristics when combined with a servo motor, refer to the section "Servo motor torque characteristics" in this catalog.

3. Optimal regenerative resistor varies for each system. Select the most suitable regenerative resistor by using the capacity selection software.

4. Refer to the section "Options ● Optional regeneration unit" in this catalog for the tolerable regenerative power (W).

5. The servo amplifier (MR-J3-□KA-PX) without an enclosed regenerative resistor is also available.

6. The value applies when the external regenerative resistors, GRZG400-□□, (standard accessory) are used with cooling fans (2 units of 92 X 92mm, minimum air flow: 1.0m<sup>3</sup>/min). Note that change in the parameter No. PA02 is required.

7. 300mA is the value when all of the input/output points are used. The current capacity can be stepped down according to the number of input/output points in use. Refer to "MR-J3-□A SERVO AMPLIFIER INSTRUCTION MANUAL" for details.

8. Special specification models without a dynamic brake, MR-J3-□A-ED and MR-J3-□A1-ED, are also available.

9. The MR-J3-350A or smaller servo amplifier can be installed closely. In this case, keep the ambient temperature within 0 to 45°C (32 to 113°F), or use the servo amplifier with 75% or less of the effective load rate.

10. The special specification model, MR-J3-□A-U004, is also available for 1-phase 200 to 240 VAC.

11. 4Mpps compatible servo amplifier (MR-J3-□A(1)-KE) is also available.

12. A set of MR-J3-□A(1)-RJ040 and the extension IO unit, MR-J3-D01, is available for high resolution analog speed torque command.

## MR-J3-A servo amplifier specifications: 200VAC, 30kW or larger

		Drive unit model	MR-J3-DU30KA	MR-J3-DU37KA
Drive unit	Main circuit power supply	Voltage/frequency (Note 1)	The drive unit's main circuit power is supplied from the converter unit.	
		Permissible voltage fluctuation		
		Permissible frequency fluctuation		
	Control circuit power supply	Voltage/frequency	1-phase 200 to 230VAC 50/60Hz	
		Permissible voltage fluctuation	1-phase 170 to 253VAC	
		Permissible frequency fluctuation	±5% maximum	
		Power consumption (W)	45	
	Interface power supply		24VDC ±10% (required current capacity: 300mA (Note 3))	
	Control system		Sine-wave PWM control/current control system	
	Dynamic brake		External option	
	Safety features		Overcurrent shutdown, overload shutdown (electronic thermal), servo motor overheat protection, encoder fault protection, undervoltage/sudden power outage protection, overspeed protection, excess error protection	
	Position control mode	Maximum input pulse frequency	1Mpps (when using differential receiver), 200kpps (when using open collector)	
		Positioning feedback pulse	Resolution per encoder/servo motor rotation: 262144 p/rev	
		Command pulse multiple	Electronic gear A/B multiple, A: 1 to 1048576, B: 1 to 1048576, 1/10 < A/B < 2000	
		Positioning complete width setting	0 to ±10000 pulses (command pulse unit)	
		Excess error	±3 rotations	
	Speed control mode	Torque limit	Set by parameters or external analog input (0 to +10VDC/maximum torque)	
		Speed control range	Analog speed command 1:2000, internal speed command 1:5000	
		Analog speed command input	0 to ±10VDC/rated speed (possible to change the speed in 10V using the parameter No. PC12.)	
Speed fluctuation rate		±0.01% maximum (load fluctuation 0 to 100%) 0% (power fluctuation ±10%) ±0.2% maximum (ambient temperature 25°C±10°C (77°F±50°F)), when using analog speed command		
Torque control mode	Torque limit	Set by parameters or external analog input (0 to +10VDC/maximum torque)		
	Analog torque command input	0 to ±8VDC/maximum torque (input impedance 10 to 12kΩ)		
Torque control mode	Speed limit	Set by parameters or external analog input (0 to ±10VDC/rated speed)		
	Structure	Fan cooling open (IP00)		
Mass (kg [lb])		26 (57)		
Converter unit	Converter unit model		MR-J3-CR55K	
	Main circuit power supply	Voltage/frequency (Note 1, 2)	3-phase 200 to 230VAC 50/60Hz	
		Permissible voltage fluctuation	3-phase 170 to 253VAC	
		Permissible frequency fluctuation	±5% maximum	
	Control circuit power supply	Voltage/frequency	1-phase 200 to 230VAC 50/60Hz	
		Permissible voltage fluctuation	1-phase 170 to 253VAC	
		Permissible frequency fluctuation	±5% maximum	
		Power consumption (W)	45	
	Interface power supply		24VDC ±10% (required current capacity: 130mA (Note 3))	
	Safety features		Regeneration overvoltage shutdown, regeneration fault protection, overload shutdown (electronic thermal), undervoltage/sudden power outage protection	
	Structure		Fan cooling open (IP00)	
Mass (kg [lb])		25 (55)		
Drive unit/ Converter unit	Environment	Ambient temperature	0 to 55°C (32 to 131°F) (non freezing), storage: -20 to 65°C (-4 to 149°F) (non freezing)	
		Ambient humidity	90% RH maximum (non condensing), storage: 90% RH maximum (non condensing)	
		Atmosphere	Indoors (no direct sunlight); no corrosive gas, inflammable gas, oil mist or dust	
		Elevation	1000m or less above sea level	
		Vibration	5.9m/s <sup>2</sup> maximum	

- Notes: 1. Rated output and rated speed of the servo motor used in combination with the drive unit and the converter unit are as indicated when using the power supply voltage and frequency listed. The torque drops when the power supply voltage is less than specified.  
2. For torque characteristics when combined with a servo motor, refer to the section "Servo motor torque characteristics" in this catalog.  
3. The interface power supply can be shared with the drive unit and the converter unit. When all of the input/output points are used, 300mA is required for the drive unit, and 130mA is required for the converter unit. The current capacity can be stepped down according to the number of input/output points in use. Refer to "MR-J3-□A SERVO AMPLIFIER INSTRUCTION MANUAL" for details.

# Amplifier Specifications

## MR-J3-A servo amplifier specifications: 400VAC, 22kW or smaller

Servo amplifier model MR-J3-		60A4	100A4	200A4	350A4	500A4	700A4	11KA4	15KA4	22KA4
Main circuit power supply	Voltage/frequency (Note 1, 2)	3-phase 380 to 480VAC 50/60Hz								
	Permissible voltage fluctuation	3-phase 323 to 528VAC								
	Permissible frequency fluctuation	±5% maximum								
Control circuit power supply	Voltage/frequency	1-phase 380 to 480VAC 50/60Hz								
	Permissible voltage fluctuation	1-phase 323 to 528VAC								
	Permissible frequency fluctuation	±5% maximum								
Power consumption (W)		30			45					
Interface power supply		24VDC ±10% (required current capacity: 300mA (Note 7))								
Regenerative resistor/ tolerable regenerative power (W) (Note 3, 4)	Built-in regenerative resistor	15	15	100	100	130 (Note 9)	170 (Note 9)	—	—	—
	External regenerative resistor (Standard accessory) (Note 5, 6)	—	—	—	—	—	—	500 (800)	850 (1300)	850 (1300)
Control system		Sine-wave PWM control/current control system								
Dynamic brake		Built-in (Note 8, 10)						External option		
Safety features		Overcurrent shutdown, regeneration overvoltage shutdown, overload shutdown (electronic thermal), servo motor overheat protection, encoder fault protection, regeneration fault protection, undervoltage/sudden power outage protection, overspeed protection, excess error protection								
Position control mode	Maximum input pulse frequency	1Mpps (when using differential receiver), 200kpps (when using open collector)								
	Positioning feedback pulse	Resolution per encoder/servo motor rotation: 262144 p/rev								
	Command pulse multiple	Electronic gear A/B multiple, A: 1 to 1048576, B: 1 to 1048576, 1/10 < A/B < 2000								
	Positioning complete width setting	0 to ±10000 pulses (command pulse unit)								
	Excess error	±3 rotations								
	Torque limit	Set by parameters or external analog input (0 to +10VDC/maximum torque)								
Speed control mode	Speed control range	Analog speed command 1:2000, internal speed command 1:5000								
	Analog speed command input	0 to ±10VDC/rated speed (possible to change the speed in 10V using the parameter No. PC12.) (Note 11)								
	Speed fluctuation rate	±0.01% maximum (load fluctuation 0 to 100%) 0% (power fluctuation ±10%) ±0.2% maximum (ambient temperature 25°C±10°C (77°F±50°F)), when using analog speed command								
	Torque limit	Set by parameters or external analog input (0 to +10VDC/maximum torque) (Note 11)								
Torque control mode	Analog torque command input	0 to ±8VDC/maximum torque (input impedance 10 to 12kΩ) (Note 11)								
	Speed limit	Set by parameters or external analog input (0 to ±10VDC/rated speed)								
Structure		Self-cooling open (IP00)			Fan cooling open (IP00)					
Environment	Ambient temperature (Note 6)	0 to 55°C (32 to 131°F) (non freezing), storage: -20 to 65°C (-4 to 149°F) (non freezing)								
	Ambient humidity	90% RH maximum (non condensing), storage: 90% RH maximum (non condensing)								
	Atmosphere	Indoors (no direct sunlight); no corrosive gas, inflammable gas, oil mist or dust								
	Elevation	1000m or less above sea level								
	Vibration	5.9m/s <sup>2</sup> maximum								
Mass (kg [lb])		1.7 (3.7)	1.7 (3.7)	2.1 (4.6)	4.6 (10)	4.6 (10)	6.2 (14)	18 (40)	18 (40)	19 (42)

- Notes: 1. Rated output and rated speed of the servo motor used in combination with the servo amplifier are as indicated when using the power supply voltage and frequency listed. The torque drops when the power supply voltage is less than specified.
2. For torque characteristics when combined with a servo motor, refer to the section "Servo motor torque characteristics" in this catalog.
3. Optimal regenerative resistor varies for each system. Select the most suitable regenerative resistor by using the capacity selection software.
4. Refer to the section "Options ● Optional regeneration unit" in this catalog for the tolerable regenerative power (W).
5. The servo amplifier (MR-J3-□KA4-PX) without an enclosed regenerative resistor is also available.
6. The value applies when the external regenerative resistors, GRZG400-□Ω, (standard accessory) are used with cooling fans (2 units of 92 X 92mm, minimum air flow: 1.0m<sup>3</sup>/min). Note that change in the parameter No. PA02 is required.
7. 300mA is the value when all of the input/output points are used. The current capacity can be stepped down according to the number of input/output points in use. Refer to "MR-J3-□A SERVO AMPLIFIER INSTRUCTION MANUAL" for details.
8. Special specification models without a dynamic brake, MR-J3-□A4 -ED, are also available.
9. The amplifier built-in resistor is compatible with the maximum torque deceleration when the motor is used within the rated speed and the recommended load/motor inertia moment ratio. Contact Mitsubishi if the operating motor speed and the load/motor inertia moment ratio exceed the rated speed and the recommended ratio.
10. For the servo amplifier 5kW or 7kW, the load/motor of inertia moment ratio must be 5 times or less when the amplifier built-in dynamic brake is used, and the motor speed exceeds 2000r/min.
11. For the servo amplifier 11kW to 22kW, a set of MR-J3-□A4-RJ040 and the extension IO unit, MR-J3-D01, is available for high resolution analog speed torque command. Servo amplifier 7kW or smaller, compatible with high resolution analog speed torque command, will be available.



## MR-J3-A servo amplifier specifications: 400VAC, 30kW or larger

		Drive unit model	MR-J3-DU30KA4	MR-J3-DU37KA4	MR-J3-DU45KA4	MR-J3-55KA4
Drive unit	Main circuit power supply	Voltage/frequency (Note 1)	The drive unit's main circuit power is supplied from the converter unit.			
		Permissible voltage fluctuation				
		Permissible frequency fluctuation				
	Control circuit power supply	Voltage/frequency	1-phase 380 to 480VAC 50/60Hz			
		Permissible voltage fluctuation	1-phase 323 to 528VAC			
		Permissible frequency fluctuation	±5% maximum			
		Power consumption (W)	45			
	Interface power supply		24VDC ±10% (required current capacity: 300mA (Note 3))			
	Control system		Sine-wave PWM control/current control system			
	Dynamic brake		External option			
	Safety features		Overcurrent shutdown, overload shutdown (electronic thermal), servo motor overheat protection, encoder fault protection, undervoltage/sudden power outage protection, overspeed protection, excess error protection			
	Position control mode	Maximum input pulse frequency	1Mpps (when using differential receiver), 200kpps (when using open collector)			
		Positioning feedback pulse	Resolution per encoder/servo motor rotation: 262144 p/rev			
		Command pulse multiple	Electronic gear A/B multiple, A: 1 to 1048576, B: 1 to 1048576 1/10 < A/B < 2000			
		Positioning complete width setting	0 to ±10000 pulses (command pulse unit)			
		Excess error	±3 rotations			
	Speed control mode	Torque limit	Set by parameters or external analog input (0 to +10VDC/maximum torque)			
		Speed control range	Analog speed command 1:2000, internal speed command 1:5000			
		Analog speed command input	0 to ±10VDC/rated speed (possible to change the speed in 10V using the parameter No. PC12.)			
		Speed fluctuation rate	±0.01% maximum (load fluctuation 0 to 100%) 0% (power fluctuation ±10%) ±0.2% maximum (ambient temperature 25°C±10°C (77°F±50°F)), when using analog speed command			
Torque control mode	Torque limit	Set by parameters or external analog input (0 to +10VDC/maximum torque)				
	Analog torque command input	0 to ±8VDC/maximum torque (input impedance 10 to 12kΩ)				
Torque control mode	Speed limit	Set by parameters or external analog input (0 to ±10VDC/rated speed)				
	Structure	Fan cooling open (IP00)				
Mass (kg [lb])		18 (40)		26 (57)		
Converter unit	Converter unit model		MR-J3-CR55K4			
	Main circuit power supply	Voltage/frequency (Note 1, 2)	3-phase 380 to 480VAC 50/60Hz			
		Permissible voltage fluctuation	3-phase 323 to 528VAC			
		Permissible frequency fluctuation	±5% maximum			
	Control circuit power supply	Voltage/frequency	1-phase 380 to 480VAC 50/60Hz			
		Permissible voltage fluctuation	1-phase 323 to 528VAC			
		Permissible frequency fluctuation	±5% maximum			
		Power consumption (W)	45			
	Interface power supply		24VDC ±10% (required current capacity: 130mA (Note 3))			
	Safety features		Regeneration overvoltage shutdown, regeneration fault protection, overload shutdown (electronic thermal), undervoltage/sudden power outage protection			
Structure		Fan cooling open (IP00)				
Mass (kg [lb])		25 (55)				
Drive unit/ Converter unit	Environment	Ambient temperature	0 to 55°C (32 to 131°F) (non freezing), storage: -20 to 65°C (-4 to 149°F) (non freezing)			
		Ambient humidity	90% RH maximum (non condensing), storage: 90% RH maximum (non condensing)			
		Atmosphere	Indoors (no direct sunlight); no corrosive gas, inflammable gas, oil mist or dust			
		Elevation	1000m or less above sea level			
		Vibration	5.9m/s <sup>2</sup> maximum			

Notes: 1. Rated output and rated speed of the servo motor used in combination with the drive unit and the converter unit are as indicated when using the power supply voltage and frequency listed. The torque drops when the power supply voltage is less than specified.  
 2. For torque characteristics when combined with a servo motor, refer to the section "Servo motor torque characteristics" in this catalog.  
 3. The interface power supply can be shared with the drive unit and the converter unit. When all of the input/output points are used, 300mA is required for the drive unit, and 130mA is required for the converter unit. The current capacity can be stepped down according to the number of input/output points in use. Refer to "MR-J3-□A SERVO AMPLIFIER INSTRUCTION MANUAL" for details.

# Standard Wiring Diagram

## MR-J3-□A□: Position control operation

### ● Connection example to QD75D (position servo, incremental)

#### Main circuit/control circuit power supply connection

The connection differs according to the power voltage.  
→Refer to the main circuit/control circuit power supply connection examples (1) to (6).

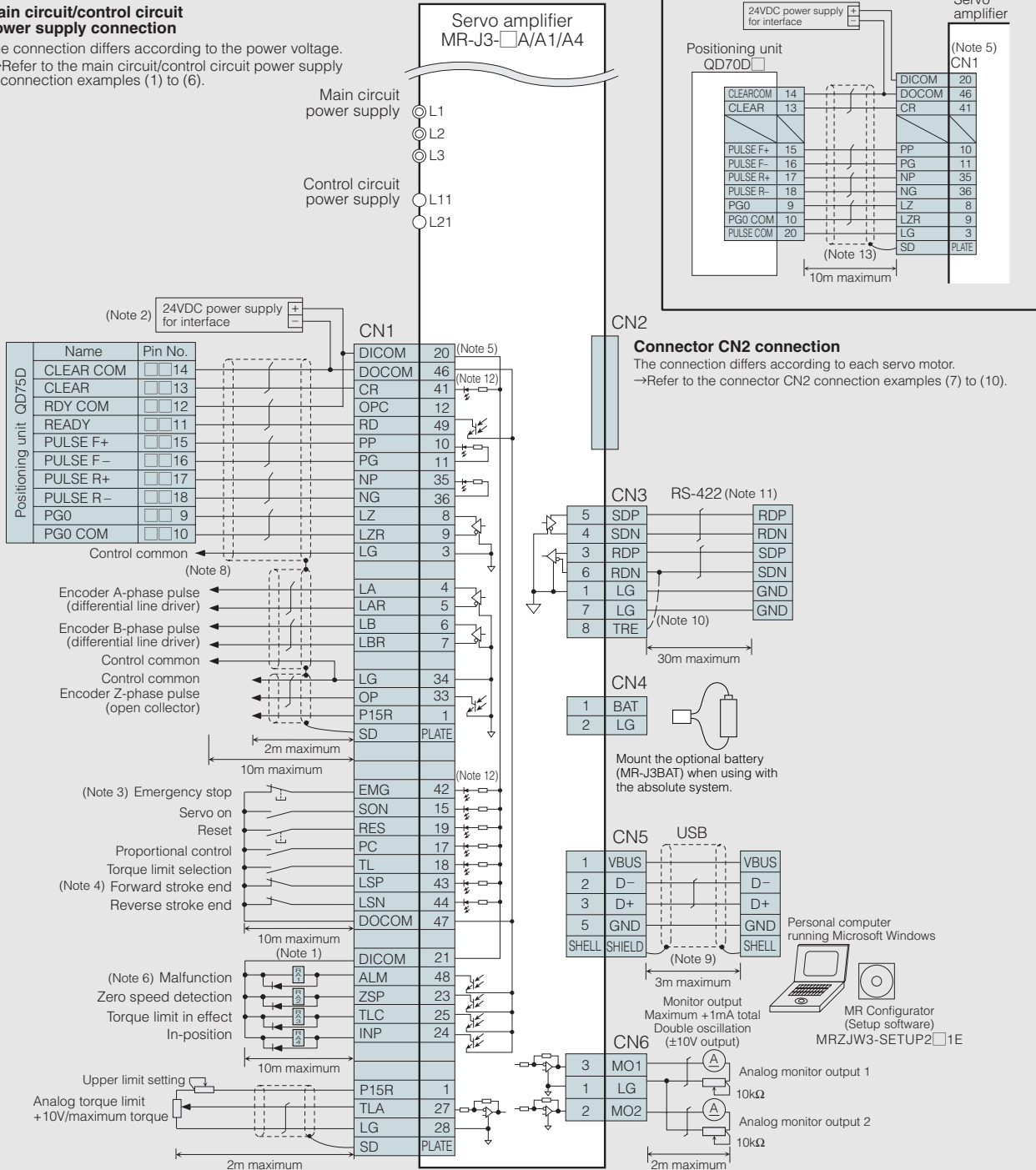

#### Notes:

- Do not reverse the diode's direction. Connecting it backwards could cause the servo amplifier to malfunction such that the signals are not output, and the emergency stop and other safety circuits are inoperable.
- Use the power supply 24VDC±10% (required current capacity: 300mA). 300mA is the value when all of the input/output points are used. Note that the current capacity can be stepped down according to the number of input/output points in use. Refer to "MR-J3-□A SERVO AMPLIFIER INSTRUCTION MANUAL" for details.
- Always turn on the emergency stop (EMG) signal (normally closed contact) before starting the operation. If not, the operation will not start.
- Always turn on the forward/reverse stroke end (LSP/LSN) signals (normally closed contact) before starting the operation. If not, the commands will not be accepted.
- Signals with the same name are connected internally.
- The malfunction (ALM) signal is conducted to DOCOM in normal alarm-free condition.
- Connect the shield wire securely to the plate inside the connector (ground plate).
- This connection is not necessary for QD75D of the positioning unit. Note that the connection between LG and the control common terminal is recommended to increase noise resistance, depending on the positioning unit being used.
- The cable length up to 3m is possible in a low noise environment.
- For the final axis, connect TRE and RDN.
- A personal computer can also be connected using the RS-422/RS-232C conversion cable (refer to the section "Ordering Information for Customers" in this catalog).
- This is for sink wiring. Source wiring is also possible. Refer to "MR-J3-□A SERVO AMPLIFIER INSTRUCTION MANUAL" for details.
- FA goods (Model: FA-CBLQ75M2J3(-P)-1(P)) cannot be used.
- Do not use the connector CN2L.

## MR-J3-□A□: Speed control operation

### ● Connection example

#### Main circuit/control circuit power supply connection

The connection differs according to the power voltage.  
 →Refer to the main circuit/control circuit power supply connection examples (1) to (6).

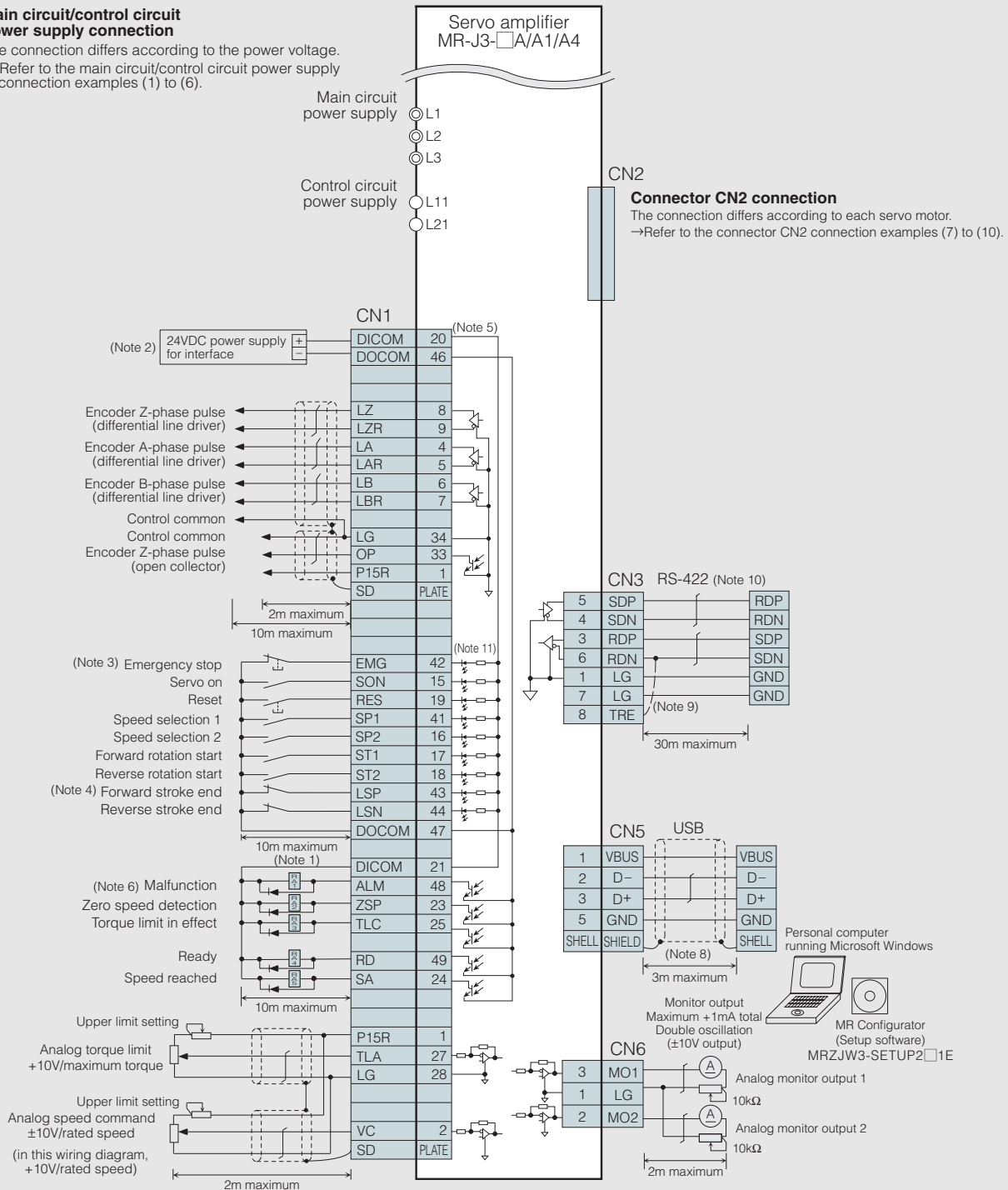

# Standard Wiring Diagram

## MR-J3-□A□: Torque control operation

### ● Connection example

#### Main circuit/control circuit power supply connection

The connection differs according to the power voltage.  
→Refer to the main circuit/control circuit power supply connection examples (1) to (6).

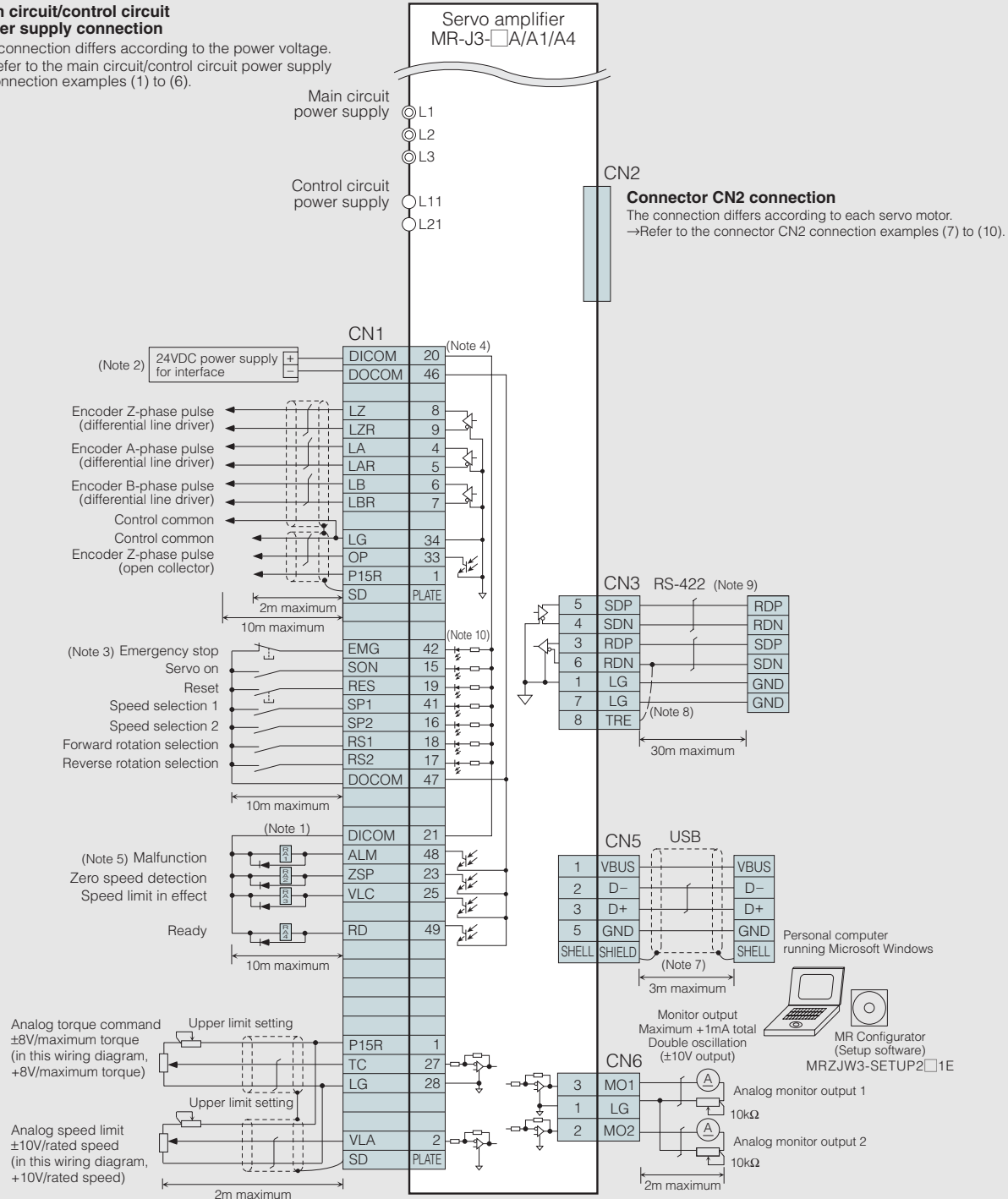

## Main circuit/control circuit power supply connection examples

(1) 1-phase 100V

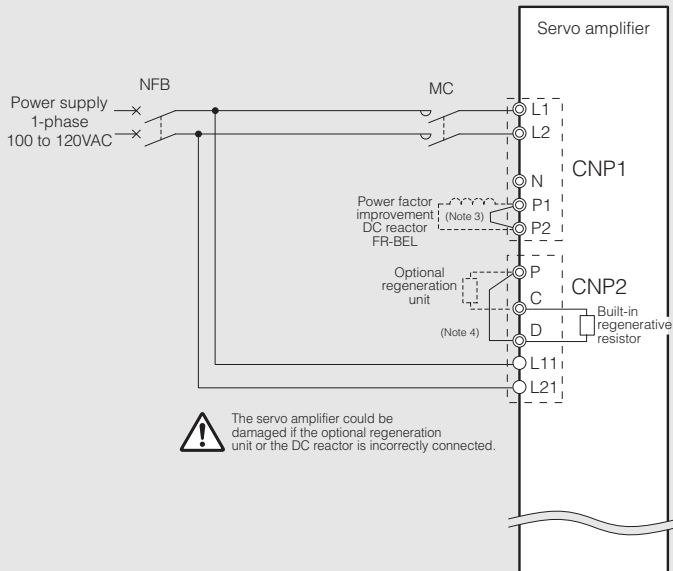

(2) 1-phase 200V

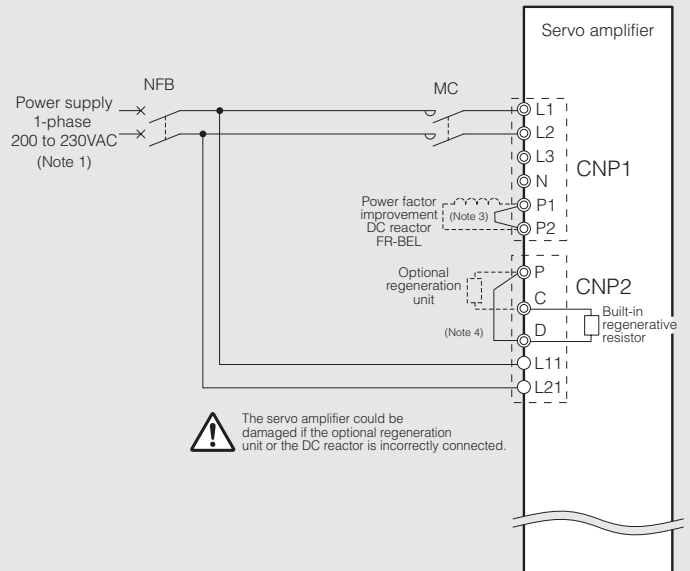

(3) 3-phase 200V 0.1kW to 3.5kW  
or 3-phase 400V 0.6kW to 2kW

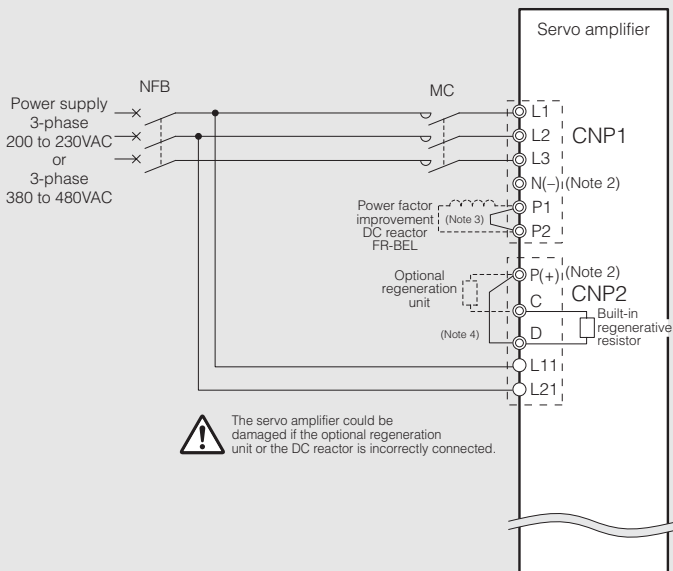

(4) 3-phase 200V 5kW or 7kW,  
or 3-phase 400V 3.5kW to 7kW

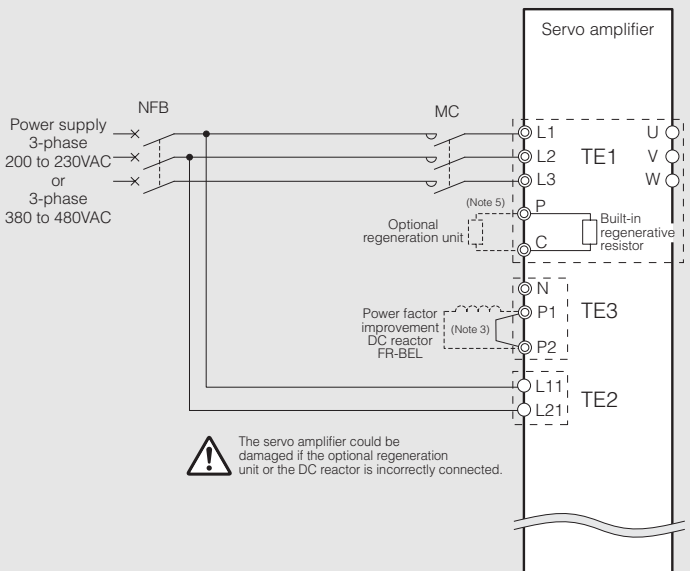

Notes:

1. When using a 1-phase 200 to 230VAC, connect the power supply to the L1 and L2 terminals. Do not connect anything to L3.
2. N- and P+ are for 3-phase 400VAC servo amplifiers. For 3-phase 200VAC, the terminals are N and P.
3. Disconnect P1 and P2 when using the DC reactor.
4. Disconnect P(+) and D when connecting the optional regeneration unit externally.
5. Disconnect the wires for the built-in regenerative resistor (P and C) when connecting the optional regeneration unit externally.

# Standard Wiring Diagram

## (5) 3-phase 200V/400V 11kW to 22kW

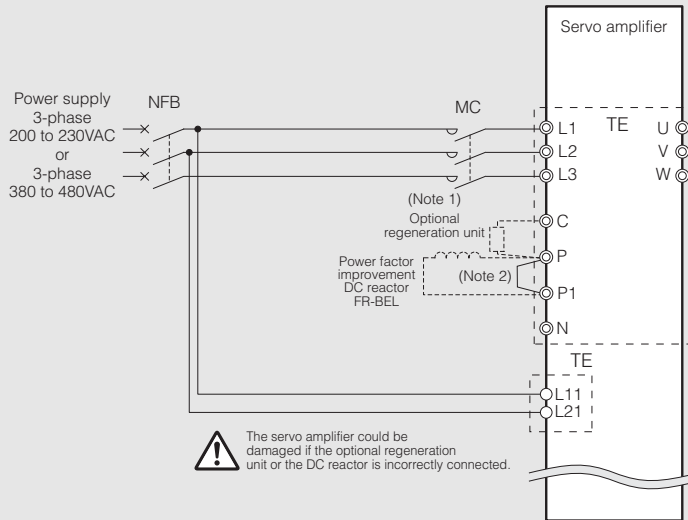

## (6) 3-phase 200V/400V 30kW or larger (Note 3)

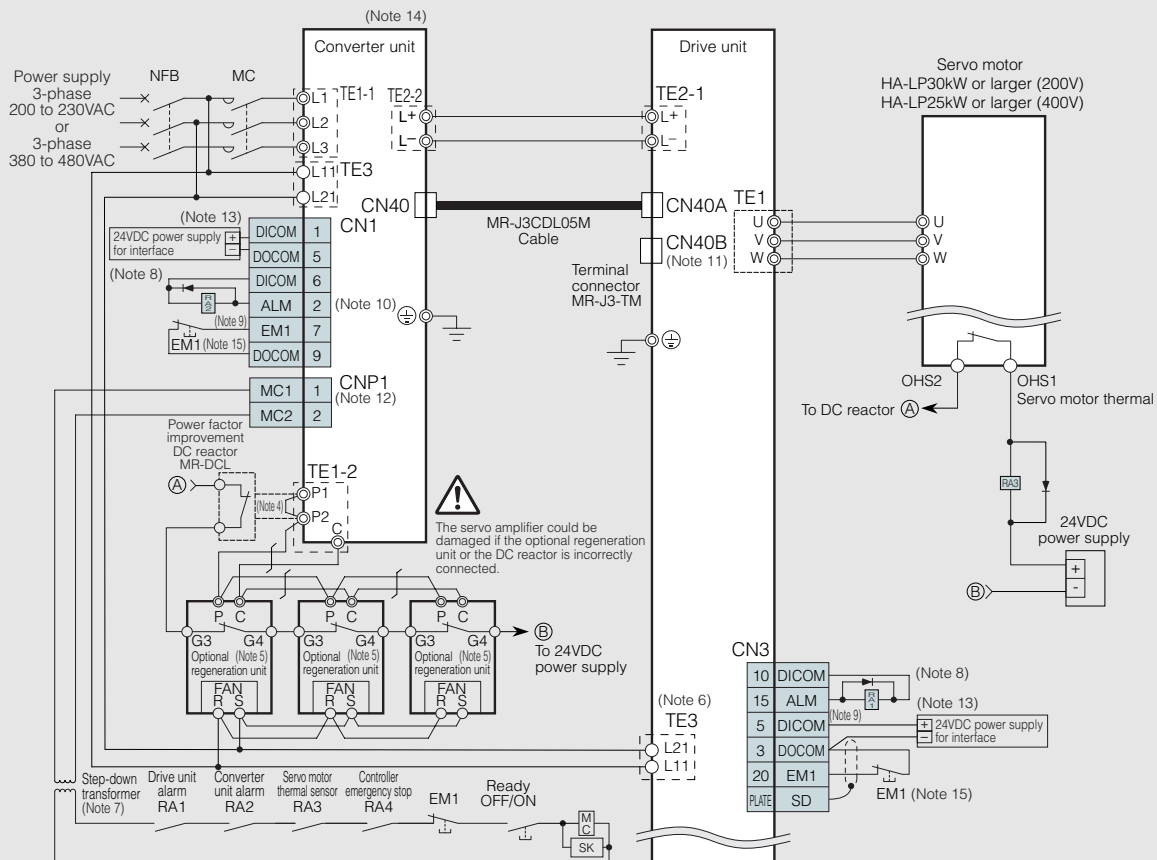

### Notes:

- Servo amplifiers, 11kW or larger do not have a built-in regenerative resistor.
- Remove the short bar between P and P1 when using the DC reactor.
- This wiring diagram is for MR-J3-DU□B(4). For MR-J3-DU□A(4), refer to "MR-J3-□A SERVO AMPLIFIER INSTRUCTION MANUAL".
- Remove the short bar between P1 and P2 when using the DC reactor.
- This is for MR-RB137 (for 200V) or MR-RB138-4 (for 400V). Three units of MR-RB137 or MR-RB138-4 are required for each converter unit (tolerable regenerative power 3900W).
- The phases of the power supply connected to L11 and L21 on the converter unit and the drive unit must always match the phases connected to L1 and L2. An incorrect connection could damage the drive unit and/or the converter unit.
- This is for 400V. The 200V does not require a step-down transformer.
- Do not reverse the diode's direction. Connecting it backwards could cause the drive unit and/or the converter unit to malfunction such that the signals are not output, and the emergency stop and other safety circuits are inoperable.
- Select a device that does not make the circuit current exceed 40mA.
- The malfunction (ALM) signal is conducted to DOCOM in normal alarm-free condition.
- Always connect the terminal connector (MR-J3-TM) to CN40B.
- MC1 and MC2 outputs are controlled by the converter unit. To invalidate CNP1, creating a system same as that of the prior servo amplifier; refer to "MR-J3-□B SERVO AMPLIFIER INSTRUCTION MANUAL" for details.
- The interface power supply can be shared with the drive unit and the converter unit. When all of the input/output points are used, 150mA is required for the drive unit and 130mA for the converter unit. The current capacity can be stepped down according to the number of input/output points in use.
- A converter unit is required per drive unit.
- Create a circuit that shuts off the forced stop (EM1) of the converter unit and the drive unit at the same time.

## Connector CN2 connection examples

### (7) HF-KP/MP series

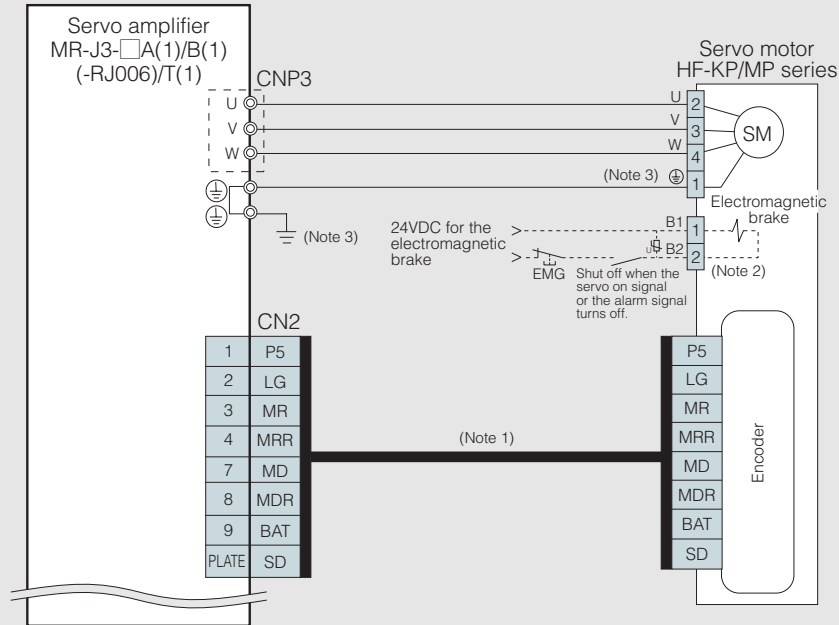

### (8) HF-SP series

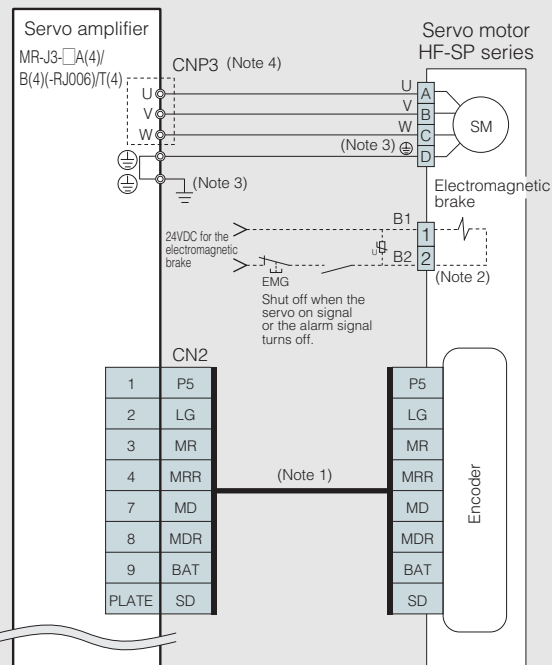

### (9) HC-LP/RP/UP series or HA-LP502/702

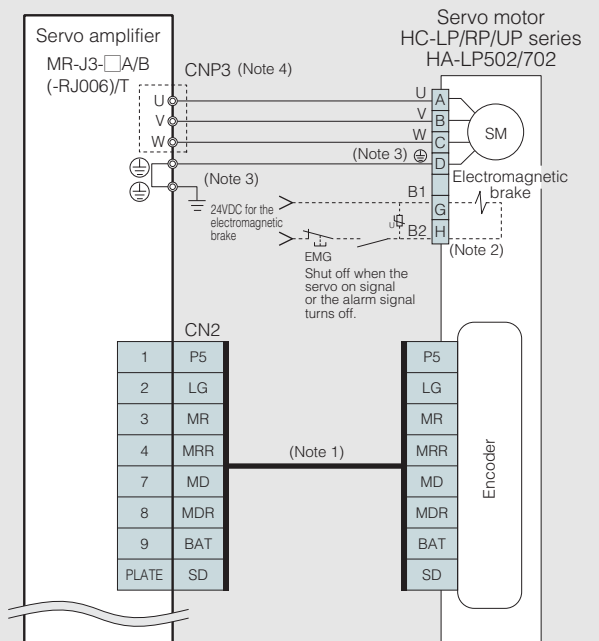

#### Notes:

1. Refer to "MR-J3 SERVO AMPLIFIER INSTRUCTION MANUAL" for details. When using a four-wire type cable (MR-EKCB30M-H/-L to MR-EKCB50M-H/-L) for HF-KP/HF-MP series, change the parameter No. PC22 for MR-J3-□A□ or MR-J3-□T□, or PC04 for MR-J3-□B□.
2. This is for the motor with an electromagnetic brake. The electromagnetic brake terminals (B1, B2) do not have polarity. A separate connector from the motor power supply connector is prepared as an electromagnetic brake connector for HC-LP202B, 302B, and HC-UP202B to 502B.
3. For grounding, connect the ground wire to the control box's protection ground terminal via the servo amplifier's protection ground (PE) terminal.
4. For servo amplifiers, 200V 5kW or larger and 400V 3.5kW or larger, U, V, W terminals are available in TE1.





# Amplifier Dimensions

## MR-J3-□A□

(Unit: mm)

### ● MR-J3-10A, 20A, 10A1, 20A1 (Note)

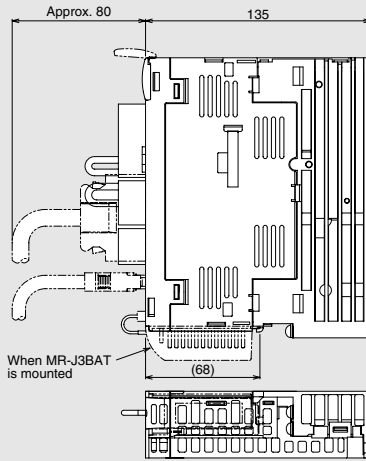
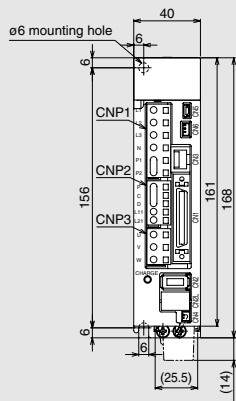

< Terminal arrangement >

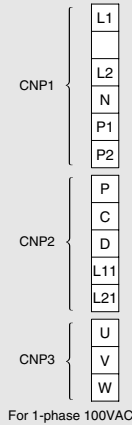

For 1-phase 100VAC

< Terminal arrangement >

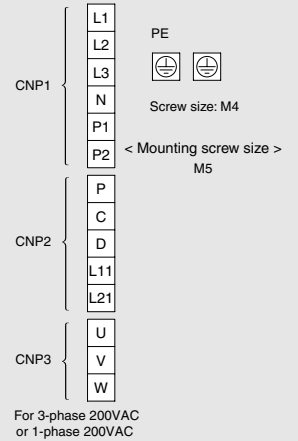

For 3-phase 200VAC or 1-phase 200VAC

### ● MR-J3-40A, 60A, 40A1 (Note)

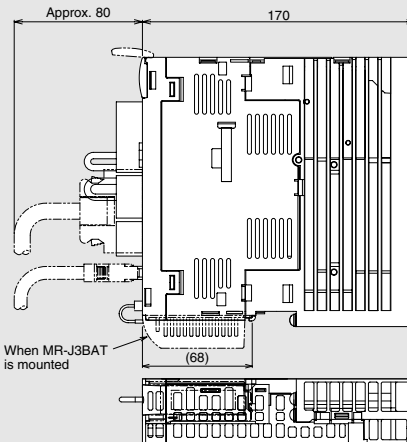
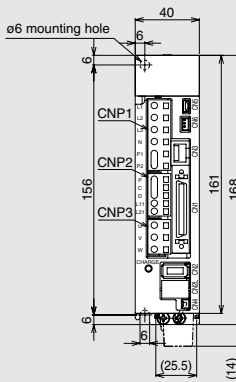

< Terminal arrangement >

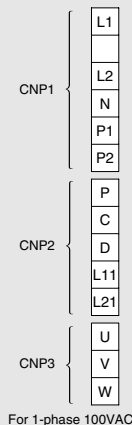

For 1-phase 100VAC

< Terminal arrangement >

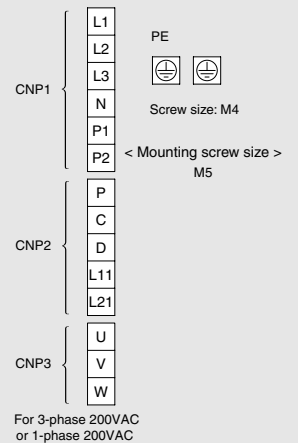

For 3-phase 200VAC or 1-phase 200VAC

### ● MR-J3-70A, 100A (Note)

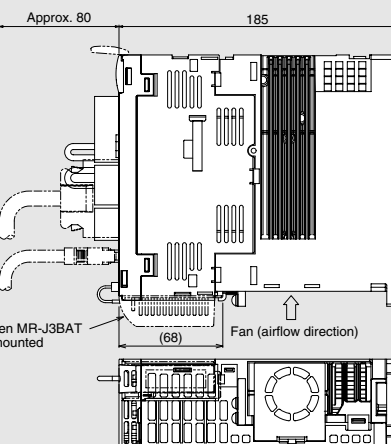
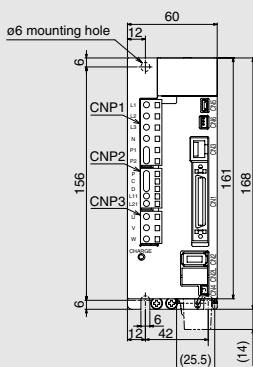

< Terminal arrangement >

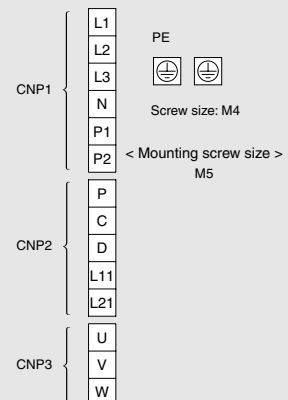

Note: The connectors CNP1, CNP2 and CNP3 (insertion type) are supplied with the servo amplifier.

# Amplifier Dimensions

(Unit: mm)

## ● MR-J3-60A4, 100A4 (Note)

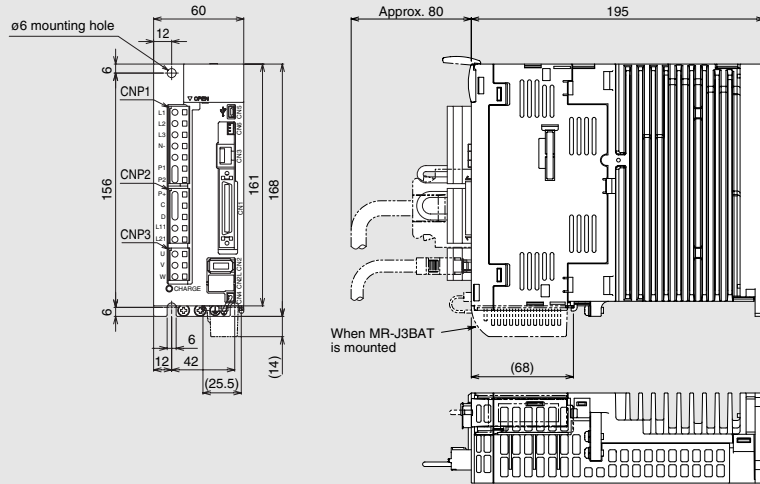

< Terminal arrangement >

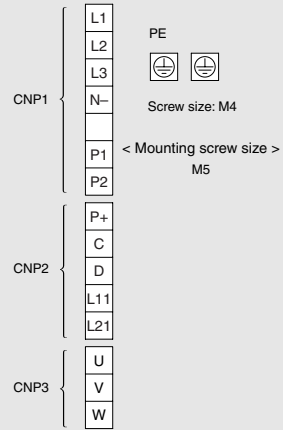

## ● MR-J3-200A, 350A (Note)

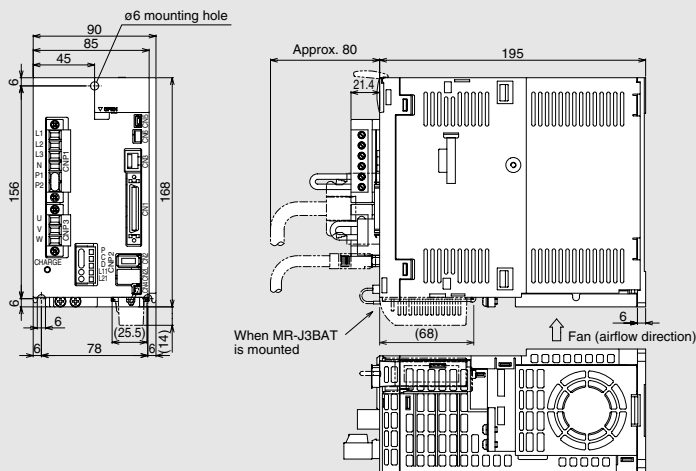

< Terminal arrangement >

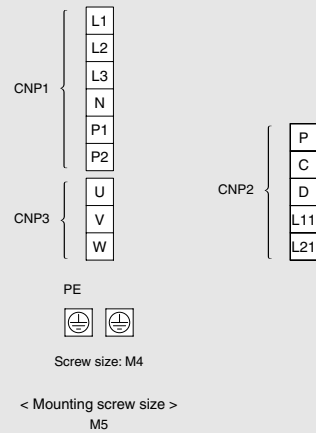

## ● MR-J3-200A4 (Note)

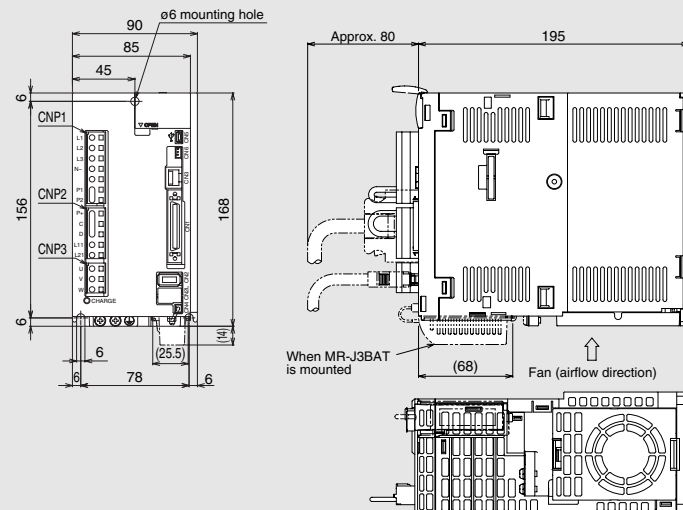

< Terminal arrangement >

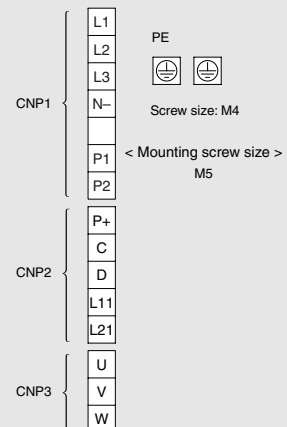

# Amplifier Dimensions

(Unit: mm)

## ● MR-J3-500A, 350A4, 500A4

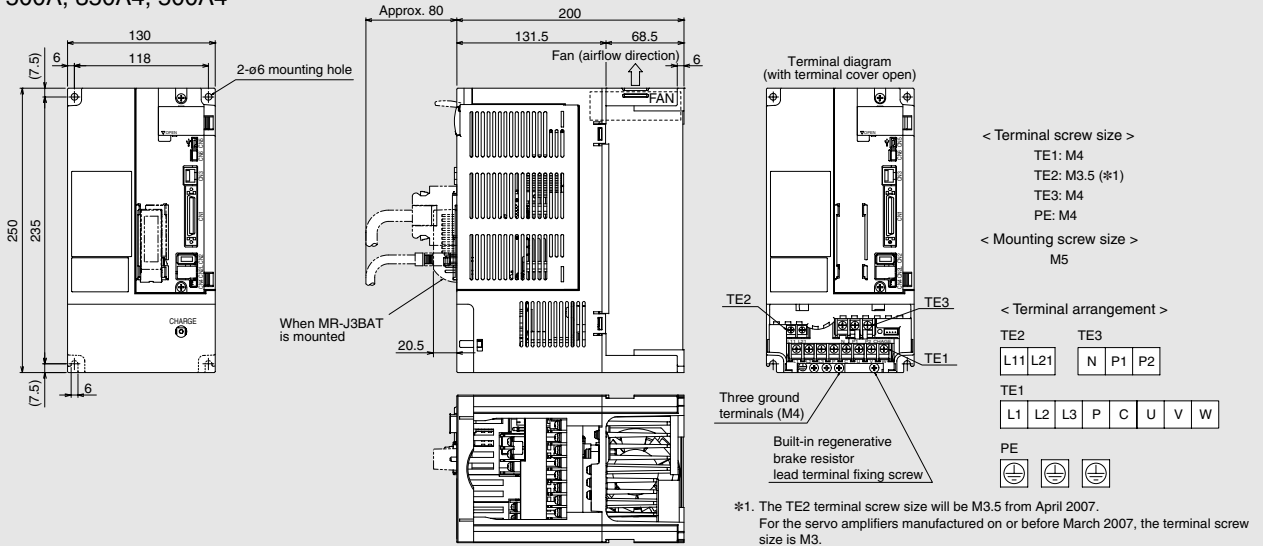

## ● MR-J3-700A, 700A4

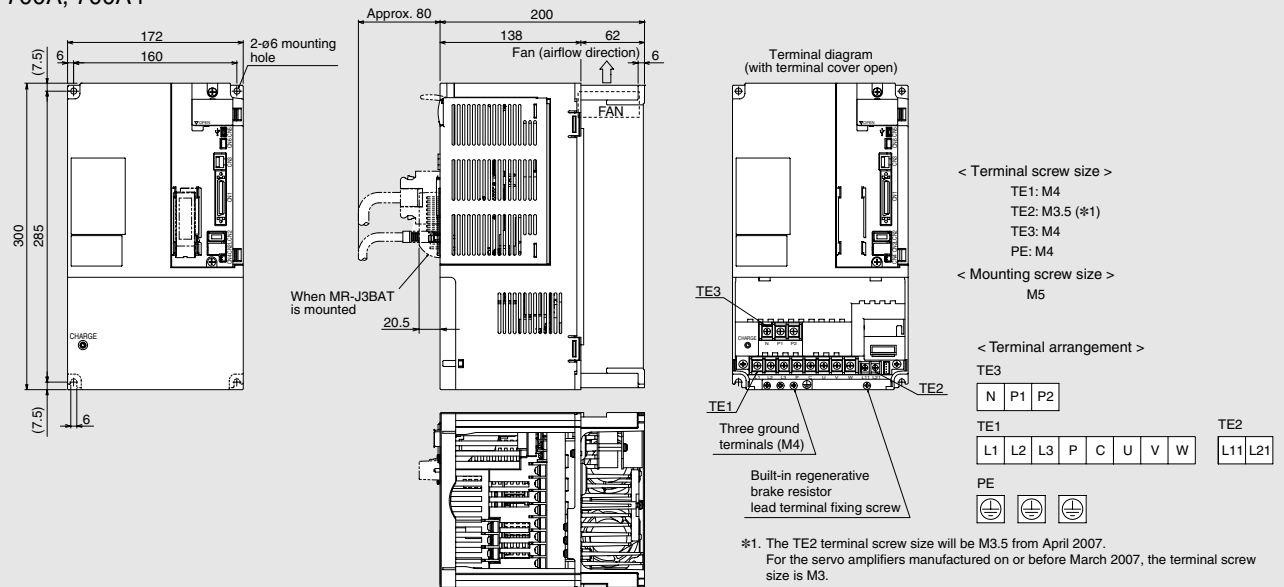

## ● MR-J3-11KA to 22KA, 11KA4 to 22KA4

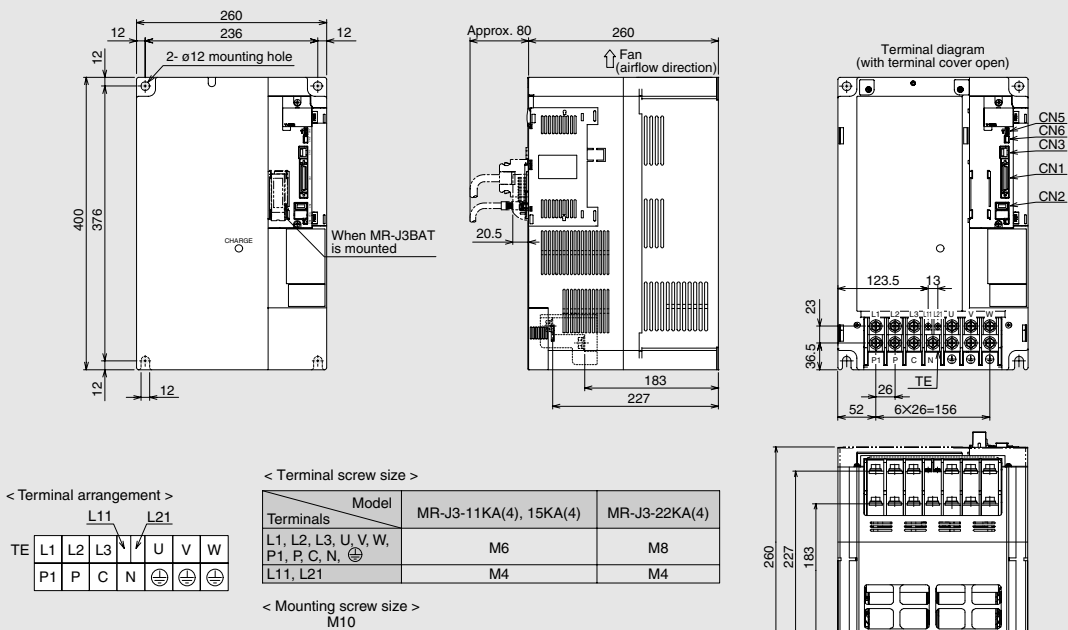

# Drive Unit Dimensions

## MR-J3-DU□A(4)

(Unit: mm)

- MR-J3-DU30KA, DU37KA, DU45KA4, DU55KA4

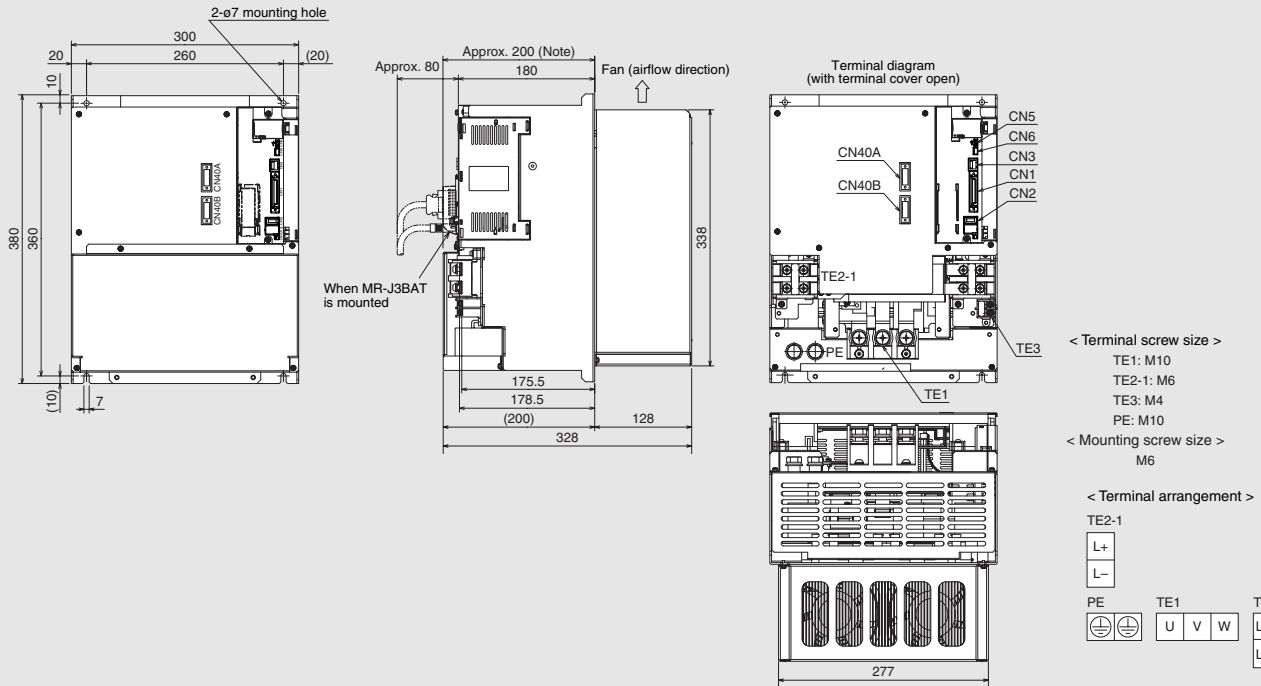

- MR-J3-DU30KA4, DU37KA4

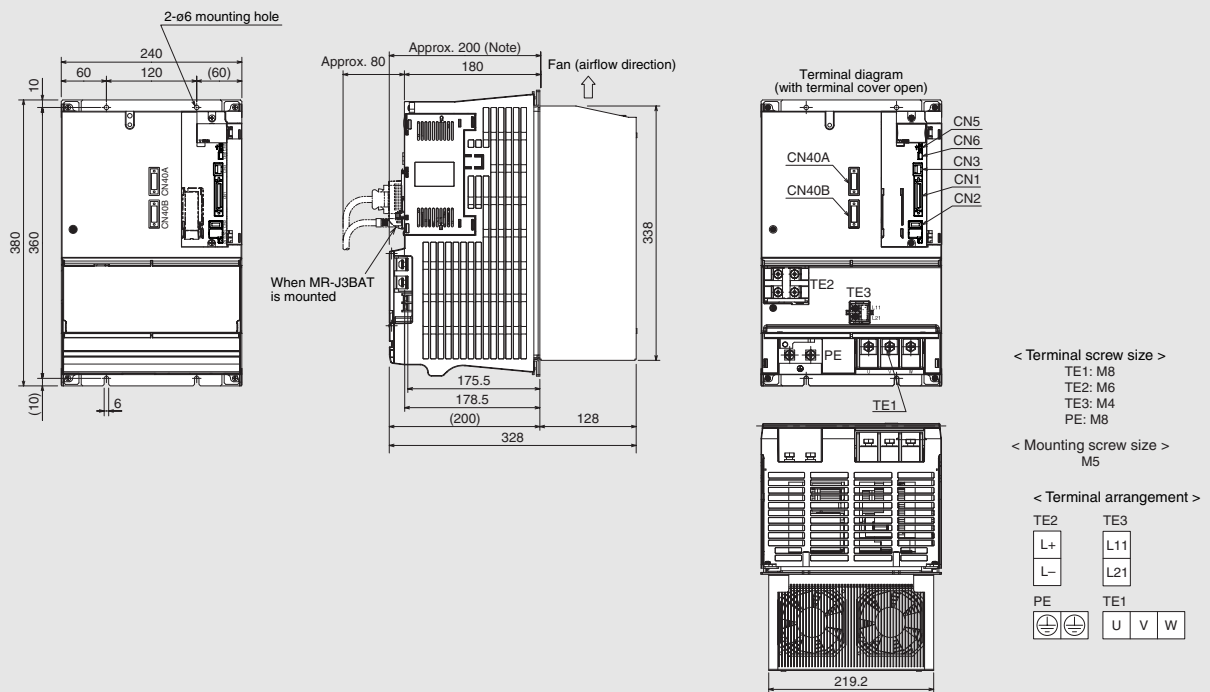

# Converter Unit Dimensions

## MR-J3-CR55K(4)

(Unit: mm)

### ● MR-J3-CR55K, CR55K4 (Note)

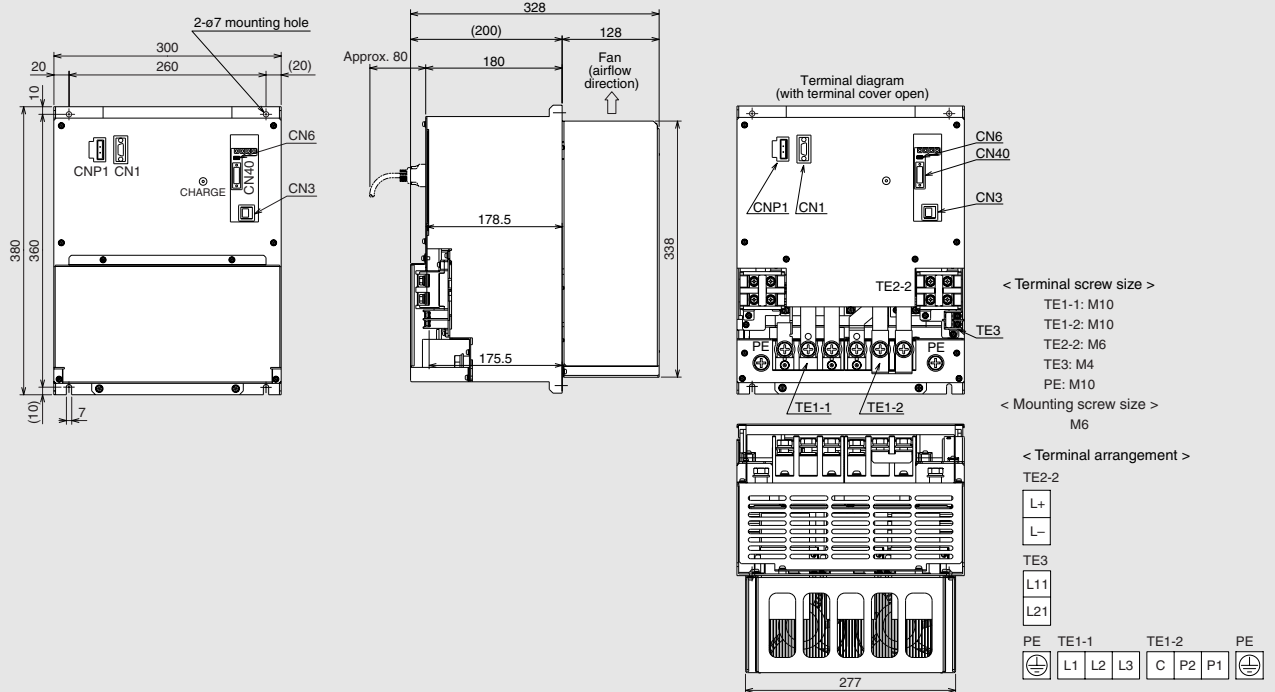

### ● Panel-cut dimensions for converter unit and drive unit (Note)

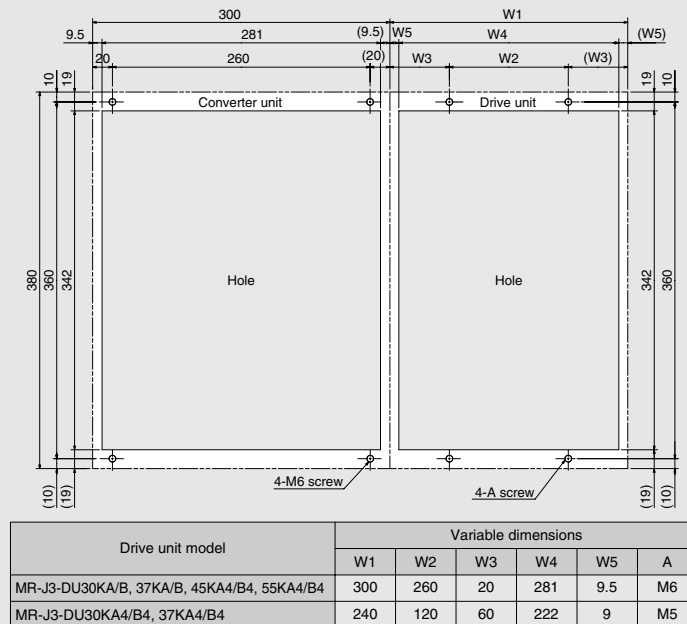

# Peripheral Equipment (MR-J3-B)

## Connections with peripheral equipment (Note 1)

Peripheral equipment is connected to MR-J3-B as described below.

Connectors, cables, options, and other necessary equipment are available so that users can set up MR-J3-B easily and begin using it right away. Through its SSCNET III-compatible simple connections, the MR-J3-B series reduce wiring time and chances of wiring errors.

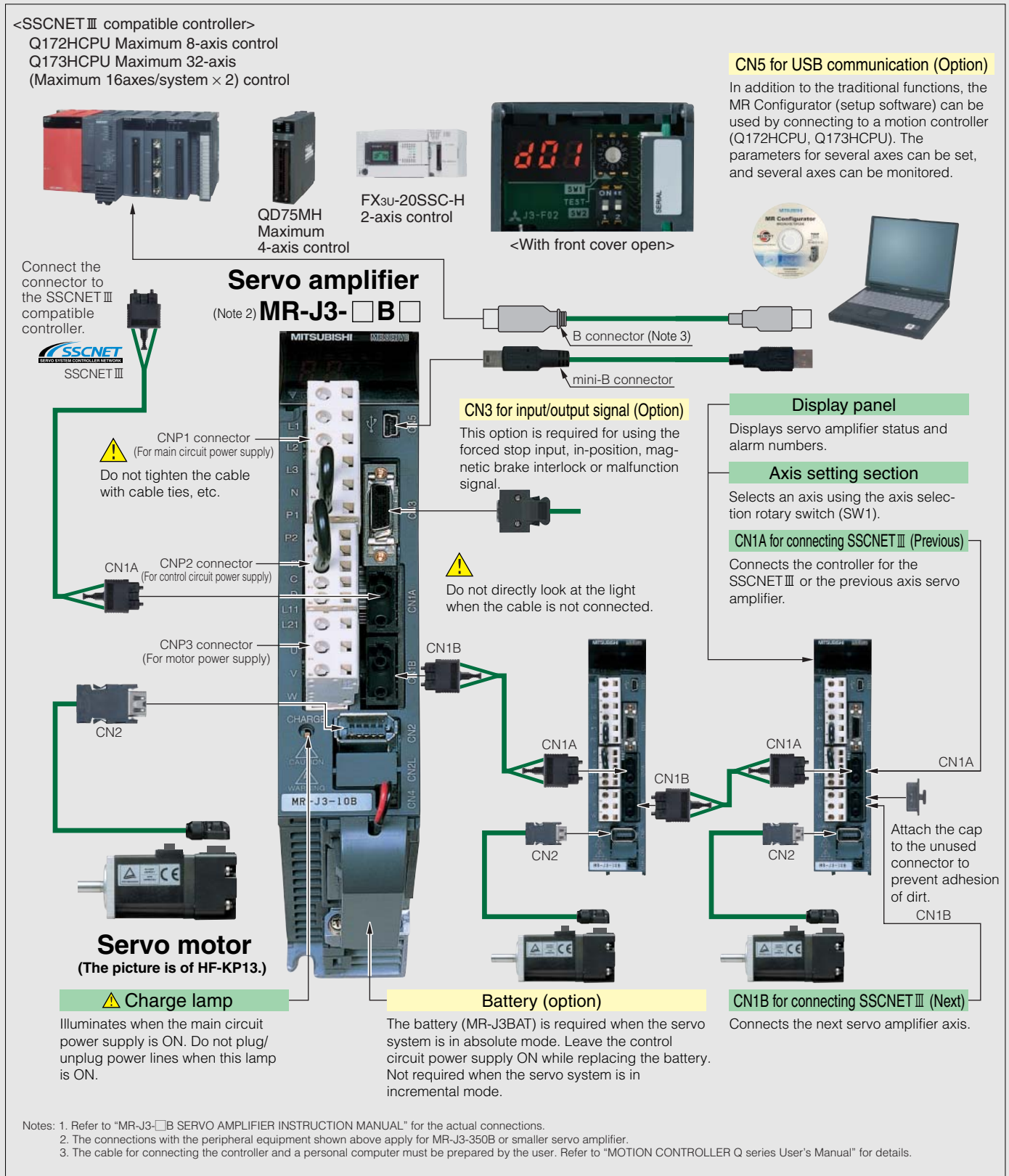

Notes: 1. Refer to "MR-J3-□B SERVO AMPLIFIER INSTRUCTION MANUAL" for the actual connections.  
 2. The connections with the peripheral equipment shown above apply for MR-J3-350B or smaller servo amplifier.  
 3. The cable for connecting the controller and a personal computer must be prepared by the user. Refer to "MOTION CONTROLLER Q series User's Manual" for details.

# Amplifier Specifications



## MR-J3-B servo amplifier specifications: 100VAC/200VAC, 22kW or smaller

Servo amplifier model MR-J3-		10B	20B	40B	60B	70B	100B	200B	350B	500B	700B	11KB	15KB	22KB	10B1	20B1	40B1
Main circuit power supply	Voltage/frequency (Note 1, 2)	3-phase 200 to 230VAC 50/60Hz or 1-phase 200 to 230VAC 50/60Hz (Note 10)						3-phase 200 to 230VAC 50/60Hz						1-phase 100 to 120VAC 50/60Hz			
	Permissible voltage fluctuation	For 3-phase 200 to 230VAC; 3-phase 170 to 253VAC For 1-phase 200 to 230VAC; 1-phase 170 to 253VAC						3-phase 170 to 253VAC						1-phase 85 to 132VAC			
	Permissible frequency fluctuation	±5% maximum															
Control circuit power supply	Voltage/frequency	1-phase 200 to 230VAC 50/60Hz (Note 10)						1-phase 200 to 230VAC 50/60Hz						1-phase 100 to 120VAC 50/60Hz			
	Permissible voltage fluctuation	1-phase 170 to 253VAC															
	Permissible frequency fluctuation	±5% maximum															
	Power consumption (W)	30						45						30			
Interface power supply		24VDC ±10% (required current capacity: 150mA (Note 7))															
Regenerative resistor/ tolerable regenerative power (W) (Note 3, 4)	Built-in regenerative resistor	—	10	10	10	20	20	100	100	130	170	—	—	—	—	10	10
	External regenerative resistor (Standard accessory) (Note 5, 6)	—	—	—	—	—	—	—	—	—	—	500 (800)	850 (1300)	850 (1300)	—	—	—
Control system		Sine-wave PWM control/current control system															
Dynamic brake		Built-in (Note 8)										External option		Built-in (Note 8)			
Safety features		Overcurrent shutdown, regeneration overvoltage shutdown, overload shutdown (electronic thermal), servo motor overheat protection, encoder fault protection, regeneration fault protection, undervoltage/sudden power outage protection, overspeed protection, excess error protection															
Structure		Self-cooling open (IP00)						Fan cooling open (IP00)						Self-cooling open (IP00)			
Environment	Ambient temperature (Note 9)	0 to 55°C (32 to 131°F) (non freezing), storage: -20 to 65°C (-4 to 149°F) (non freezing)															
	Ambient humidity	90% RH maximum (non condensing), storage: 90% RH maximum (non condensing)															
	Atmosphere	Indoors (no direct sunlight); no corrosive gas, inflammable gas, oil mist or dust															
	Elevation	1000m or less above sea level															
	Vibration	5.9m/s <sup>2</sup> maximum															
Mass (kg [lb])		0.8 (1.8)	0.8 (1.8)	1.0 (2.2)	1.0 (2.2)	1.4 (3.1)	1.4 (3.1)	2.3 (5.1)	2.3 (5.1)	4.6 (10)	6.2 (14)	18 (40)	18 (40)	19 (42)	0.8 (1.8)	0.8 (1.8)	1.0 (2.2)

- Notes: 1. Rated output and rated speed of the servo motor used in combination with the servo amplifier are as indicated when using the power supply voltage and frequency listed. The torque drops when the power supply voltage is less than specified.
2. For torque characteristics when combined with a servo motor, refer to the section "Servo motor torque characteristics" in this catalog.
3. Optimal regenerative resistor varies for each system. Select the most suitable regenerative resistor by using the capacity selection software.
4. Refer to the section "Options ●Optional regeneration unit" in this catalog for the tolerable regenerative power (W).
5. The servo amplifier (MR-J3-□KB-PX) without an enclosed regenerative resistor is also available.
6. The value applies when the external regenerative resistors, GRZG400-□□, (standard accessory) are used with cooling fans (2 units of 92 X 92mm, minimum air flow: 1.0m<sup>3</sup>/min). Note that change in the parameter No. PA02 is required.
7. 150mA is the value when all of the input/output points are used. The current capacity can be stepped down according to the number of input/output points in use. Refer to "MR-J3-□B SERVO AMPLIFIER INSTRUCTION MANUAL" for details.
8. Special specification models without a dynamic brake, MR-J3-□B-ED and MR-J3-□B1-ED, are also available.
9. The MR-J3-350B or smaller servo amplifier can be installed closely. In this case, keep the ambient temperature within 0 to 45°C (32 to 113°F), or use the servo amplifier with 75% or less of the effective load rate.
10. The special specification model, MR-J3-□B-U004, is also available for 1-phase 200 to 240VAC.

# Amplifier Specifications



## MR-J3-B servo amplifier specifications: 200VAC, 30kW or larger

		Drive unit model	MR-J3-DU30KB	MR-J3-DU37KB
Drive unit	Main circuit power supply	Voltage/frequency (Note 1)	The drive unit's main circuit power is supplied from the converter unit.	
		Permissible voltage fluctuation		
		Permissible frequency fluctuation		
	Control circuit power supply	Voltage/frequency	1-phase 200 to 230VAC 50/60Hz	
		Permissible voltage fluctuation	1-phase 170 to 253VAC	
		Permissible frequency fluctuation	±5% maximum	
		Power consumption (W)	45	
	Interface power supply	24VDC ±10% (required current capacity: 150mA (Note 3))		
	Control system	Sine-wave PWM control/current control system		
	Dynamic brake	External option		
Safety features	Overcurrent shutdown, overload shutdown (electronic thermal), servo motor overheat protection, encoder fault protection, undervoltage/sudden power outage protection, overspeed protection, excess error protection			
Structure	Fan cooling open (IP00)			
Mass (kg [lb])	26 (57)			
Converter unit	Converter unit model		MR-J3-CR55K	
	Main circuit power supply	Voltage/frequency (Note 1, 2)	3-phase 200 to 230VAC 50/60Hz	
		Permissible voltage fluctuation	3-phase 170 to 253VAC	
		Permissible frequency fluctuation	±5% maximum	
	Control circuit power supply	Voltage/frequency	1-phase 200 to 230VAC 50/60Hz	
		Permissible voltage fluctuation	1-phase 170 to 253VAC	
		Permissible frequency fluctuation	±5% maximum	
		Power consumption (W)	45	
	Interface power supply	24VDC ±10% (required current capacity: 130mA (Note 3))		
	Safety features	Regeneration overvoltage shutdown, regeneration fault protection, overload shutdown (electronic thermal), undervoltage/sudden power outage protection		
Structure	Fan cooling open (IP00)			
Mass (kg [lb])	25 (55)			
Drive unit/ Converter unit	Environment	Ambient temperature	0 to 55°C (32 to 131°F) (non freezing), storage: -20 to 65°C (-4 to 149°F) (non freezing)	
		Ambient humidity	90% RH maximum (non condensing), storage: 90% RH maximum (non condensing)	
		Atmosphere	Indoors (no direct sunlight); no corrosive gas, inflammable gas, oil mist or dust	
		Elevation	1000m or less above sea level	
		Vibration	5.9m/s <sup>2</sup> maximum	

- Notes: 1. Rated output and rated speed of the servo motor used in combination with the drive unit and the converter unit are as indicated when using the power supply voltage and frequency listed. The torque drops when the power supply voltage is less than specified.  
 2. For torque characteristics when combined with a servo motor, refer to the section "Servo motor torque characteristics" in this catalog.  
 3. The interface power supply can be shared with the drive unit and the converter unit. When all of the input/output points are used, 150mA is required for the drive unit, and 130mA is required for the converter unit. The current capacity can be stepped down according to the number of input/output points in use. Refer to "MR-J3-□B SERVO AMPLIFIER INSTRUCTION MANUAL" for details.



# Amplifier Specifications



## MR-J3-B servo amplifier specifications: 400VAC, 22kW or smaller

Servo amplifier model MR-J3-		60B4	100B4	200B4	350B4	500B4	700B4	11KB4	15KB4	22KB4	
Main circuit power supply	Voltage/frequency (Note 1, 2)	3-phase 380 to 480VAC 50/60Hz									
	Permissible voltage fluctuation	3-phase 323 to 528VAC									
	Permissible frequency fluctuation	±5% maximum									
Control circuit power supply	Voltage/frequency	1-phase 380 to 480VAC 50/60Hz									
	Permissible voltage fluctuation	1-phase 323 to 528VAC									
	Permissible frequency fluctuation	±5% maximum									
	Power consumption (W)	30				45					
Interface power supply		24VDC ±10% (required current capacity: 150mA (Note 7))									
Regenerative resistor/ tolerable regenerative power (W) (Note 3, 4)	Built-in regenerative resistor	15	15	100	100	130 (Note 9)	170 (Note 9)	—	—	—	
	External regenerative resistor (Standard accessory) (Note 5, 6)	—	—	—	—	—	—	500 (800)	850 (1300)	850 (1300)	
Control system		Sine-wave PWM control/current control system									
Dynamic brake		Built-in (Note 8, 10)						External option			
Safety features		Overcurrent shutdown, regeneration overvoltage shutdown, overload shutdown (electronic thermal), servo motor overheat protection, encoder fault protection, regeneration fault protection, undervoltage/sudden power outage protection, overspeed protection, excess error protection									
Structure		Self-cooling open (IP00)			Fan cooling open (IP00)						
Environment	Ambient temperature	0 to 55°C (32 to 131°F) (non freezing), storage: -20 to 65°C (-4 to 149°F) (non freezing)									
	Ambient humidity	90% RH maximum (non condensing), storage: 90% RH maximum (non condensing)									
	Atmosphere	Indoors (no direct sunlight); no corrosive gas, inflammable gas, oil mist or dust									
	Elevation	1000m or less above sea level									
	Vibration	5.9m/s <sup>2</sup> maximum									
Mass (kg [lb])		1.7 (3.7)	1.7 (3.7)	2.1 (4.6)	4.6 (10)	4.6 (10)	6.2 (14)	18 (40)	18 (40)	19 (42)	

- Notes: 1. Rated output and rated speed of the servo motor used in combination with the servo amplifier are as indicated when using the power supply voltage and frequency listed. The torque drops when the power supply voltage is less than specified.
2. For torque characteristics when combined with a servo motor, refer to the section "Servo motor torque characteristics" in this catalog.
3. Optimal regenerative resistor varies for each system. Select the most suitable regenerative resistor by using the capacity selection software.
4. Refer to the section "Options ●Optional regeneration unit" in this catalog for the tolerable regenerative power (W).
5. The servo amplifier (MR-J3-□KB4-PX) without an enclosed regenerative resistor is also available.
6. The value applies when the external regenerative resistors, GRZG400-□Ω, (standard accessory) are used with cooling fans (2 units of 92 X 92mm, minimum air flow: 1.0m<sup>3</sup>/min). Note that change in the parameter No. PA02 is required.
7. 150mA is the value when all of the input/output points are used. The current capacity can be stepped down according to the number of input/output points in use. Refer to "MR-J3-□B SERVO AMPLIFIER INSTRUCTION MANUAL" for details.
8. Special specification models without a dynamic brake, MR-J3-□B4-ED, are also available.
9. The amplifier built-in resistor is compatible with the maximum torque deceleration when the motor is used within the rated speed and the recommended load/motor inertia moment ratio. Contact Mitsubishi if the operating motor speed and the load/motor inertia moment ratio exceed the rated speed and the recommended ratio.
10. For the servo amplifier 5kW or 7kW, the load/motor of inertia moment ratio must be 5 times or less when the amplifier built-in dynamic brake is used, and the motor speed exceeds 2000r/min.

# Amplifier Specifications



## MR-J3-B servo amplifier specifications: 400VAC, 30kW or larger

		Drive unit model	MR-J3-DU30KB4	MR-J3-DU37KB4	MR-J3-DU45KB4	MR-J3-55KB4
Drive unit	Main circuit power supply	Voltage/frequency (Note 1)	The drive unit's main circuit power is supplied from the converter unit.			
		Permissible voltage fluctuation				
		Permissible frequency fluctuation				
	Control circuit power supply	Voltage/frequency	1-phase 380 to 480VAC 50/60Hz			
		Permissible voltage fluctuation	1-phase 323 to 528VAC			
		Permissible frequency fluctuation	±5% maximum			
		Power consumption (W)	45			
	Interface power supply	24VDC ±10% (required current capacity: 150mA (Note 3))				
	Control system	Sine-wave PWM control/current control system				
	Dynamic brake	External option				
Safety features	Overcurrent shutdown, overload shutdown (electronic thermal), servo motor overheat protection, encoder fault protection, undervoltage/sudden power outage protection, overspeed protection, excess error protection					
Structure	Fan cooling open (IP00)					
Mass (kg [lb])	18 (40)			26 (57)		
Converter unit	Converter unit model		MR-J3-CR55K4			
	Main circuit power supply	Voltage/frequency (Note 1, 2)	3-phase 380 to 480VAC 50/60Hz			
		Permissible voltage fluctuation	3-phase 323 to 528VAC			
		Permissible frequency fluctuation	±5% maximum			
	Control circuit power supply	Voltage/frequency	1-phase 380 to 480VAC 50/60Hz			
		Permissible voltage fluctuation	1-phase 323 to 528VAC			
		Permissible frequency fluctuation	±5% maximum			
		Power consumption (W)	45			
	Interface power supply	24VDC ±10% (required current capacity: 130mA (Note 3))				
	Safety features	Regeneration overvoltage shutdown, regeneration fault protection, overload shutdown (electronic thermal), undervoltage/sudden power outage protection				
Structure	Fan cooling open (IP00)					
Mass (kg [lb])	25 (55)					
Drive unit/ Converter unit	Environment	Ambient temperature	0 to 55°C (32 to 131°F) (non freezing), storage: -20 to 65°C (-4 to 149°F) (non freezing)			
		Ambient humidity	90% RH maximum (non condensing), storage: 90% RH maximum (non condensing)			
		Atmosphere	Indoors (no direct sunlight); no corrosive gas, inflammable gas, oil mist or dust			
		Elevation	1000m or less above sea level			
		Vibration	5.9m/s <sup>2</sup> maximum			

- Notes: 1. Rated output and rated speed of the servo motor used in combination with the drive unit and the converter unit are as indicated when using the power supply voltage and frequency listed. The torque drops when the power supply voltage is less than specified.  
 2. For torque characteristics when combined with a servo motor, refer to the section "Servo motor torque characteristics" in this catalog.  
 3. The interface power supply can be shared with the drive unit and the converter unit. When all of the input/output points are used, 150mA is required for the drive unit, and 130mA is required for the converter unit. The current capacity can be stepped down according to the number of input/output points in use. Refer to "MR-J3-□B SERVO AMPLIFIER INSTRUCTION MANUAL" for details.

# Standard Wiring Diagram

## MR-J3-□B□

### ● Connection example

#### Main circuit/control circuit power supply connection

The connection differs according to the power voltage.  
 →Refer to the main circuit/control circuit power supply connection examples (1) to (6).

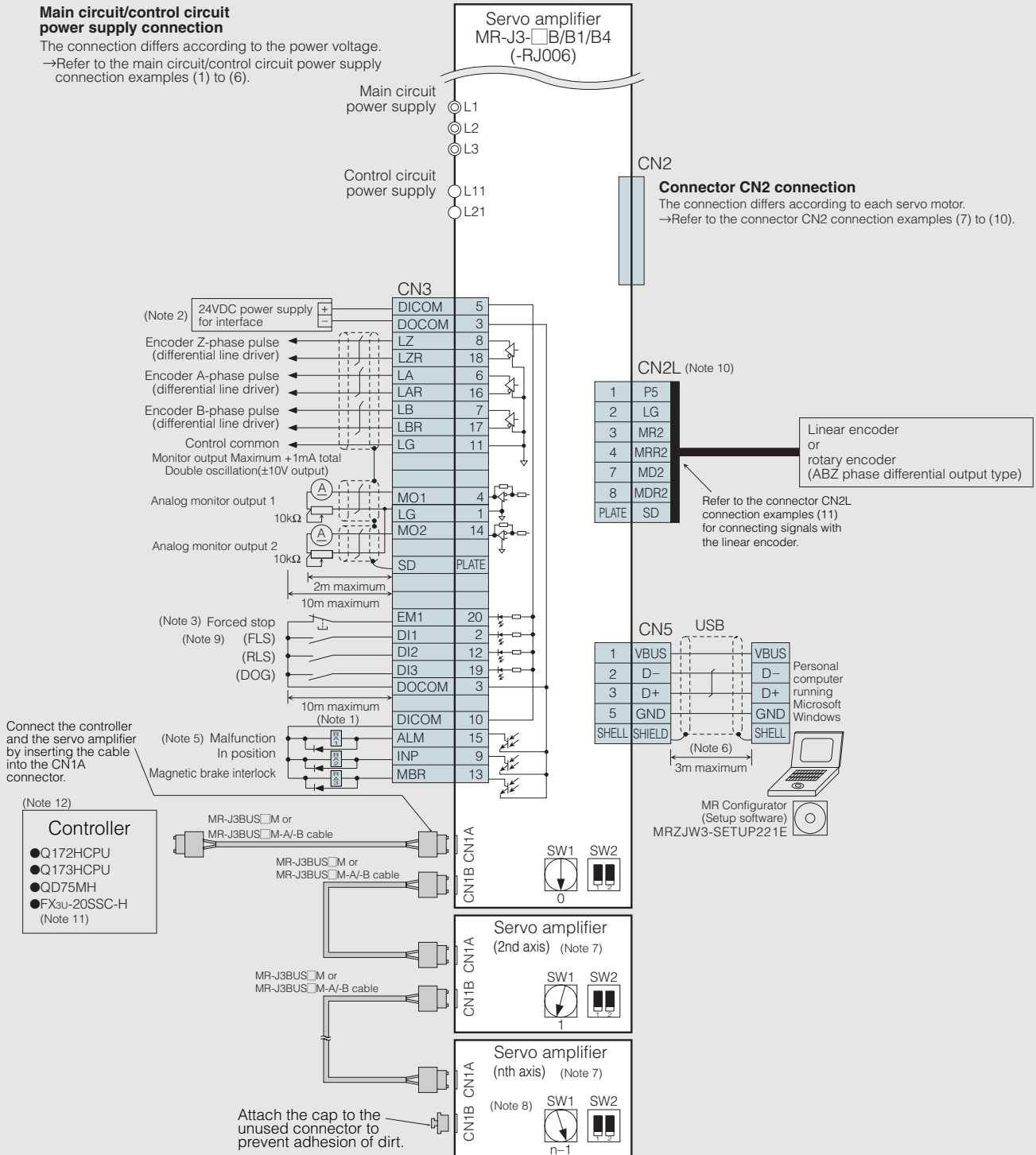

# Amplifier Dimensions

## MR-J3-□□B□□

(Unit: mm)

### ● MR-J3-10B, 20B, 10B1, 20B1 (Note)

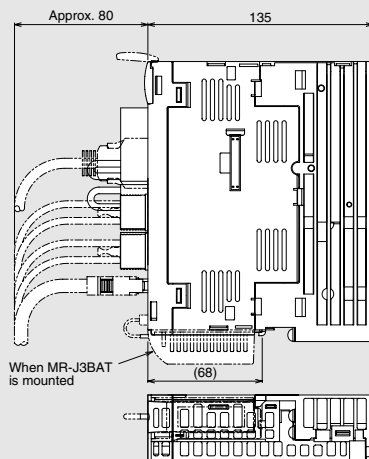
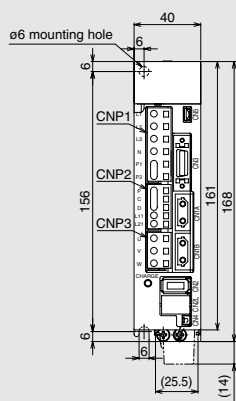

< Terminal arrangement >

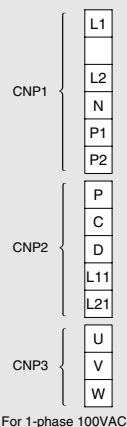

For 1-phase 100VAC

< Terminal arrangement >

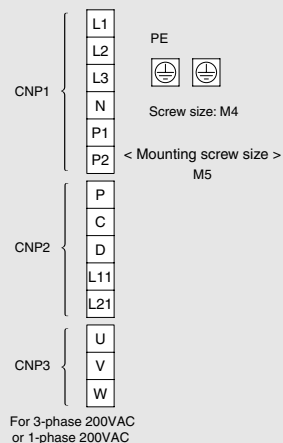

For 3-phase 200VAC or 1-phase 200VAC

### ● MR-J3-40B, 60B, 40B1 (Note)

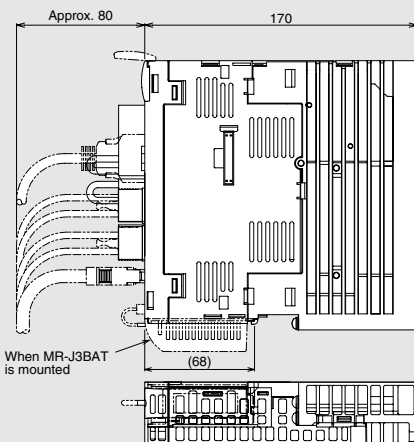
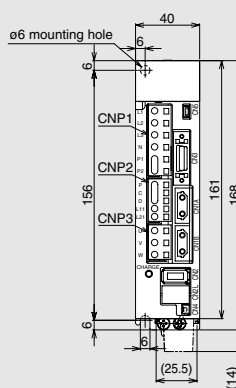

< Terminal arrangement >

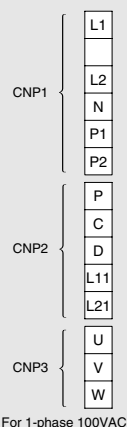

For 1-phase 100VAC

< Terminal arrangement >

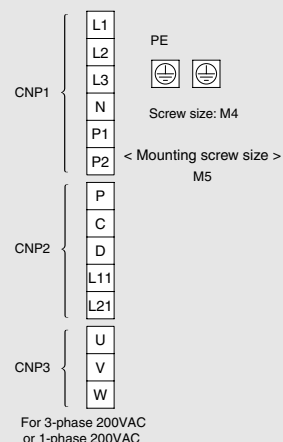

For 3-phase 200VAC or 1-phase 200VAC

### ● MR-J3-70B, 100B (Note)

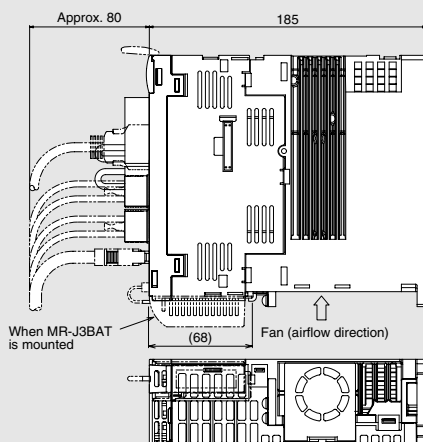
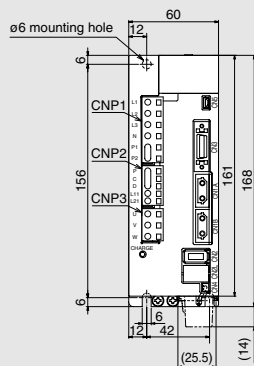

< Terminal arrangement >

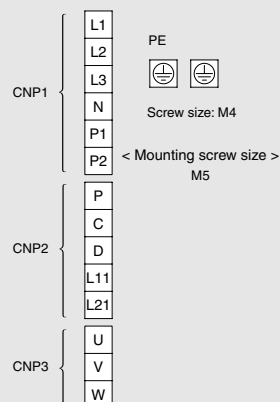

# Amplifier Dimensions

(Unit: mm)

## ● MR-J3-60B4, 100B4 (Note)

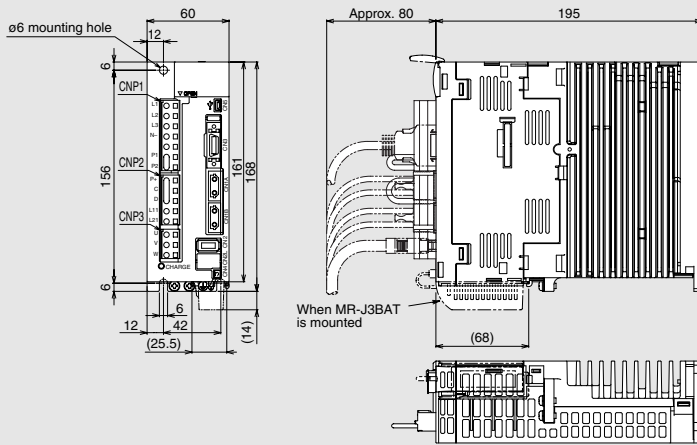

< Terminal arrangement >

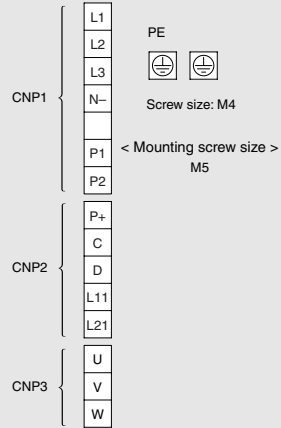

## ● MR-J3-200B, 350B (Note)

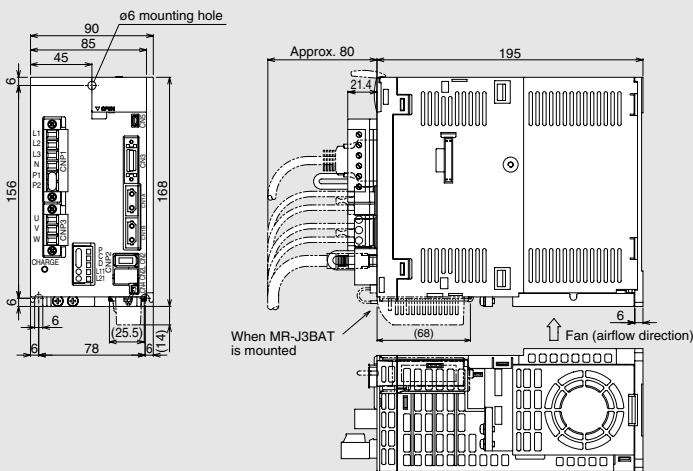

< Terminal arrangement >

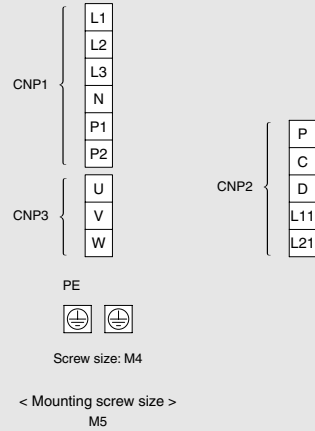

## ● MR-J3-200B4 (Note)

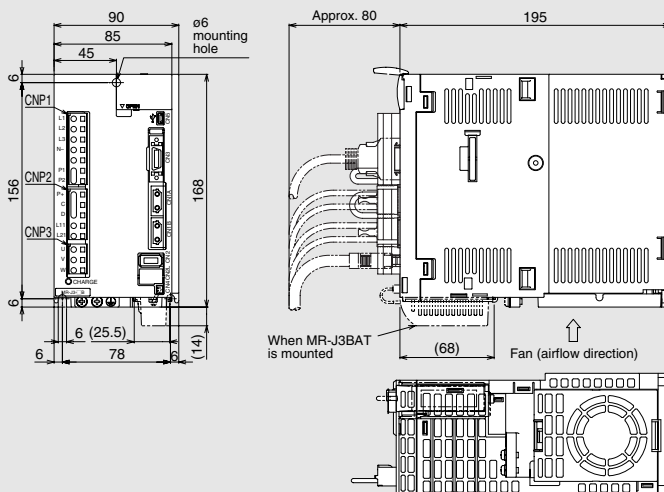

< Terminal arrangement >

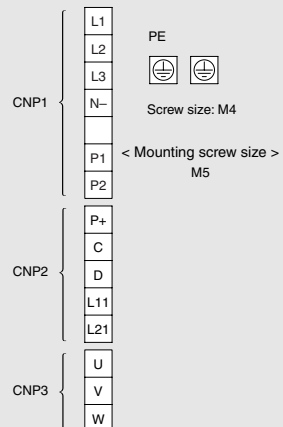

Note: The connectors CNP1, CNP2 and CNP3 (insertion type) are supplied with the servo amplifier.



# Drive Unit Dimensions

## MR-J3-DU□B(4)

(Unit: mm)

- MR-J3-DU30KB, DU37KB, DU45KB4, DU55KB4 (Note 2)

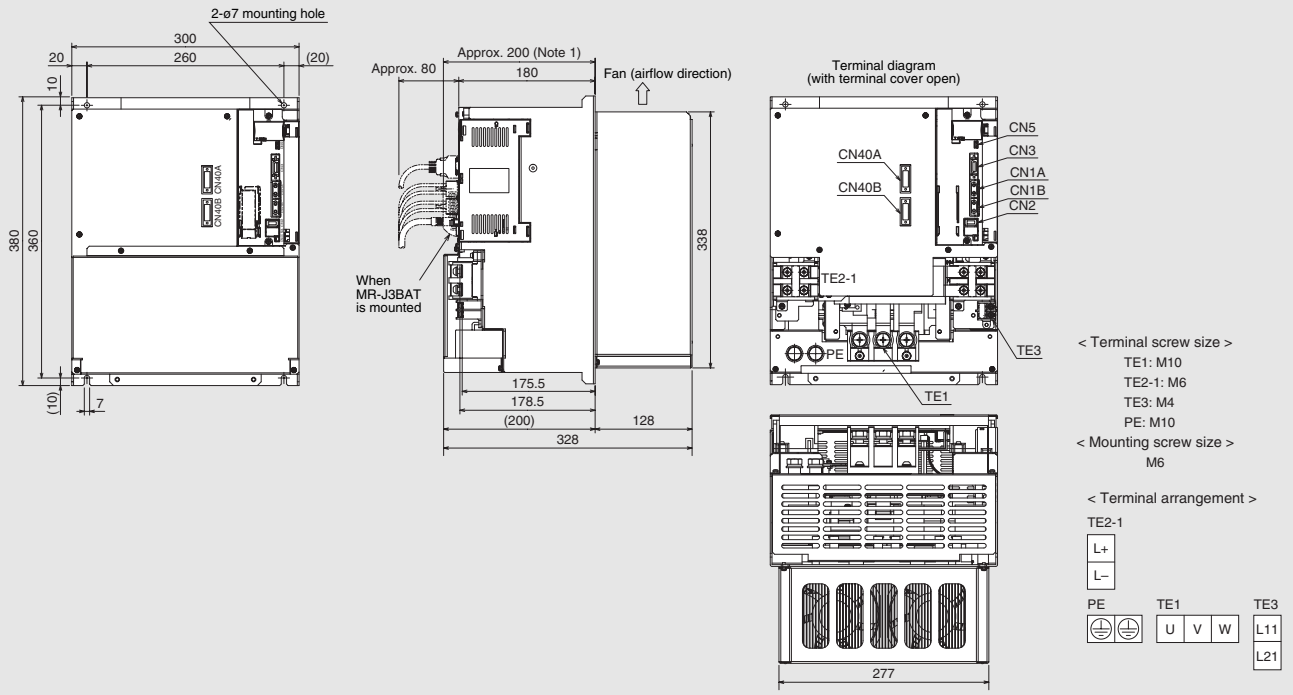

- MR-J3-DU30KB4, DU37KB4 (Note 2)

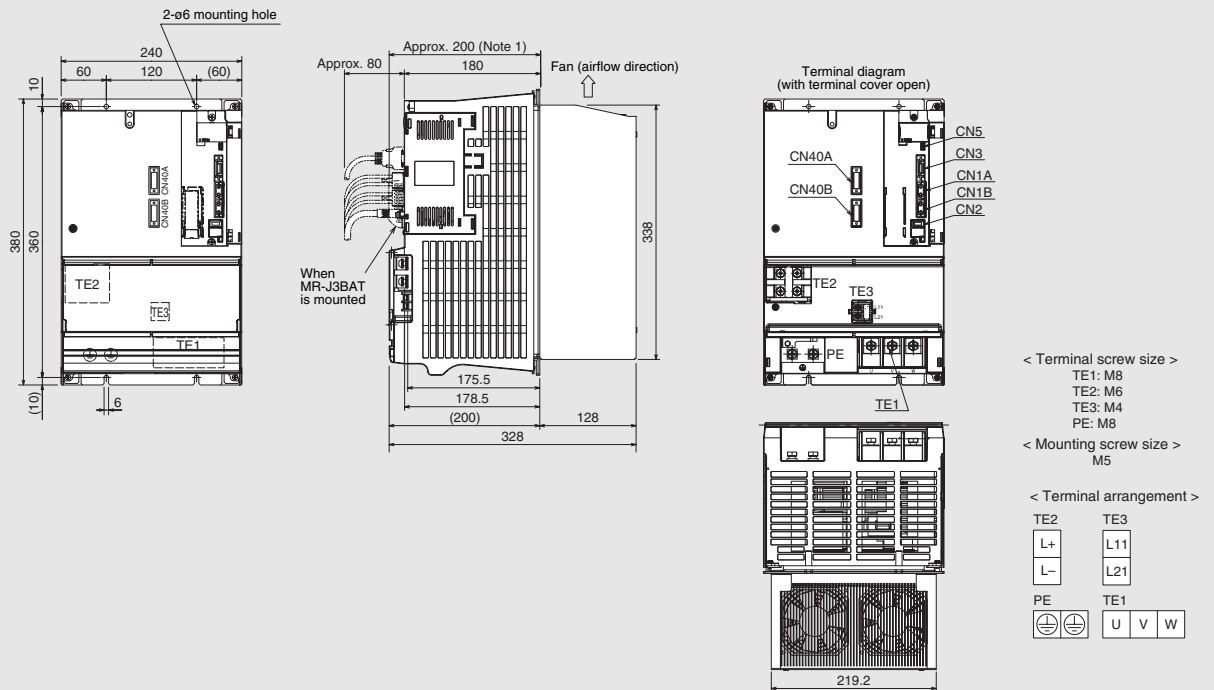

Notes: 1. The dimension applies when MR-J3BAT is mounted.

2. For the converter unit dimensions and the panel-cut dimensions for the converter unit and the drive unit, refer to the section "Converter unit dimensions".

# Features/System Configuration (MR-J3-B-RJ006)

Retaining the high performance, high functionality and usability of the MELSERVO-J3 Series, MR-J3-B-RJ006 is able to read position feedback signals from a load-side encoder such as a linear encoder. MR-J3-B-RJ006 has realized less installation space and less wiring as compared to the MR-J2S Series.



## Features: MR-J3-B-RJ006 (Fully closed loop control compatible)

- High accuracy position control is possible with the fully closed loop system.
- Dual feedback control provides the highest possible positioning response by using the position feedback signals from the motor encoder during high-speed rotation, and from the load-side encoder, such as a linear encoder, when positioning (stopping).
- High-speed, high-accuracy and high-reliability system can be configured with a serial interface linear encoder for MELSERVO-J3 Series.
- Absolute position detection system is easily structured without a battery by using an absolute type linear encoder with compatible serial interface.

### <Simple overview of Dual feedback control block>

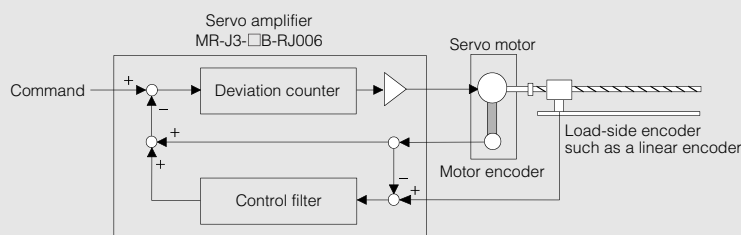

## System configurations

Fully closed loop control system can be easily structured by connecting the encoder to the CN2L connector (load-side encoder interface). Select a load-side encoder in accordance with the following:

$$4096(2^{12}) \leq \text{the number of the load-side encoder pulses per servo motor rotation} \leq 67108864(2^{26})$$

### (1) When using a linear encoder with compatible serial interface or ABZ phase pulse train interface (Note 3):

Applicable for the absolute position detection system when an absolute type encoder is used. The battery (MR-J3BAT) is not required. For linear encoders, refer to the section "MR-J3-□B-□-RJ006 compatible linear encoders" on page 67 in this catalog.

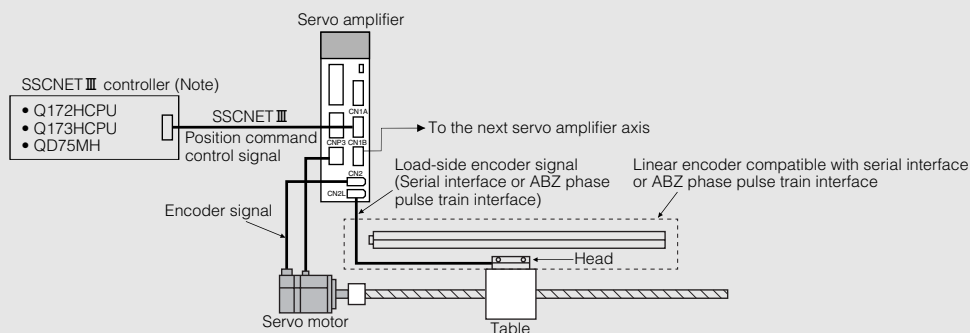

### (2) When using a rotary encoder with compatible ABZ phase pulse train interface:

Not applicable for the absolute position detection system.

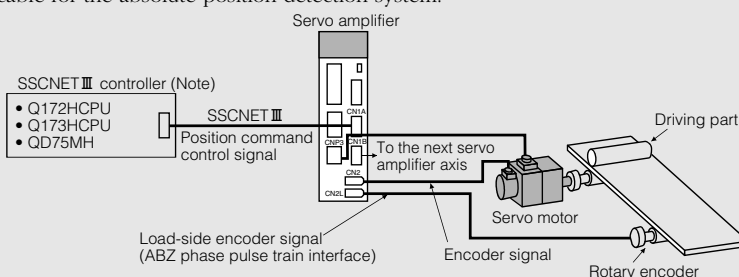

Note: For details on the controllers, refer to relevant programming manual or user's manual.



# Fully Closed Loop Diagnostic Functions

## Fully closed loop diagnostic functions of MR Configurator (Setup software)

With the fully closed loop diagnostic functions, monitoring and reading/writing of parameters related to the fully closed loop function are possible.

### [Fully closed diagnostics] window

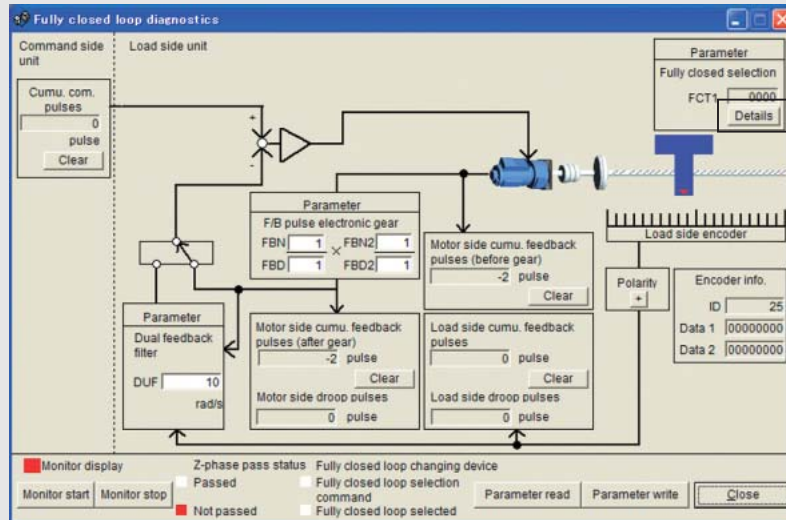

### [Parameter-Fully closed selection] window

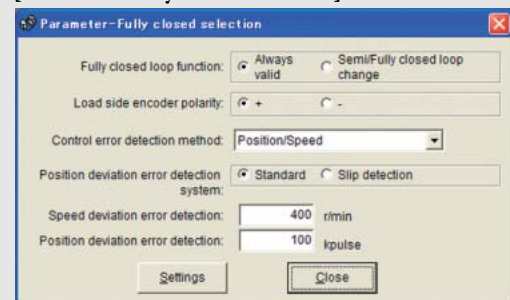

Note: The screens shown on this page are for reference and may differ from the actual screens.

### ● Items displayed in the [Fully closed diagnostics] window

Item	Description
Cumu. com. pulses	Counts and displays the position command input pulses. Resets to 0 by pressing the "Clear" button.
Motor side cumu. feedback pulses (before gear)	Counts and displays the feedback pulses from the servo motor encoder. (Motor encoder unit) Resets to 0 by pressing the "Clear" button.
Motor side cumu. feedback pulses (after gear)	Counts and displays the feedback pulses from the servo motor encoder. (Load-side encoder unit) Resets to 0 by pressing the "Clear" button.
Load side cumu. feedback pulses	Counts and displays the feedback pulses from the load-side encoder. Resets to 0 by pressing the "Clear" button.
Motor side droop pulses	Displays the difference between the motor-side position and the commanded position.
Load side droop pulses	Displays the difference between the load-side position and the commanded position.
Polarity	Displays "+" or "-" according to the load-side encoder polarity.
Encoder info.	Displays information about the load-side encoder. The displayed items vary depending on the type of the load-side encoder.
Z-phase pass status	Displays Z-phase pass status of the motor encoder when the fully closed loop system is "Invalid". Displays Z-phase pass status of the load-side encoder when the fully closed loop system is "Valid" or in "Semi closed loop control/Fully closed loop switching".
Fully closed loop changing device	Displays only when "Semi closed loop control/Fully closed loop control switching" is selected for the fully closed loop system. Displays state of the Semi closed loop control/Fully closed loop control switching bit and internal state selected.
Monitor display	Starts monitoring by pressing the "Monitor start" button. Stops monitoring by pressing the "Monitor stop" button.
Parameter read	Reads all parameters displayed on the window from the servo amplifier and displays them.
Parameter write	Writes all parameters displayed on the window into the servo amplifier.

### ● Items displayed in the [Parameter-Fully closed selection] window

Displays the [Parameter-Fully closed selection] window by pressing the "Details" button in the [Fully closed diagnostics] window.

Item	Description
Fully closed loop function	Selects the fully closed loop function from "Always valid" or "Semi/Fully closed loop change". When using this function, validate the fully closed loop system with the parameter No. PA01.
Load side encoder polarity	Selects the load-side encoder polarity with "+" or "-".
Control error detection method	Selects the fully closed loop control error detection method.
Position deviation error detection system	Selects the detection system regarding to the position deviation error of the fully closed loop control error detection function.
Speed deviation error detection	Specifies the speed deviation error detection level used in the fully closed loop control error detection function.
Position deviation error detection	Specifies the position deviation error detection level used in the fully closed loop control error detection function.

# Amplifier Specifications



## MR-J3-B-RJ006 servo amplifier specifications: 100VAC/200VAC

Servo amplifier model MR-J3-□-RJ006		10B	20B	40B	60B	70B	100B	200B	350B	500B	700B	11KB	15KB	22KB	10B1	20B1	40B1	
Main circuit power supply	Voltage/frequency (Note 1, 2)	3-phase 200 to 230VAC 50/60Hz or 1-phase 200 to 230VAC 50/60Hz (Note 10)					3-phase 200 to 230VAC 50/60Hz							1-phase 100 to 120VAC 50/60Hz				
	Permissible voltage fluctuation	For 3-phase 200 to 230VAC: 3-phase 170 to 253VAC For 1-phase 200 to 230VAC: 1-phase 170 to 253VAC					3-phase 170 to 253VAC							1-phase 85 to 132VAC				
	Permissible frequency fluctuation	±5% maximum																
Control circuit power supply	Voltage/frequency	1-phase 200 to 230VAC 50/60Hz (Note 10)					1-phase 200 to 230VAC 50/60Hz							1-phase 100 to 120VAC 50/60Hz				
	Permissible voltage fluctuation	1-phase 170 to 253VAC																
	Permissible frequency fluctuation	±5% maximum																
	Power consumption (W)	30					45					30						
Interface power supply		24VDC ±10% (required current capacity: 150mA (Note 7))																
Load-side encoder interface	Serial interface		Mitsubishi high-speed serial communication															
	Pulse train interface	Input signal	ABZ phase differential input signal															
		Minimum phase difference	200ns															
Regenerative resistor/ tolerable regenerative power (W) (Note 3, 4)	Built-in regenerative resistor		—	10	10	10	20	20	100	100	130	170	—	—	—	—	10	10
	External regenerative resistor (Standard accessory) (Note 5, 6)		—	—	—	—	—	—	—	—	—	—	500 (800)	850 (1300)	850 (1300)	—	—	—
Control system		Sine-wave PWM control/current control system																
Dynamic brake		Built-in (Note 8)										External option		Built-in (Note 8)				
Safety features		Overcurrent shutdown, regeneration overvoltage shutdown, overload shutdown (electronic thermal), servo motor overheat protection, encoder fault protection, regeneration fault protection, undervoltage/sudden power outage protection, overspeed protection, excess error protection																
Structure		Self-cooling open (IP00)					Fan cooling open (IP00)							Self-cooling open (IP00)				
Environment	Ambient temperature (Note 9)		0 to 55°C (32 to 131°F) (non freezing), storage: -20 to 65°C (-4 to 149°F) (non freezing)															
	Ambient humidity		90% RH maximum (non condensing), storage: 90% RH maximum (non condensing)															
	Atmosphere		Indoors (no direct sunlight); no corrosive gas, inflammable gas, oil mist or dust															
	Elevation		1000m or less above sea level															
	Vibration		5.9m/s <sup>2</sup> maximum															
Mass (kg [lb])		0.8 (1.8)	0.8 (1.8)	1.0 (2.2)	1.0 (2.2)	1.4 (3.1)	1.4 (3.1)	2.3 (5.1)	2.3 (5.1)	4.6 (10)	6.2 (14)	18 (40)	18 (40)	19 (42)	0.8 (1.8)	0.8 (1.8)	1.0 (2.2)	

Notes: 1. Rated output and rated speed of the servo motor used in combination with the servo amplifier are as indicated when using the power supply voltage and frequency listed. The torque drops when the power supply voltage is less than specified.

2. For torque characteristics when combined with a servo motor, refer to the section "Servo motor torque characteristics" in this catalog.

3. Optimal regenerative resistor varies for each system.

4. Refer to the section "Options ●Optional regeneration unit" in this catalog for the tolerable regenerative power (W).

5. The servo amplifier (MR-J3-□KB-RZ006) without an enclosed regenerative resistor is also available.

6. The value applies when the external regenerative resistors, GRZG400-□Ω, (standard accessory) are used with cooling fans (2 units of 92 × 92mm, minimum air flow: 1.0m<sup>3</sup>/min). Note that change in the parameter No. PA02 is required.

7. 150mA is the value when all of the input/output points are used. The current capacity can be stepped down according to the number of input/output points in use. Refer to "MR-J3-□B-RJ006 SERVO AMPLIFIER INSTRUCTION MANUAL" for details.

8. Special specification models without a dynamic brake, MR-J3-□B-RU006 and MR-J3-□B1-RU006, are also available.

9. The MR-J3-350B or smaller servo amplifier can be installed closely. In this case, keep the ambient temperature within 0 to 45°C (32 to 113°F), or use the servo amplifier with 75% or less of the effective load rate.

10. The special specification model, MR-J3-□B-RJ006U004, is also available for 1-phase 200 to 240VAC.

# Amplifier Specifications



## MR-J3-B-RJ006 servo amplifier specifications: 400VAC

Servo amplifier model MR-J3-□-RJ006		60B4	100B4	200B4	350B4	500B4	700B4	11KB4	15KB4	22KB4	
Main circuit power supply	Voltage/frequency (Note 1, 2)	3-phase 380 to 480VAC 50/60Hz									
	Permissible voltage fluctuation	3-phase 323 to 528VAC									
	Permissible frequency fluctuation	±5% maximum									
Control circuit power supply	Voltage/frequency	1-phase 380 to 480VAC 50/60Hz									
	Permissible voltage fluctuation	1-phase 323 to 528VAC									
	Permissible frequency fluctuation	±5% maximum									
	Power consumption (W)	30			45						
Interface power supply		24VDC ±10% (required current capacity: 150mA (Note 7))									
Load-side encoder interface	Serial interface		Mitsubishi high-speed serial communication								
	Pulse train interface	Input signal	ABZ phase differential input signal								
		Minimum phase difference	200ns								
Regenerative resistor/ tolerable regenerative power (W) (Note 3, 4)	Built-in regenerative resistor		15	15	100	100	130 (Note 9)	170 (Note 9)	—	—	—
	External regenerative resistor (Standard accessory) (Note 5, 6)		—	—	—	—	—	—	500 (800)	850 (1300)	850 (1300)
Control system		Sine-wave PWM control/current control system									
Dynamic brake		Built-in (Note 8, 10)						External option			
Safety features		Overcurrent shutdown, regeneration overvoltage shutdown, overload shutdown (electronic thermal), servo motor overheat protection, encoder fault protection, regeneration fault protection, undervoltage/sudden power outage protection, overspeed protection, excess error protection									
Structure		Self-cooling open (IP00)			Fan cooling open (IP00)						
Environment	Ambient temperature		0 to 55°C (32 to 131°F) (non freezing), storage: -20 to 65°C (-4 to 149°F) (non freezing)								
	Ambient humidity		90% RH maximum (non condensing), storage: 90% RH maximum (non condensing)								
	Atmosphere		Indoors (no direct sunlight); no corrosive gas, inflammable gas, oil mist or dust								
	Elevation		1000m or less above sea level								
	Vibration		5.9m/s <sup>2</sup> maximum								
Mass (kg [lb])		1.7 (3.7)	1.7 (3.7)	2.1 (4.6)	4.6 (10)	4.6 (10)	6.2 (14)	18 (40)	18 (40)	19 (42)	

- Notes: 1. Rated output and rated speed of the servo motor used in combination with the servo amplifier are as indicated when using the power supply voltage and frequency listed. The torque drops when the power supply voltage is less than specified.
2. For torque characteristics when combined with a servo motor, refer to the section "Servo motor torque characteristics" in this catalog.
3. Optimal regenerative resistor varies for each system.
4. Refer to the section "Options ●Optional regeneration unit" in this catalog for the tolerable regenerative power (W).
5. The servo amplifier (MR-J3-□KB4-RZ006) without an enclosed regenerative resistor is also available.
6. The value applies when the external regenerative resistors, GRZG400-□Ω, (standard accessory) are used with cooling fans (2 units of 92 × 92mm, minimum air flow: 1.0m<sup>3</sup>/min). Note that change in the parameter No. PA02 is required.
7. 150mA is the value when all of the input/output points are used. The current capacity can be stepped down according to the number of input/output points in use. Refer to "MR-J3-□B-RJ006 SERVO AMPLIFIER INSTRUCTION MANUAL" for details.
8. Special specification models without a dynamic brake, MR-J3-□B4-RU006, are also available.
9. The amplifier built-in resistor is compatible with the maximum torque deceleration when the motor is used within the rated speed and the recommended load/motor inertia moment ratio. Contact Mitsubishi if the operating motor speed and the load/motor inertia moment ratio exceed the rated speed and the recommended ratio.
10. For the servo amplifier 5kW or 7kW, the load/motor of inertia moment ratio must be 5 times or less when the amplifier built-in dynamic brake is used, and the motor speed exceeds 2000r/min.

# Standard Wiring Diagram

## Connector CN2L connection examples

(11) MR-J3-□B(1)/(4)-RJ006

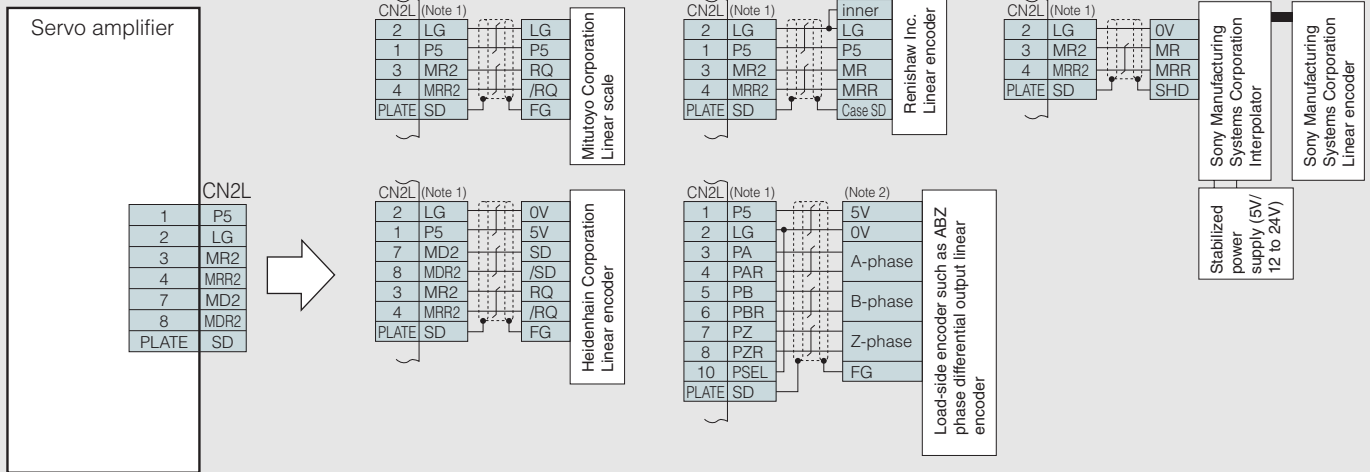

Notes: 1. When manufacturing the linear encoder connection cable, use the optional CN2L connector (MR-J3CN2). Refer to "MR-J3-□B-RJ006 SERVO AMPLIFIER INSTRUCTION MANUAL" for details on the wiring.  
2. If the encoder's current consumption exceeds 350mA, supply power from an external source.

## MR-J3-□B□-RJ006 compatible linear encoders

### ● List of compatible linear encoders (Note 1)

Linear encoder type	Manufacturer	Model	Resolution	Rated speed (Note 2)	Effective measurement length (maximum)	Communication method	Position system	
Mitsubishi serial interface compatible	Mitutoyo Corporation	AT343A	0.05μm	2.0m/s	3000mm	2-wire type	Absolute	
		AT543A-SC		2.5m/s	2200mm			
		ST741A	0.5μm	4.0m/s	6000mm			
		ST743A (Note 5)	0.1μm					
	Heidenhain Corporation	LC491M	0.05μm/ 0.01μm	2.0m/s	2040mm	4-wire type		
		LC192M		3.0m/s	4240mm			
	Mitsubishi serial interface compatible	Sony Manufacturing Systems Corporation	SL710+PL101-R/RH +MJ830 or MJ831	0.2μm (Note 3)	6.4m/s	3000mm	2-wire type	Incremental
			SH13 +MJ830 or MJ831	0.005μm (Note 3)	1.4m/s	1240mm		
Renishaw Inc.		RGH26P	5μm	4.0m/s	70000mm			
		RGH26Q	1μm	3.2m/s				
		RGH26R	0.5μm	1.6m/s				
Heidenhain Corporation		LIDA485+APE391M	0.005μm (20/4096μm)	4.0m/s	30040mm	4-wire type		
	LIDA487+APE391M	6040mm						
ABZ phase differential output type (Note 4)	Incremental type	Not designated	-	Within tolerable resolution range	Depends on linear encoder	Depends on linear encoder	Differential 3-pair type	

Notes: 1. Consult with the linear encoder manufacturers for details on the linear encoder's working environment and specifications such as ambient temperature, vibration resistance and protection level. Also, contact the manufacturer when using the linear encoder in high electrostatic noise environment.  
2. The indicated values are the linear encoder's rated speed when used in combination with the Mitsubishi fully closed loop compatible servo amplifier. The values may differ from the manufacturers' specifications.  
3. The resolution differs according to the setting value of the interpolator, MJ830/MJ831 manufactured by Sony Manufacturing Systems Corporation.  
4. Output the A-phase, B-phase and Z-phase signals in the differential line driver. The phase difference of A-phase pulse and B-phase pulse, and the width of Z-phase pulse must be 200ns or wider. Zero point return is not possible with a linear encoder which is not equipped with a Z-phase.  
5. The servo amplifier software version A1 or above is compatible with this linear scale.

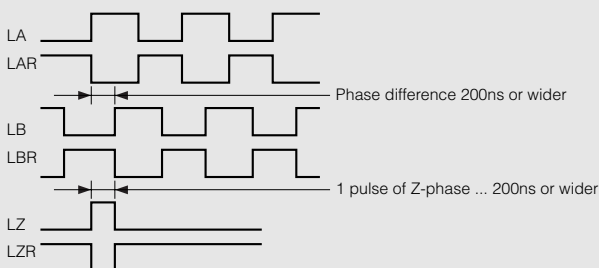

# Amplifier Dimensions

## MR-J3-□B□-RJ006

(Unit: mm)

- MR-J3-10B-RJ006, 20B-RJ006, 10B1-RJ006, 20B1-RJ006 (Note)

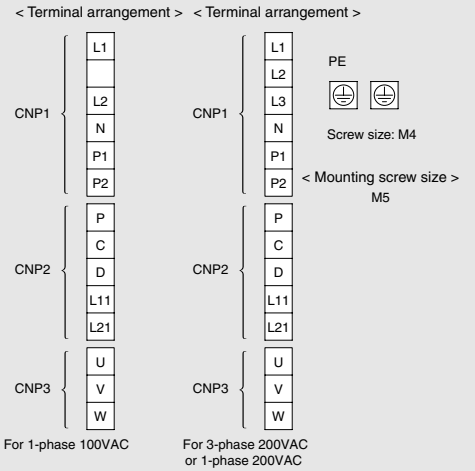
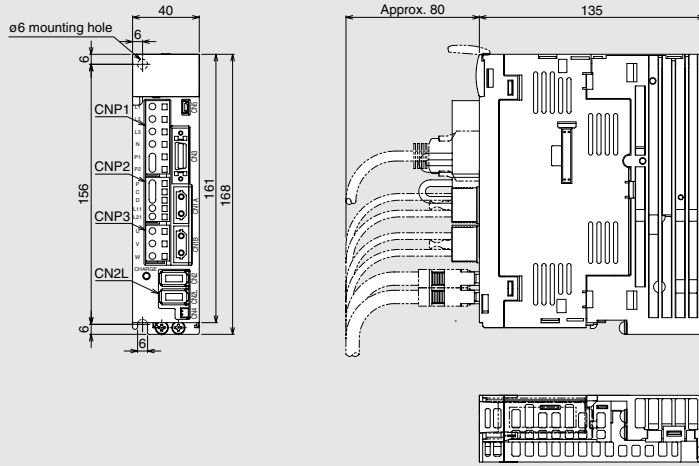

- MR-J3-40B-RJ006, 60B-RJ006, 40B1-RJ006 (Note)

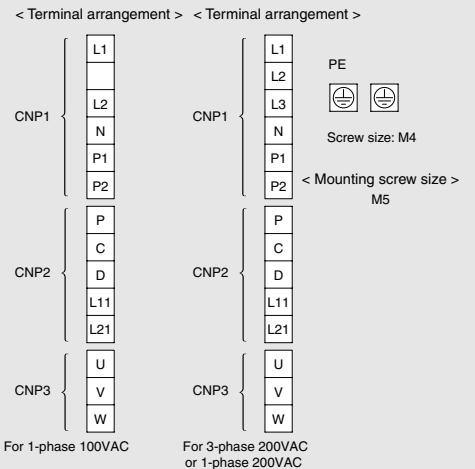
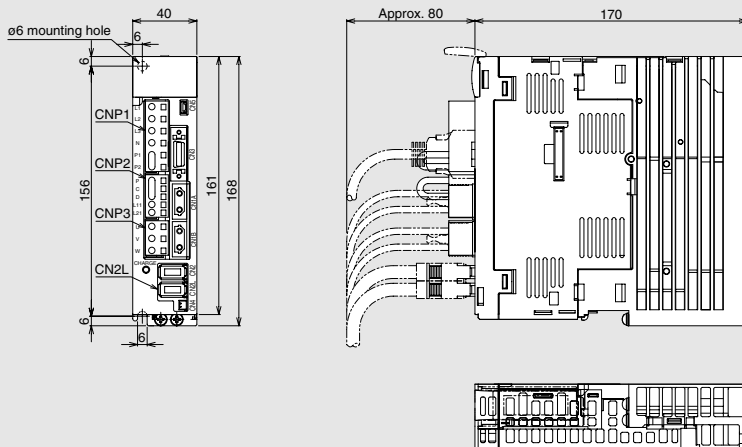

- MR-J3-70B-RJ006, 100B-RJ006 (Note)

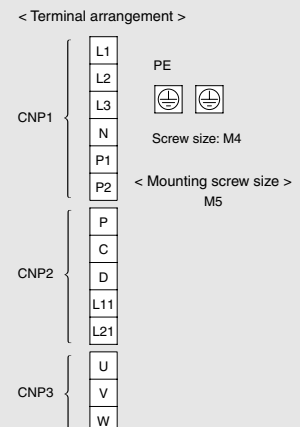
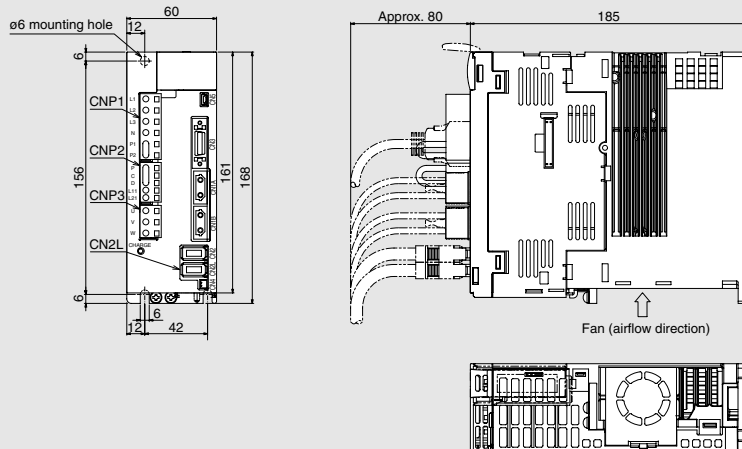

Note: The connectors CNP1, CNP2 and CNP3 (insertion type) are supplied with the servo amplifier.

# Amplifier Dimensions

(Unit: mm)

## ● MR-J3-60B4-RJ006, 100B4-RJ006 (Note)

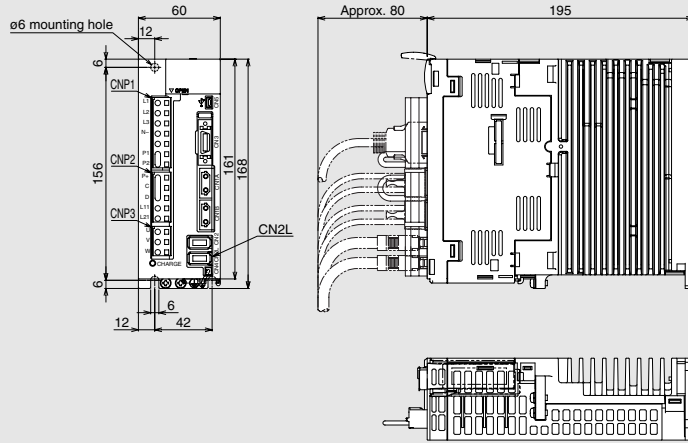

< Terminal arrangement >

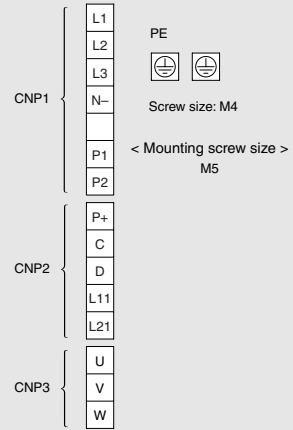

## ● MR-J3-200B-RJ006, 350B-RJ006 (Note)

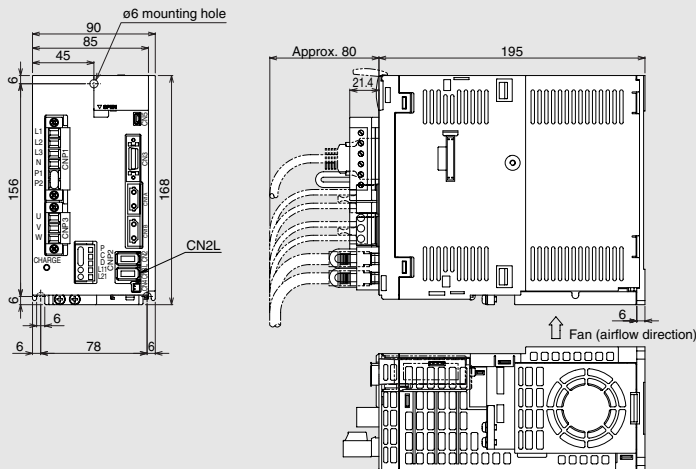

< Terminal arrangement >

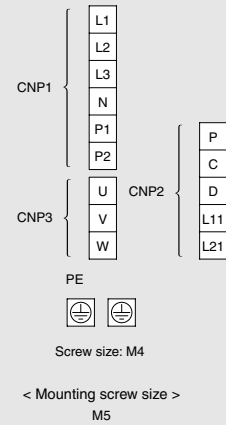

## ● MR-J3-200B4-RJ006 (Note)

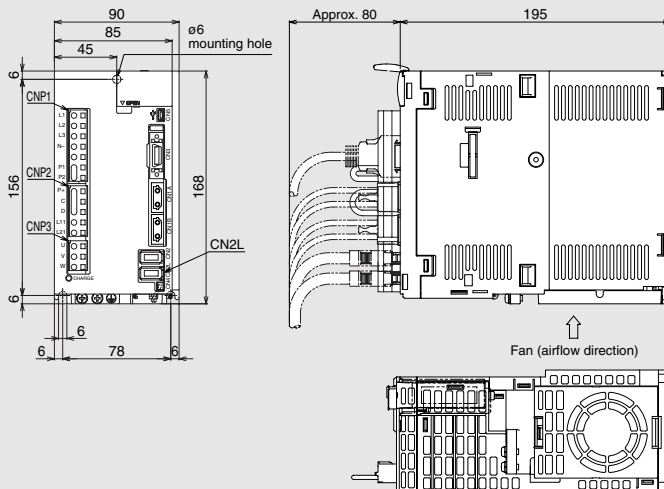

< Terminal arrangement >

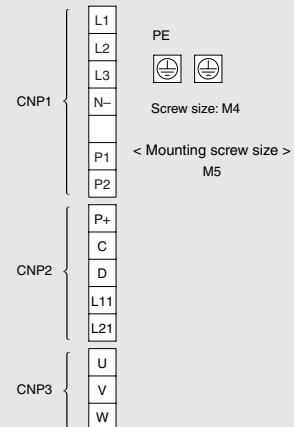

# Amplifier Dimensions

(Unit: mm)

## ● MR-J3-500B-RJ006, 350B4-RJ006, 500B4-RJ006

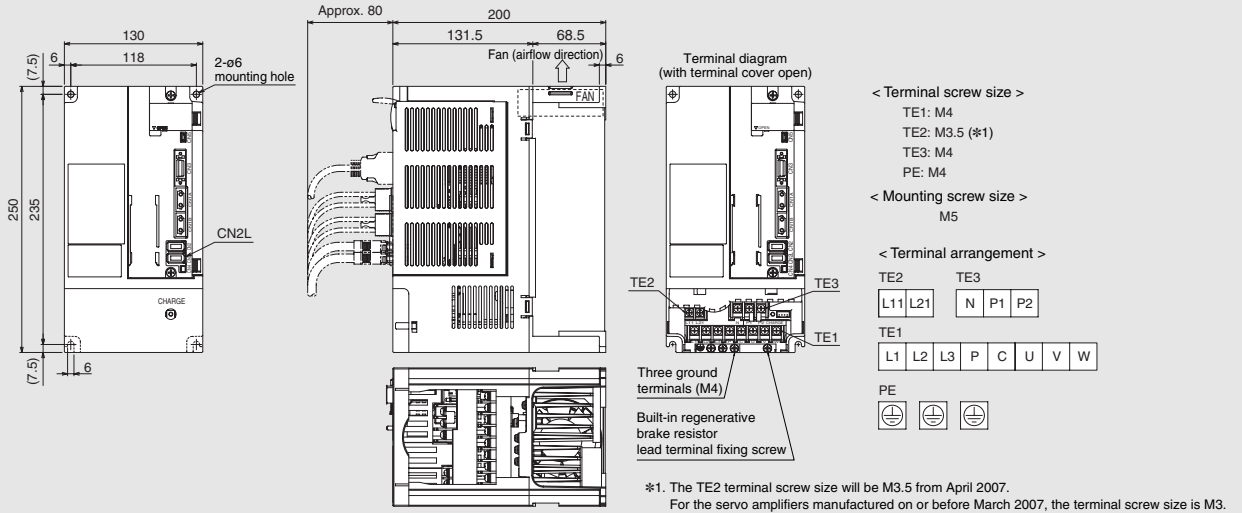

## ● MR-J3-700B-RJ006, 700B4-RJ006

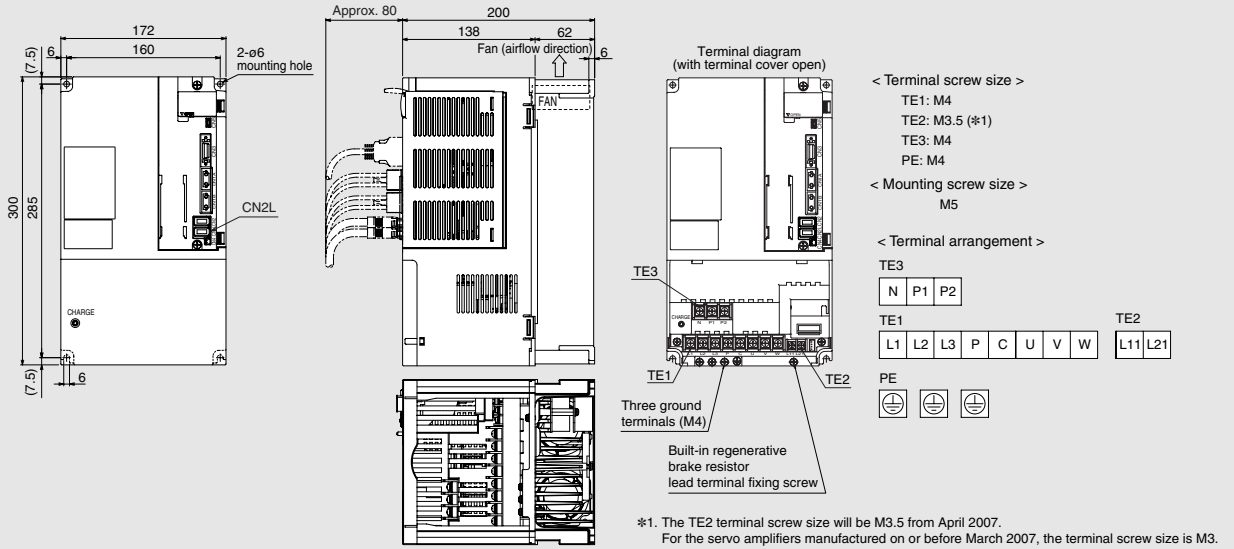

## ● MR-J3-11KB-RJ006 to 22KB-RJ006, 11KB4-RJ006 to 22KB4-RJ006

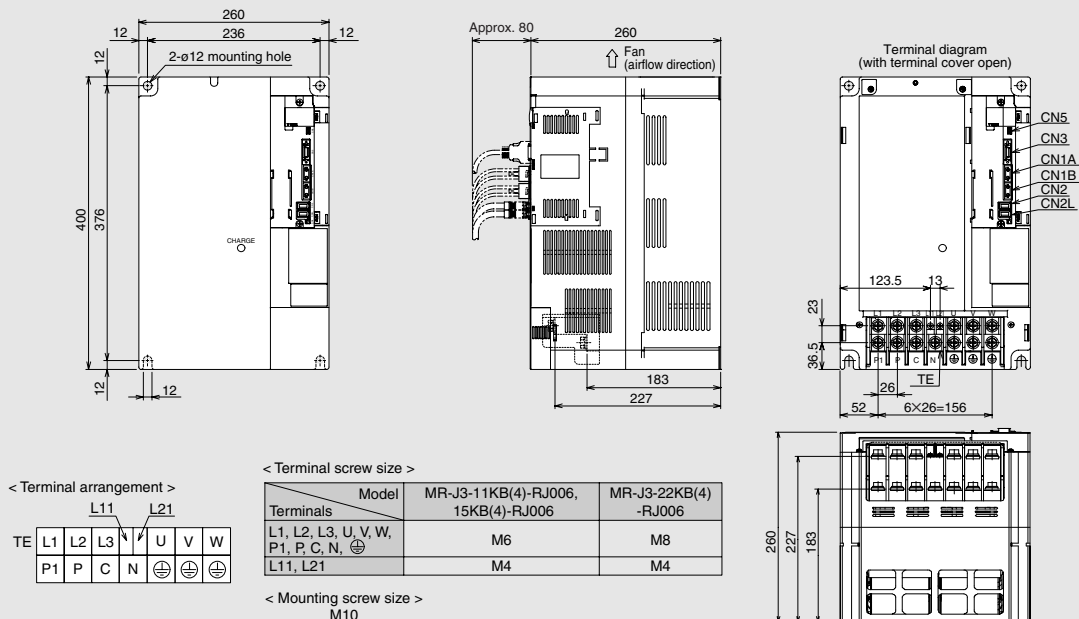

# Peripheral Equipment (MR-J3-T)

## Connections with peripheral equipment (Note 1)

Peripheral equipment is connected to MR-J3-T as described below.

Connectors, options, and other necessary equipment are available so that users can set up MR-J3-T easily and begin using it right away.

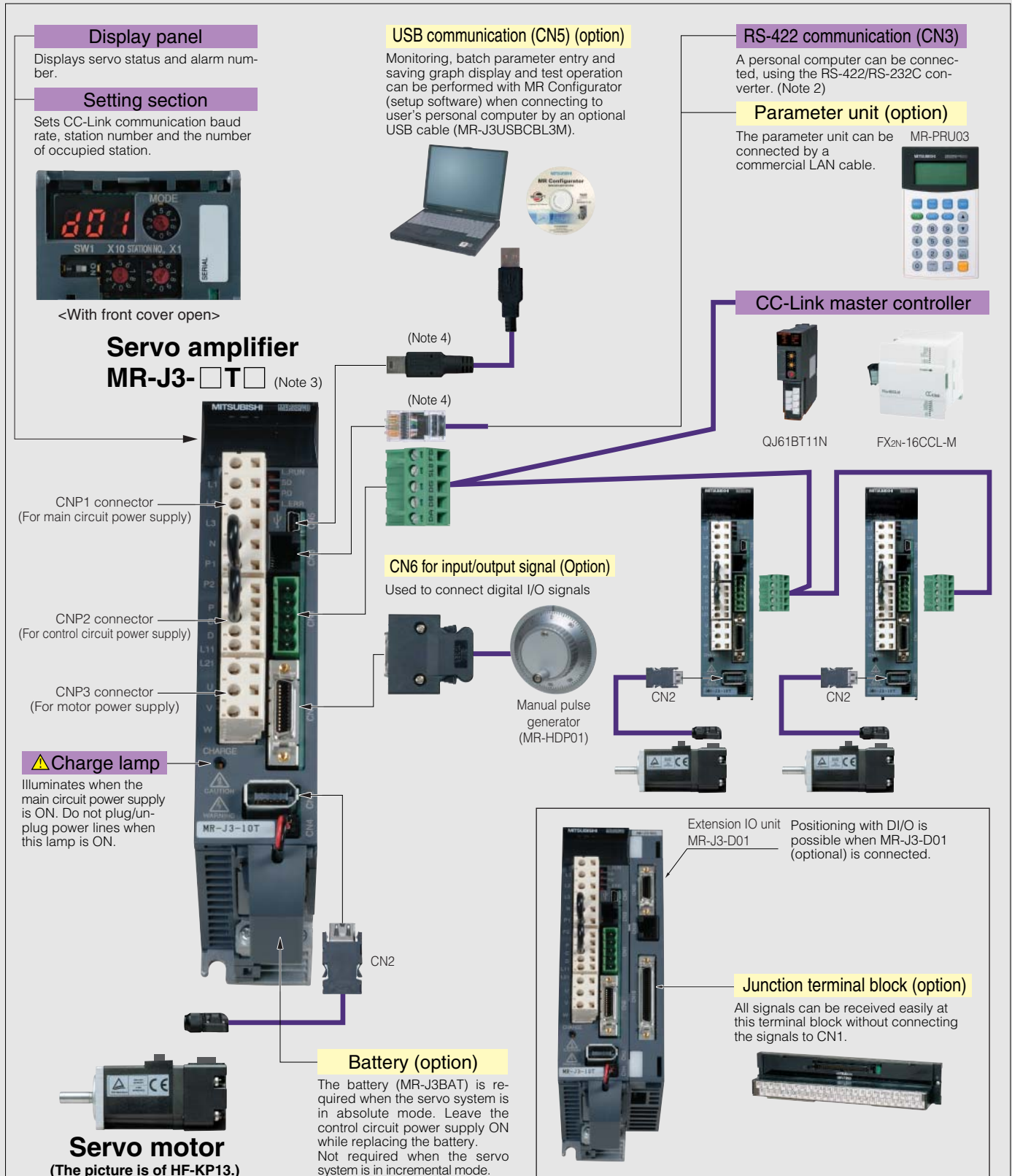

Notes: 1. Refer to "MR-J3-□T SERVO AMPLIFIER INSTRUCTION MANUAL" for the actual connections.

2. When a personal computer is connected using the RS-422/RS-232C conversion cable (refer to the section "Ordering Information for Customers" in this catalog), some functions of MR Configurator (setup software) may be limited.

3. The connections with peripheral equipment shown above is for MR-J3-350T or smaller servo amplifier.

4. USB interface (CN5 connector) and RS-422 interface (CN3 connector) are mutually exclusive. They cannot be used at the same time.



# Features (CC-Link Compatible Built-in Positioning function)

Positioning operation can be performed just by setting position data (target positions), servo motor speeds, and acceleration/deceleration time constant, etc. in the point tables as if setting them in parameters. The AC servo can be used as the field network's drive source. This servo amplifier is the most appropriate when simplifying a system or configuring a simple positioning system without programs. Also, by using MR Configurator (setup software) together with the servo amplifier, easier operation with advanced functions can be possible.

## Features: MR-J3-T (CC-Link compatible built-in positioning function)



- By using this servo amplifier with built-in positioning function, position and speed data, etc. can be set via CC-Link communication. (Applicable CC-Link version: Ver.1.10)
- Start, stop and monitor displays can be performed via CC-Link communication.
- Serial communication reduces wiring.
- CC-Link communication makes it possible to design the system with the servo amplifiers dispersed throughout.
- Parameter unit, MR-PRU03 (optional), makes parameter setting and operation monitoring easier.

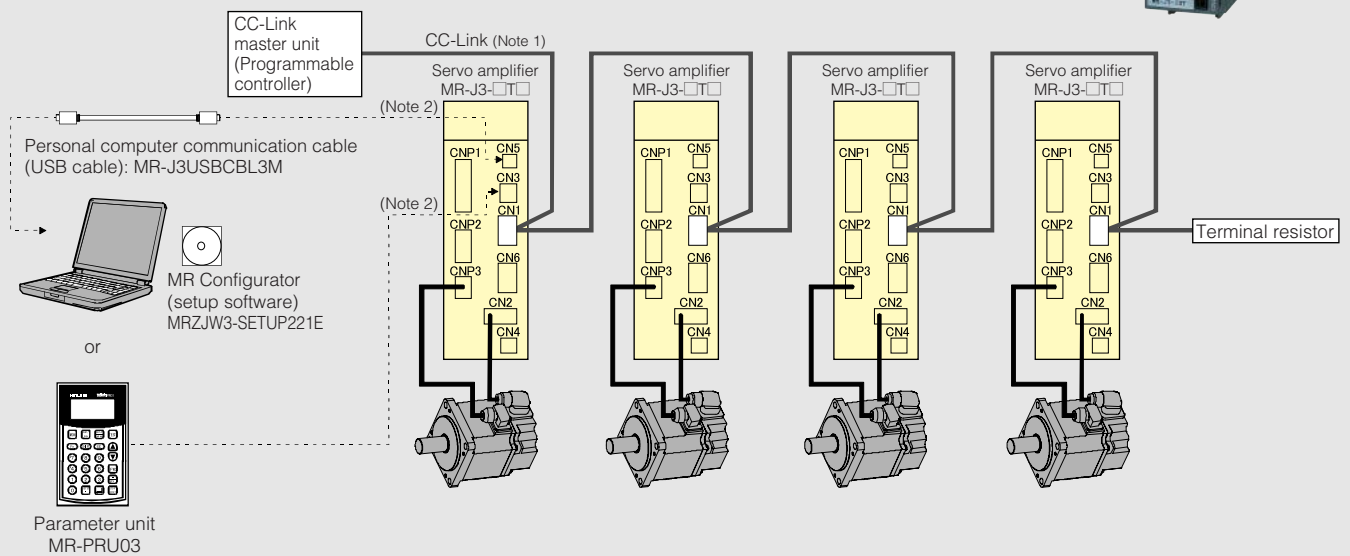

- Notes: 1. When using only remote device stations, up to 42 servo amplifiers can be connected when 1 station is occupied by 1 servo amplifier, and up to 32 servo amplifiers when 2 stations are occupied by 1 servo amplifier.  
 2. USB interface (CN5 connector) and RS-422 interface (CN3 connector) are mutually exclusive. They cannot be used at the same time.

# Features (CC-Link Compatible Built-in Positioning function)

## Features: MR-J3-T+MR-J3-D01 (DI/O command)

- Positioning with DI/O command is possible by using the extension IO unit, MR-J3-D01 (optional).  
(Total digital input: 34 points. Total digital output: 19 points.)
- Up to 255 point tables can be used.

### Simple positioning using DI/O

Positioning operation is performed with digital input/output signals.

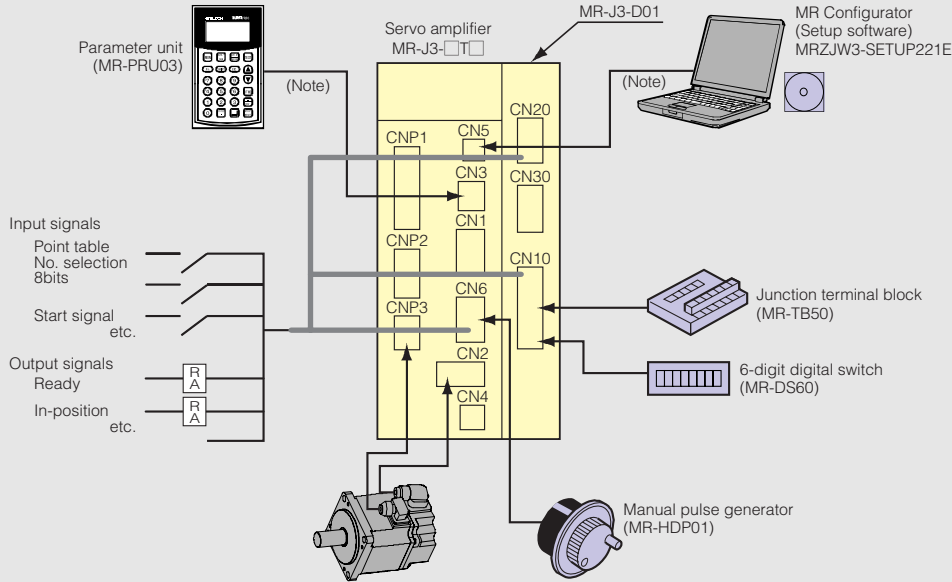

Note: USB interface (CN5 connector) and RS-422 interface (CN3 connector) are mutually exclusive. They cannot be used at the same time.

### Serial communication operation

Positioning operation is performed by connecting servo amplifiers in the multi-drop configuration.

The RS-422 protocol communication specifications are released, so the user can create a program.

The monitor and parameter settings can be made with the MR Configurator (setup software), MRZJW3-SETUP221E or above, using a personal computer.

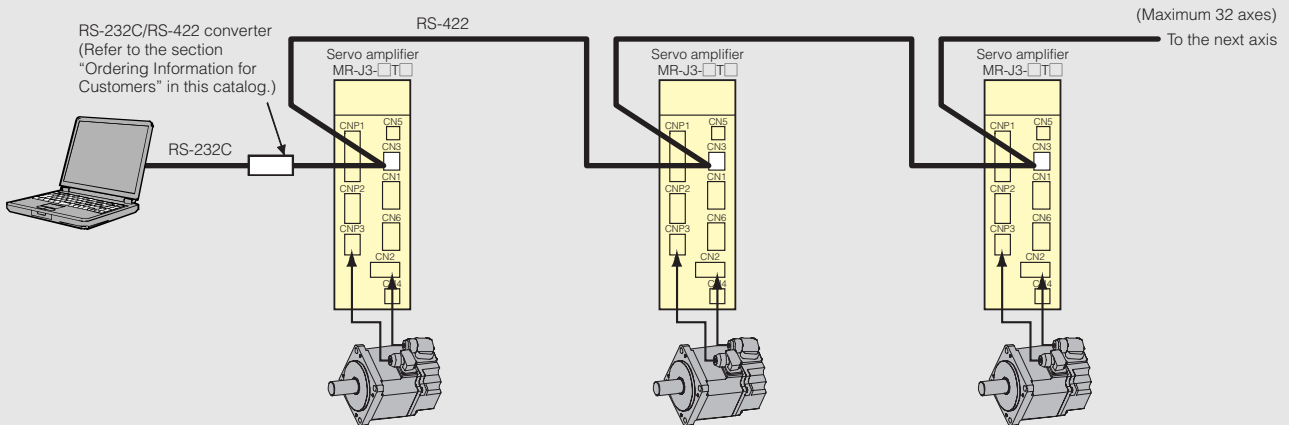

### Communications specifications

The RS-422 (RS-232C) specifications are as follows.

- Baud rate : 9600, 19200, 38400, 57600 or 115200 asynchronous.
- Transfer code : 1 start bit, 8 data bits, 1 parity bit (even number), 1 stop bit.
- Transfer protocol : Character system, half-duplex communication.

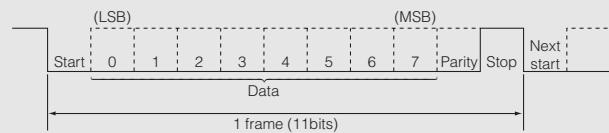

## MR-J3-T operational functions

### ● Roll feeding function

Capable of roll feeding operation (clear signal).  
Speed and acceleration/deceleration time constant, and override can be set.  
Position data can be set directly by remote register.

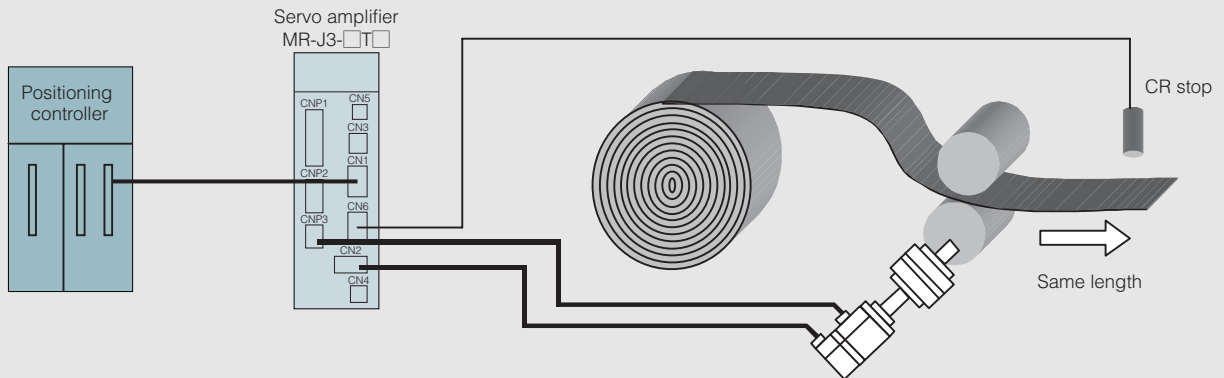

### ● Indexer function (available soon)

Positioning is performed by specifying stations (255 stations maximum).  
Automatic calculation can be carried out from the number of stations and gears on machine and motor side set with the parameters.

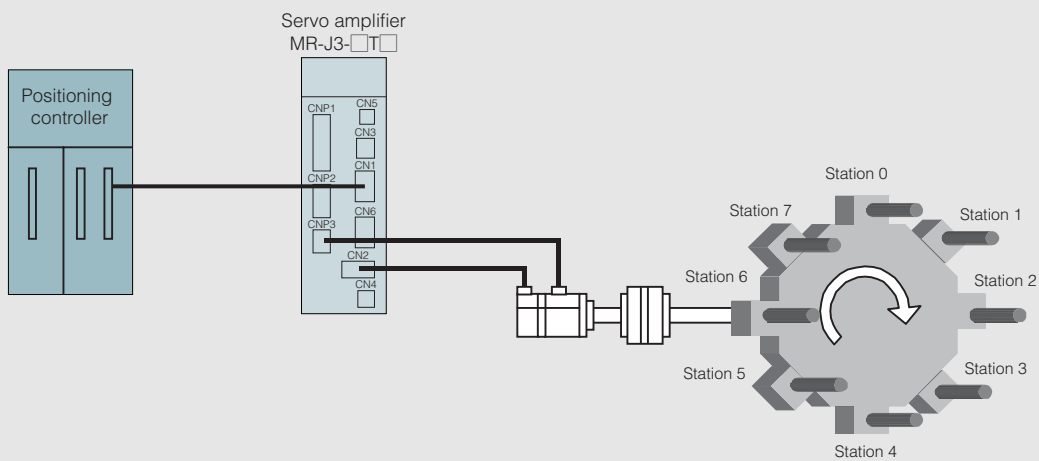

# Command Method

## MR-J3-T positioning command method

The following two types of command methods are available.

Remote register (Note)	Sets position data and servo motor speed data directly in the remote register, and then executes positioning.
Point table No. input	Specifies position data and servo motor speed data set previously with the point table No., and then executes positioning.

Note: Setting range and description of position and servo motor speed data for the remote register are same as for the point table. Refer to the Point table below.

**Point table:** The following two types of point tables are available.

### (1) Absolute value command method:

Moves to the address (absolute value) based on the home position.

Item	Setting range	Unit	Description
Position data	-999999 to 999999	$\times 10^{\text{STM}} \mu\text{m}$	<ul style="list-style-type: none"> <li><b>Absolute value command method</b> Sets the address. STM is the ratio to the data.</li> <li><b>Incremental value command method</b> Sets the movement amount. STM is the ratio to the data.</li> </ul>
Servo motor speed	0 to permissible	r/min	Sets the command speed for the servo motor used for positioning.
Acceleration time constant	0 to 20000	ms	Sets the acceleration time constant. (Note 2)
Deceleration time constant	0 to 20000	ms	Sets the deceleration time constant. (Note 2)
Dwell time	0 to 20000	ms	Runs the next point table after the set dwell time.
Auxiliary function	0 to 3	—	<ul style="list-style-type: none"> <li><b>Absolute value command method</b> 0: Positions and stops (waits for start signal). 1: Continues operation for the next point table without stopping.</li> <li><b>Incremental value command method</b> 2: Positions and stops (waits for start signal). 3: Continues operation for the next point table without stopping.</li> </ul>
M code (Note 1)	0 to 99	—	Sets output code when positioning completes.

### (Example of setting point table data)

Point table No.	Position data	Servo motor speed	Acceleration time constant	Deceleration time constant	Dwell time	Auxiliary function	M code
1	1000	2000	200	200	0	1	1
2	2000	1600	100	100	0	0	2
:	:	:	:	:	:	:	:
255	3000	3000	100	100	0	2	99

If the point table No.1's auxiliary function is 1 or 3, continuous positioning operation is carried out based on the point table as shown in the "●Auxiliary function 1 or 3" below.  
If the point table No.1's auxiliary function is 0 or 2, a start signal must be issued as shown in "●Auxiliary function 0 or 2" below.

#### ●Auxiliary function 1 or 3

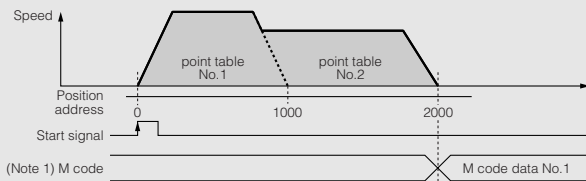

#### ●Auxiliary function 0 or 2

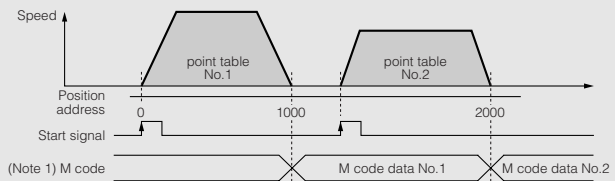

### (2) Incremental value command method:

Moves from the current value according to the set position data

Item	Setting range	Unit	Description
Position data	0 to 999999	$\times 10^{\text{STM}} \mu\text{m}$	Sets the movement amount.
Servo motor speed	0 to permissible	r/min	Sets the command speed for the servo motor used for positioning.
Acceleration time constant	0 to 20000	ms	Sets the acceleration time constant. (Note 2)
Deceleration time constant	0 to 20000	ms	Sets the deceleration time constant. (Note 2)
Dwell time	0 to 20000	ms	Runs the next point table after the set dwell time.
Auxiliary function	0 and 1	—	0: Positions and stops (waits for start signal). 1: Continues operation for the next point table without stopping.
M code (Note 1)	0 to 99	—	Sets output code when positioning completes.

### (Example of setting point table data)

Point table No.	Position data	Servo motor speed	Acceleration time constant	Deceleration time constant	Dwell time	Auxiliary function	M code
1	1000	2000	200	200	0	1	1
2	1000	1600	100	100	0	0	2
:	:	:	:	:	:	:	:
255	500	3000	100	100	0	0	99

If the point table No.1's auxiliary function is 1, continuous positioning operation is carried out based on the point table as shown in the "●Auxiliary function 1" below.  
If the point table No.1's auxiliary function is 0, a start signal must be issued as shown in "●Auxiliary function 0" below.

#### ●Auxiliary function 1

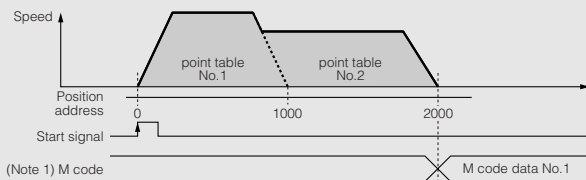

#### ●Auxiliary function 0

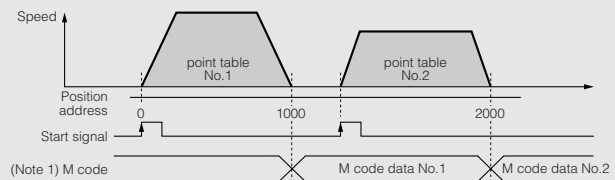

Notes: 1. When using M code, the extension IO unit MR-J3-D01 (optional) is required. M code is digitally-output from MR-J3-D01. Remote output is not possible.  
2. S-pattern acceleration/deceleration time constant is set by parameters.

# Amplifier Specifications



## MR-J3-T servo amplifier specifications: 100VAC/200VAC

Servo amplifier model MR-J3-		10T	20T	40T	60T	70T	100T	200T	350T	500T	700T	11KT	15KT	22KT	10T1	20T1	40T1	
Main circuit power supply	Voltage/frequency (Note 1, 2)	3-phase 200 to 230VAC 50/60Hz or 1-phase 200 to 230VAC 50/60Hz (Note 10)						3-phase 200 to 230VAC 50/60Hz						1-phase 100 to 120VAC 50/60Hz				
	Permissible voltage fluctuation	For 3-phase 200 to 230VAC: 3-phase 170 to 253VAC For 1-phase 200 to 230VAC: 1-phase 170 to 253VAC						3-phase 170 to 253VAC						1-phase 85 to 132VAC				
	Permissible frequency fluctuation	±5% maximum																
Control circuit power supply	Voltage/frequency	1-phase 200 to 230VAC 50/60Hz (Note 10)						1-phase 200 to 230VAC 50/60Hz						1-phase 100 to 120VAC 50/60Hz				
	Permissible voltage fluctuation	1-phase 170 to 253VAC																
	Permissible frequency fluctuation	±5% maximum																
	Power consumption (W)	30						45						30				
Interface power supply		24VDC ±10% (required current capacity: 150mA (Note 7))																
Regenerative resistor/ tolerable regenerative power (W) (Note 3, 4)	Built-in regenerative resistor	—	10	10	10	20	20	100	100	130	170	—	—	—	—	10	10	
	External regenerative resistor (Standard accessory) (Note 5, 6)	—	—	—	—	—	—	—	—	—	—	500 (800)	850 (1300)	850 (1300)	—	—	—	
Control system		Sine-wave PWM control/current control system																
Dynamic brake		Built-in (Note 8)											External option			Built-in (Note 8)		
Safety features		Overcurrent shutdown, regeneration overvoltage shutdown, overload shutdown (electronic thermal), servo motor overheat protection, encoder fault protection, regeneration fault protection, undervoltage/sudden power outage protection, overspeed protection, excess error protection																
Structure		Self-cooling open (IP00)						Fan cooling open (IP00)						Self-cooling open (IP00)				
Environment	Ambient temperature (Note 9)	0 to 55°C (32 to 131°F) (non freezing), storage: -20 to 65°C (-4 to 149°F) (non freezing)																
	Ambient humidity	90% RH maximum (non condensing), storage: 90% RH maximum (non condensing)																
	Atmosphere	Indoors (no direct sunlight); no corrosive gas, inflammable gas, oil mist or dust																
	Elevation	1000m or less above sea level																
	Vibration	5.9m/s <sup>2</sup> maximum																
Mass (kg [lb])		0.8 (1.8)	0.8 (1.8)	1.0 (2.2)	1.0 (2.2)	1.4 (3.1)	1.4 (3.1)	2.3 (5.1)	2.3 (5.1)	4.6 (10)	6.2 (14)	18 (40)	18 (40)	19 (42)	0.8 (1.8)	0.8 (1.8)	1.0 (2.2)	

- Notes: 1. Rated output and rated speed of the servo motor used in combination with the servo amplifier are as indicated when using the power supply voltage and frequency listed. The torque drops when the power supply voltage is less than specified.  
2. For torque characteristics when combined with a servo motor, refer to the section "Servo motor torque characteristics" in this catalog.  
3. Optimal regenerative resistor varies for each system. Select the most suitable regenerative resistor by using the capacity selection software.  
4. Refer to the section "Options ●Optional regeneration unit" in this catalog for the tolerable regenerative power (W).  
5. The servo amplifier (MR-J3-□KT-PX) without an enclosed regenerative resistor is also available.  
6. The value applies when the external regenerative resistors, GRZG400-□Ω, (standard accessory) are used with cooling fans (2 units of 92 X 92mm, minimum air flow: 1.0m<sup>3</sup>/min). Note that change in the parameter No. PA02 is required.  
7. 150mA is the value when all of the input/output points are used. The current capacity can be stepped down according to the number of input/output points in use. Refer to "MR-J3-□T SERVO AMPLIFIER INSTRUCTION MANUAL" for details.  
8. Special specification models without a dynamic brake, MR-J3-□T-ED and MR-J3-□T1-ED, are also available.  
9. The MR-J3-350T or smaller servo amplifier can be installed closely. In this case, keep the ambient temperature within 0 to 45°C (32 to 113°F), or use the servo amplifier with 75% or less of the effective load rate.  
10. The special specification model, MR-J3-□T-U004, is also available for 1-phase 200 to 240VAC.

# Amplifier Specifications



## MR-J3-T servo amplifier specifications: 400VAC

Servo amplifier model MR-J3-		60T4	100T4	200T4	350T4	500T4	700T4	11KT4	15KT4	22KT4	
Main circuit power supply	Voltage/frequency (Note 1, 2)	3-phase 380 to 480VAC 50/60Hz									
	Permissible voltage fluctuation	3-phase 323 to 528VAC									
	Permissible frequency fluctuation	±5% maximum									
Control circuit power supply	Voltage/frequency	1-phase 380 to 480VAC 50/60Hz									
	Permissible voltage fluctuation	1-phase 323 to 528VAC									
	Permissible frequency fluctuation	±5% maximum									
	Power consumption (W)	30			45						
Interface power supply		24VDC ±10% (required current capacity: 150mA (Note 7))									
Regenerative resistor/ tolerable regenerative power (W) (Note 3, 4)	Built-in regenerative resistor	15	15	100	100	130 (Note 9)	170 (Note 9)	—	—	—	
	External regenerative resistor (Standard accessory) (Note 5, 6)	—	—	—	—	—	—	500 (800)	850 (1300)	850 (1300)	
Control system		Sine-wave PWM control/current control system									
Dynamic brake		Built-in (Note 8, 10)						External option			
Safety features		Overcurrent shutdown, regeneration overvoltage shutdown, overload shutdown (electronic thermal), servo motor overheat protection, encoder fault protection, regeneration fault protection, undervoltage/sudden power outage protection, overspeed protection, excess error protection									
Structure		Self-cooling open (IP00)			Fan cooling open (IP00)						
Environment	Ambient temperature	0 to 55°C (32 to 131°F) (non freezing), storage: -20 to 65°C (-4 to 149°F) (non freezing)									
	Ambient humidity	90% RH maximum (non condensing), storage: 90% RH maximum (non condensing)									
	Atmosphere	Indoors (no direct sunlight); no corrosive gas, inflammable gas, oil mist or dust									
	Elevation	1000m or less above sea level									
	Vibration	5.9m/s <sup>2</sup> maximum									
Mass (kg [lb])		1.7 (3.7)	1.7 (3.7)	2.1 (4.6)	4.6 (10)	4.6 (10)	6.2 (14)	18 (40)	18 (40)	19 (42)	

- Notes: 1. Rated output and rated speed of the servo motor used in combination with the servo amplifier are as indicated when using the power supply voltage and frequency listed. The torque drops when the power supply voltage is less than specified.
2. For torque characteristics when combined with a servo motor, refer to the section "Servo motor torque characteristics" in this catalog.
3. Optimal regenerative resistor varies for each system. Select the most suitable regenerative resistor by using the capacity selection software.
4. Refer to the section "Options ●Optional regeneration unit" in this catalog for the tolerable regenerative power (W).
5. The servo amplifier (MR-J3-□KT4-PX) without an enclosed regenerative resistor is also available.
6. The value applies when the external regenerative resistors, GRZG400-□Ω, (standard accessory) are used with cooling fans (2 units of 92 × 92mm, minimum air flow: 1.0m<sup>3</sup>/min). Note that change in the parameter No. PA02 is required.
7. 150mA is the value when all of the input/output points are used. The current capacity can be stepped down according to the number of input/output points in use. Refer to "MR-J3-□T SERVO AMPLIFIER INSTRUCTION MANUAL" for details.
8. Special specification models without a dynamic brake, MR-J3-□T4-ED are also available.
9. The amplifier built-in resistor is compatible with the maximum torque deceleration when the motor is used within the rated speed and the recommended load/motor inertia moment ratio. Contact Mitsubishi if the operating motor speed and the load/motor inertia moment ratio exceed the rated speed and the recommended ratio.
10. For the servo amplifier 5kW or 7kW, the load/motor of inertia moment ratio must be 5 times or less when the amplifier built-in dynamic brake is used, and the motor speed exceeds 2000r/min.

# Amplifier Specifications



## MR-J3-T command and operation mode

Item		Description		
Command interface		CC-Link communication (Ver.1.10), DIO command (extension IO unit MR-J3-D01 is required), or RS-422 communication		
Operation system	Point table	Remote register	Possible with CC-Link communication when 2 stations occupied. Position command input: position command data is set with the remote register. Feed length input setting range: $\pm 1\mu\text{m}$ to $\pm 999.999\text{mm}$ . Speed command input: speed command data (rotating speed) is set with the remote register.	
		Point table No. input	Possible with CC-Link communication, DIO command or RS-422 communication CC-Link communication (when 1 station occupied): 31 points CC-Link communication (when 2 stations occupied): 255 points DIO command: 255 points (extension IO unit MR-J3-D01 is required.) RS-422 communication: 255 points Position command input: selects from the point table. 1-point feed length setting range: $\pm 1\mu\text{m}$ to $\pm 999.999\text{mm}$ . Speed command input: selects speed and acceleration/deceleration time constant from the point table.	
	Automatic operation mode	Point table	Point table No. input or point table data input system. Each positioning operation based on position and speed data. Speed changing operation (2 to 255 speeds). Automatic continuous positioning operation (2 to 255 points) Roll feed display is selectable. Clearing droop pulses with the clear (CR) signal is settable.	
	Manual operation mode	JOG operation	Inches upon contact input, CC-Link communication or RS-422 communication based on speed data set by a parameter.	
		Manual pulse generator	Manual feed with the manual pulse generator. Command pulse multiplication: X1, X10, X100 is selectable with parameter.	
	Index system	Command method	Station position command input	Possible with CC-Link communication, DIO command or RS-422 communication CC-Link communication (when 1 station occupied): 31 stations CC-Link communication (when 2 stations occupied): 255 stations DIO command: 255 stations (extension IO unit MR-J3-D01 is required.) RS-422 communication: 255 stations
			Speed command input	Remote register
		Speed No. input		Selects speed and acceleration/deceleration time constant from the point table.
		Automatic operation mode	Rotating direction specified	Positions to the specified station. Rotating direction is settable.
			Shortest rotating direction	Positions to the specified station. Shorter rotating direction from the current point is selected.
Manual operation mode		Index JOG operation	Rotates in a direction specified by rotating direction evaluation when the start signal (ST1) turns ON. Positions to a nearest station where deceleration to a stop is possible when the start signal (ST1) turns OFF.	
	JOG operation	Inches upon contact input, CC-Link communication or RS-422 communication based on speed data set by a parameter.		
Home position return mode	Dog system		Returns to home position upon Z-phase pulse count after passing through near-point dog. Direction for return to home position selectable. Home position shift amount and home position address settable. Automatic retreat on dog back to home position and automatic stroke retreat function.	
	Count system		Returns to home position upon encoder pulse count after touching near-point dog. Direction for return to home position selectable. Home position shift amount and home position address settable. Automatic retreat on dog back to home position and automatic stroke retreat function.	
	Data set system		Returns to home position without dog. Sets any position as home position using manual operation, etc. Home position address settable.	
	Stopper system		Returns to home position upon hitting end of stroke. Direction for return to home position selectable. Home position address settable.	
	Ignore home (Servo-on position as home position)		Uses position where the servo on signal (SON) turns ON as home position. Home position address settable.	
	Dog system rear end reference		Returns to home position with respect to the rear end of a near-point dog. Direction for return to home position selectable. Home position shift amount and home position address settable. Automatic retreat on dog back to home position and automatic stroke retreat function.	
	Count system front end reference		Returns to home position with respect to the front end of a near-point dog. Direction for return to home position selectable. Home position shift amount and home position address settable. Automatic retreat on dog back to home position and automatic stroke retreat function.	
	Dog cradle system		Returns to home position upon the first Z-phase pulse with respect to the front end of a near-point dog. Direction for return to home position selectable. Home position shift amount and home position address settable. Automatic retreat on dog back to home position and automatic stroke retreat function.	
	Dog system adjacent Z-phase reference		Returns to home position upon the Z-phase pulse right before a near-point dog with respect to the front end of a near-point dog. Direction for return to home position selectable. Home position shift amount and home position address settable. Automatic retreat on dog back to home position and automatic stroke retreat function.	
	Dog system front end reference		Returns to home position to the front end of a point dog with respect to the front end of a near-point dog. Direction for return to home position selectable. Home position shift amount and home position address settable. Automatic retreat on dog back to home position and automatic stroke retreat function.	
	Dog less Z-phase reference		Returns to home position to the first Z-phase pulse with respect to the first Z-phase pulse. Direction for return to home position selectable. Home position shift amount and home position address settable	
	Dog system torque limit		Returns to home position upon Z-phase pulse count after passing through near-point dog. Direction for return to home position selectable. Home position shift amount and home position address settable. Automatic retreat on dog back to home position and automatic stroke retreat function. Torque limit settable.	
	Data set system torque limit		Returns to home position without dog. Sets any position as home position by manual movement. Home position address and torque limit settable.	
Automatic positioning to home position function		High-speed automatic positioning to a defined home position		

# Extension IO Unit

## MR-J3-D01 specifications

Item		Description
Model		MR-J3-D01
Power supply for interface		24VDC $\pm 10\%$ (required current capacity: 800mA (Note 1, 2))
Digital input		30 points, photocoupler insulation, sink/source compatible
Digital output		16 points, photocoupler insulation, sink/source compatible
Analog input		2ch, 0 to $\pm 10$ VDC (input impedance: 10 to 12k $\Omega$ )
Analog output		2ch, 0 to $\pm 12$ VDC
Power supply for analog input signal		P15R: DC+15V, permissible current: 30mA (Note 5) N12R: DC-12V, permissible current: 30mA
Structure		Self-cooling open (IP00)
Environment	Ambient temperature	0 to 55°C (32 to 131°F) (non freezing), storage: -20 to 65°C (-4 to 149°F) (non freezing)
	Ambient humidity	90% RH maximum (non condensing), storage: 90% RH maximum (non condensing)
	Atmosphere	Indoors (no direct sunlight); no corrosive gas, inflammable gas, oil mist or dust
	Elevation	1000m or less above sea level
	Vibration	5.9m/s <sup>2</sup> maximum
Mass (g [lb])		140 (0.31)

### <Functions connecting to MR-J3-□T□>

Function		Description
Digital input		Point table No. selection 1 to 8 (DI0 to DI7), Servo-on (SON), Reset (RES), External torque limit selection (TL), Internal torque limit selection (TL1), Manual pulse generator multiplication 1, 2 (TP0, TP1), Override selection (OVR), Automatic/manual selection (MD0), Temporary stop/restart (TSTP), Proportional control (PC), Forward rotation start (ST1), Reverse rotation start (ST2), Position data input 1 to 12 (POS00 to POS03, POS10 to POS13, POS20 to POS23), Position data input symbol+ (POSP), Clear (CR), Position data input symbol- (POSN), Strobe (STRB), Speed selection 1 to 3 (SP0 to SP2), Gain changing (CDP) (Note3)
Digital output		Alarm code (ACD0 to ACD3), M code (MCD00 to MCD03, MCD10 to MCD13), Temporary stop (PUS), Positioning complete (MEND), Phase match (CPO), In-position (INP), Position data request 1, 2 (PRQ1, PRQ2), Zero speed (ZSP), Torque limit in effect (TLC), Warning (WNG), Electromagnetic brake interlock (MBR), Dynamic brake interlock (DB), Battery warning (BWNG), Positioning range output (POT), Variable gain selection (CDPS), Command speed reached (SA), Point table No. output 1 to 8 (PT0 to PT7) (Note3)
Analog input		Override (VC) (-10 to +10VDC/0 to 200%) Analog torque limit (TLA) (0 to $\pm 10$ VDC/maximum torque)
Analog output		Analog monitor output (MO1, MO2) (Note 4)

### <Functions connecting to MR-J3-□A□-RJ040>

Function		Description
Position control mode	Electric gear numerator digital input	The electric gear numerator can be set arbitrarily in 5-digit BCD or 16-bit binary.
	High resolution analog torque limit	The torque limit can be set according to the rotating direction. (TLAP: 0 to +10VDC/maximum torque) (TLAN: 0 to -10VDC/maximum torque)
Speed control mode	Digital speed command input	The speed command can be set arbitrarily in 5-digit BCD or 12-bit (16-bit) binary.
	High resolution analog torque limit	The torque limit can be set according to the rotating direction. (TLAP: 0 to +10VDC/maximum torque) (TLAN: 0 to -10VDC/maximum torque)
Torque control mode	Digital speed limit input	The speed limit can be set arbitrarily in 5-digit BCD or 12-bit (16-bit) binary.
	High resolution torque command input	External analog torque command (OTC) (0 to $\pm 8$ VDC/maximum torque)

- Notes: 1. 800mA is the value when all of the input/output points are used. The current capacity can be stepped down according to the number of input/output points in use. Refer to "MR-J3-□T MR-J3-D01 SERVO AMPLIFIER INSTRUCTION MANUAL" for details.
2. A 24VDC power supply for input/output signals can be shared by the servo amplifier and MR-J3-D01. In this case, secure the power supply capacity corresponding to the points of the input/output signals to be used.
3. The signal assignment can be changed by setting the parameters. Refer to "MR-J3-□T MR-J3-D01 SERVO AMPLIFIER INSTRUCTION MANUAL" for details.
4. Analog monitor output can be selected by setting the parameter. Refer to "MR-J3-□T MR-J3-D01 SERVO AMPLIFIER INSTRUCTION MANUAL" for details.
5. P15R can be used as a power supply for TLA and VC. N12R can be used as a power supply for VC. Note that the power voltage varies between -12 to -15V.



## Extension IO unit dimensions

(Unit: mm)

● MR-J3-D01

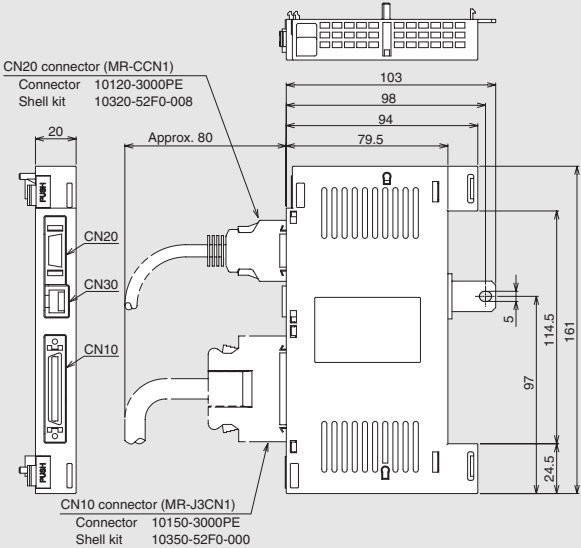

● Dimensions when MR-J3-D01 is installed

- 100V/200V 0.1kW to 3.5kW
- 400V 0.6kW to 2kW

- 200V 5kW, 7kW
- 400V 3.5kW to 7kW

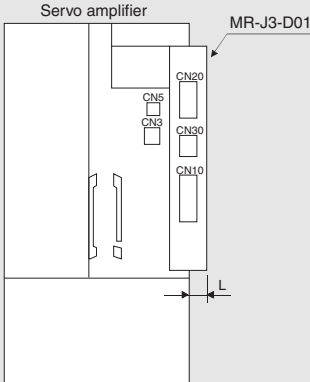
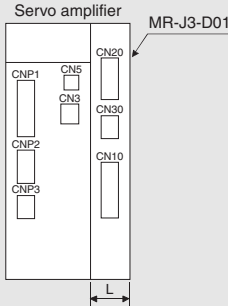

Servo amplifier model	Variable dimension
	L
MR-J3-10T(1) to 100T(4) MR-J3-10A(1)-RJ040 to 100A-RJ040	20
MR-J3-200T(4), 350T MR-J3-200A-RJ040, 350A-RJ040	15
MR-J3-350T4, 500T(4), 700T(4) MR-J3-500A-RJ040, 700A-RJ040	10

Note: For servo amplifier 200V/400V 11kW to 22kW, MR-J3-D01 will be built into the servo amplifier.

# Standard Wiring Diagram

## MR-J3-□T□

### ● Connection example

#### Main circuit/control circuit power supply connection

The connection differs according to the power voltage.  
→Refer to the main circuit/control circuit power supply connection examples (1) to (6).

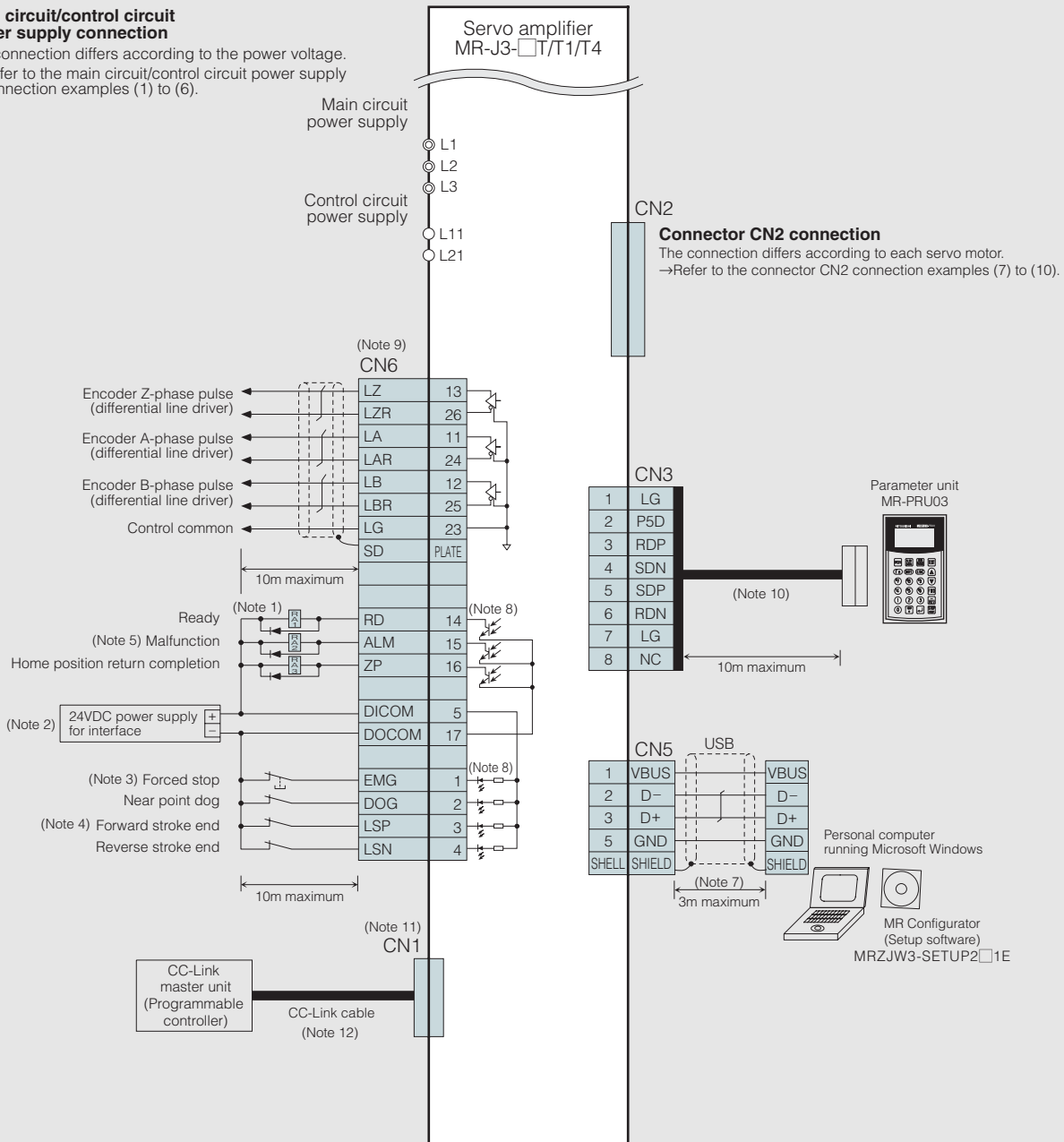

#### Notes:

- Do not reverse the diode's direction. Connecting it backwards could cause the servo amplifier to malfunction such that the signals are not output, and the forced stop and other safety circuits are inoperable.
- Use the power supply 24VDC±10% (required current capacity: 150mA). 150mA is the value when all of the input/output points are used. Note that the current capacity can be stepped down according to the number of input/output points in use. Refer to "MR-J3-□T SERVO AMPLIFIER INSTRUCTION MANUAL" for details.
- Turn on the forced stop (EMG) signal (normally closed contact) before starting the operation, or cancel the forced stop signal with the parameter No. PD01.
- Close the forward/reverse stroke end (LSP, LSN) signals (normally closed contact) or turn on the forward/reverse stroke end signals with the parameter No. PD01 before starting the operation.
- The malfunction (ALM) signal is conducted to DOCOM in normal alarm-free condition.
- Connect the shield wire securely to the plate inside the connector (ground plate).
- The cable length up to 3m is possible in a low noise environment.
- This is for sink wiring. Source wiring is also possible. Refer to "MR-J3-□T SERVO AMPLIFIER INSTRUCTION MANUAL" for details.
- Use the optional connector, MR-J2CMP2 for the CN6 connector.
- Use a commercial LAN cable (EIA568 compliant). A personal computer can be connected using a RS-422/RS-232 conversion cable. Note that USB interface (CN5 connector) and RS-422 interface (CN3 connector) are mutually exclusive. They cannot be used at the same time. Refer to the section "Ordering Information for Customers" in this catalog for the RS-422/RS-232 conversion cable.
- The CN1 connector is used only when operated with CC-Link communication. Manufacture a CC-Link cable using the CN1 connector supplied with the servo amplifier.
- For the CC-Link cable, refer to the section "Ordering Information for Customers" in this catalog for details.

## MR-J3-D01 (Option)

### ● Connection example

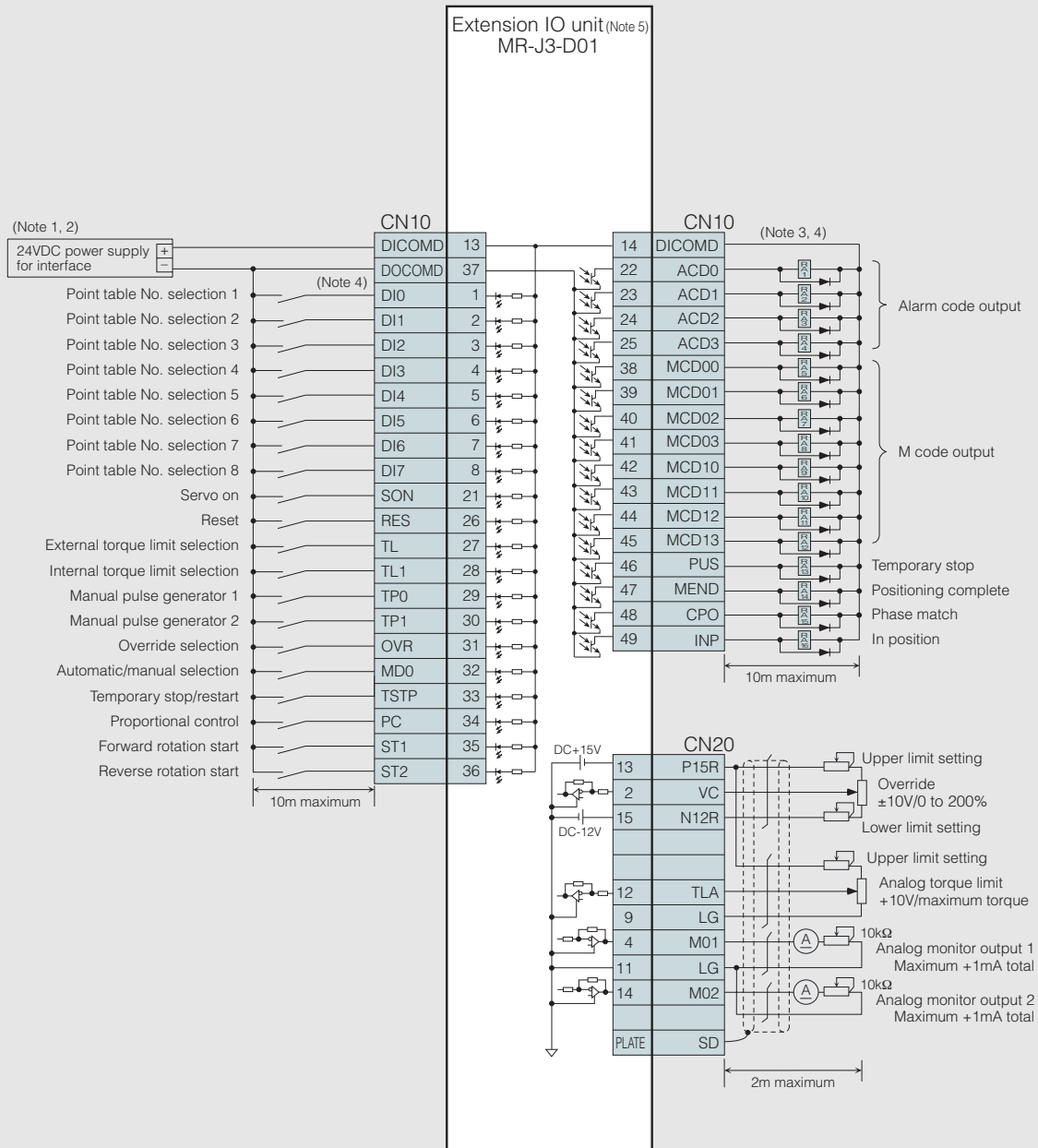

#### Notes:

1. Use the power supply 24VDC±10% (required current capacity: 800mA). 800mA is the value when all of the input/output points are used. Note that the current capacity can be stepped down according to the number of input/output points in use. Refer to "MR-J3-□T MR-J3-D01 SERVO AMPLIFIER INSTRUCTION MANUAL" for details.
2. A 24VDC power supply for input/output signals can be shared by the servo amplifier and MR-J3-D01. In this case, secure the power supply capacity corresponding to the points of the input/output signals to be used.
3. Do not reverse the diode's direction. Connecting it backwards could cause the servo amplifier and/or MR-J3-D01 to malfunction such that the signals are not output, and the forced stop and other safety circuits are inoperable.
4. This is for sink wiring. Source wiring is also possible. Refer to "MR-J3-□T MR-J3-D01 SERVO AMPLIFIER INSTRUCTION MANUAL" for details.
5. MR-J3-D01 connects directly to the CN7 connector of the servo amplifier, MR-J3-□T□ or MR-J3-□A□-RJ040.

# Amplifier Dimensions

## MR-J3-□T□

(Unit: mm)

### ● MR-J3-10T, 20T, 10T1, 20T1 (Note)

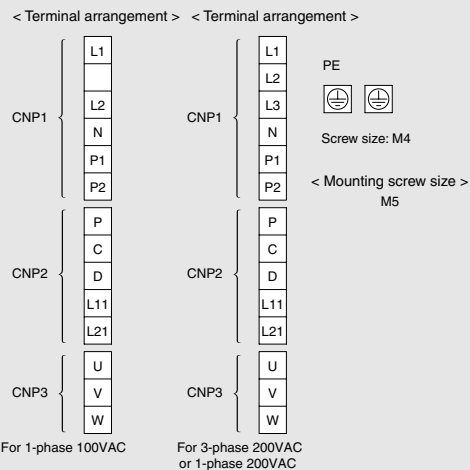
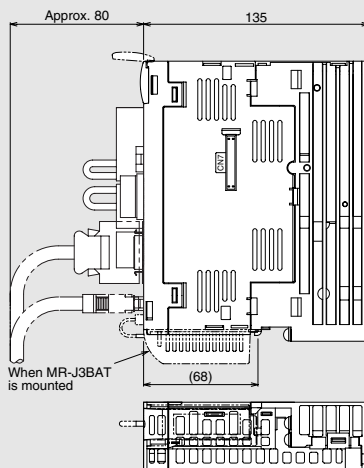
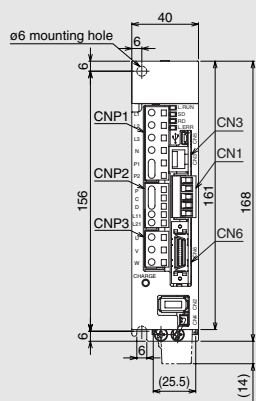

### ● MR-J3-40T, 60T, 40T1 (Note)

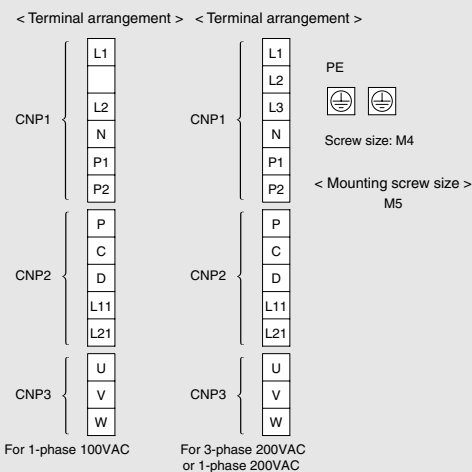
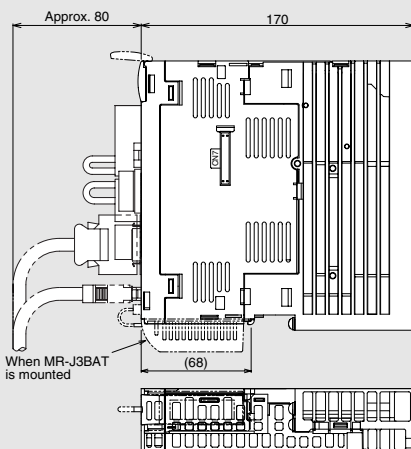
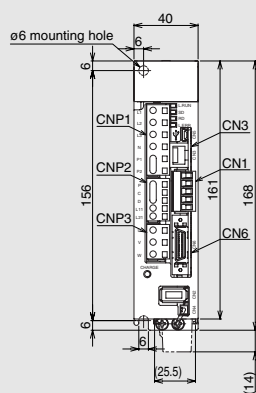

### ● MR-J3-70T, 100T (Note)

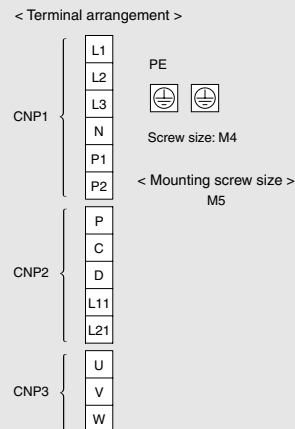
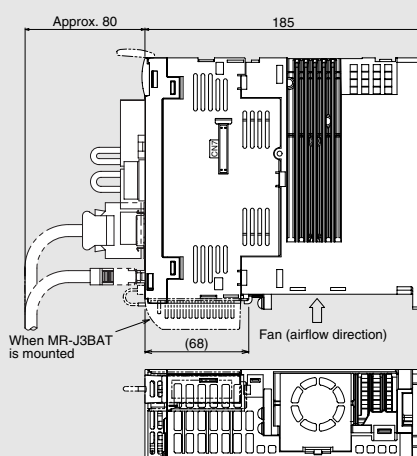
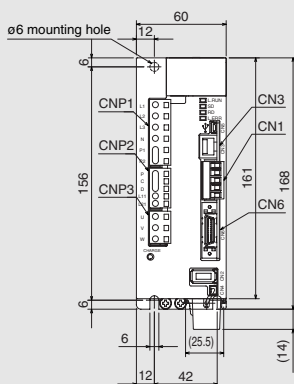

# Amplifier Dimensions

(Unit: mm)

## ● MR-J3-60T4, 100T4 (Note)

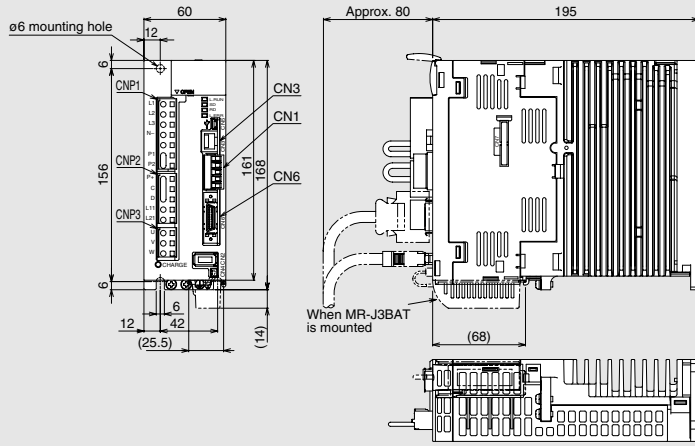

< Terminal arrangement >

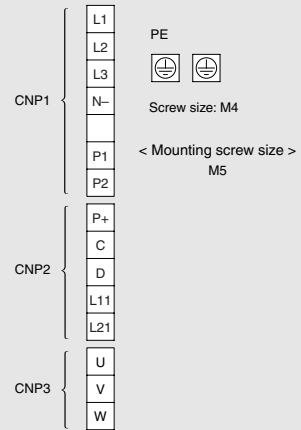

## ● MR-J3-200T, 350T (Note)

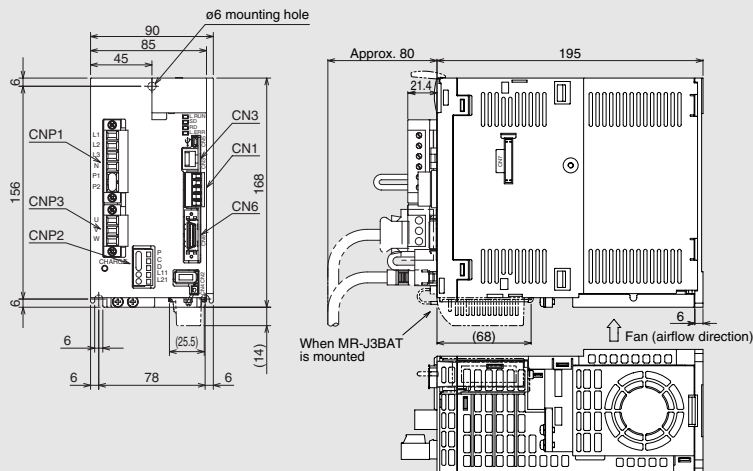

< Terminal arrangement >

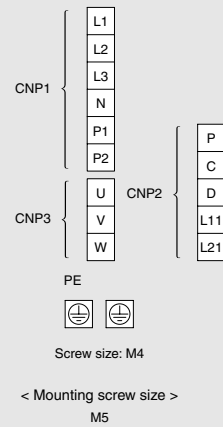

## ● MR-J3-200T4 (Note)

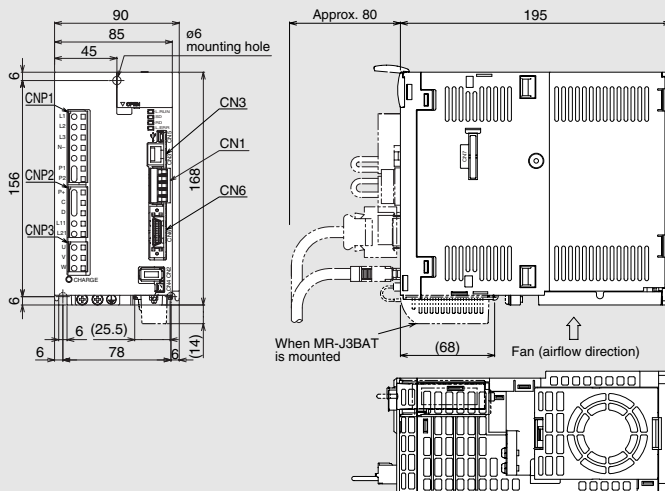

< Terminal arrangement >

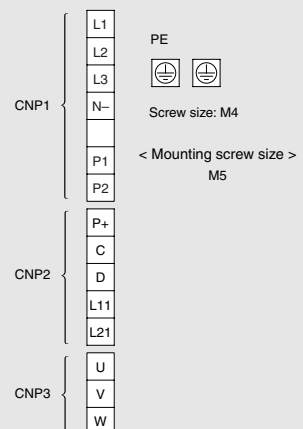

Note: The connectors CNP1, CNP2 and CNP3 (insertion type) are supplied with the servo amplifier.

# Amplifier Dimensions

(Unit: mm)

## ● MR-J3-500T, 350T4, 500T4

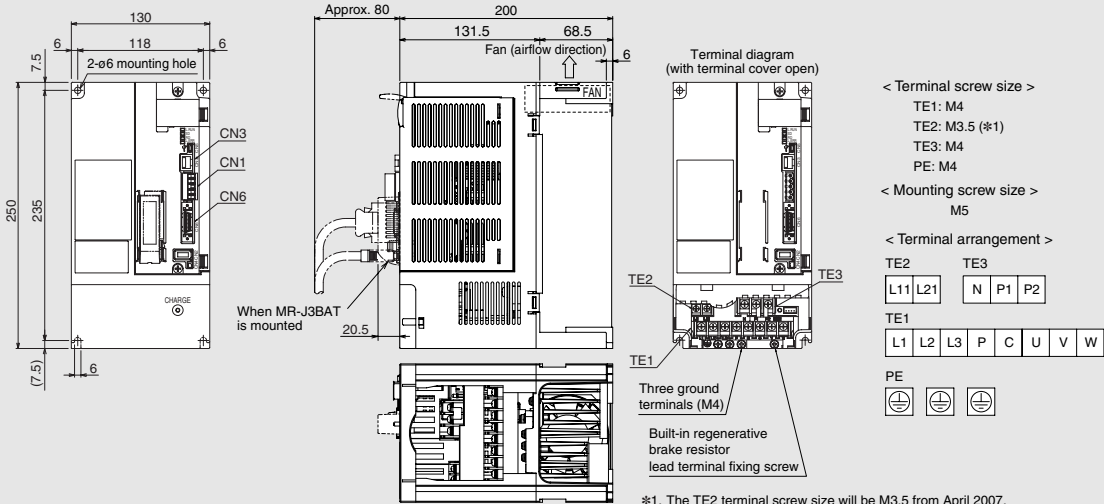

\*1. The TE2 terminal screw size will be M3.5 from April 2007. For the servo amplifiers manufactured on or before March 2007, the terminal screw size is M3.

## ● MR-J3-700T, 700T4

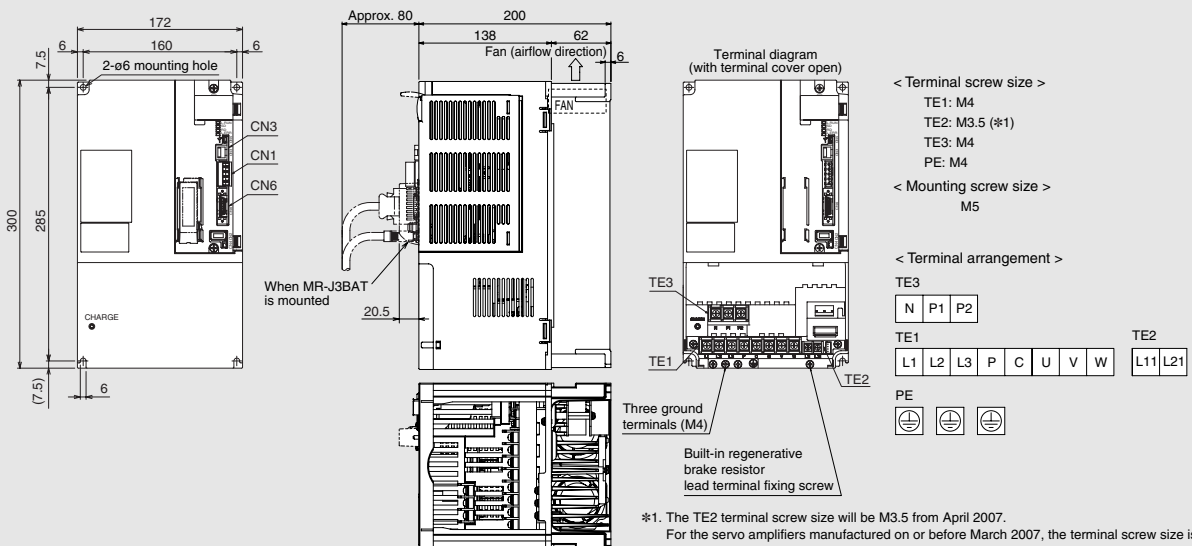

\*1. The TE2 terminal screw size will be M3.5 from April 2007. For the servo amplifiers manufactured on or before March 2007, the terminal screw size is M3.

## ● MR-J3-11KT to 22KT, 11KT4 to 22KT4

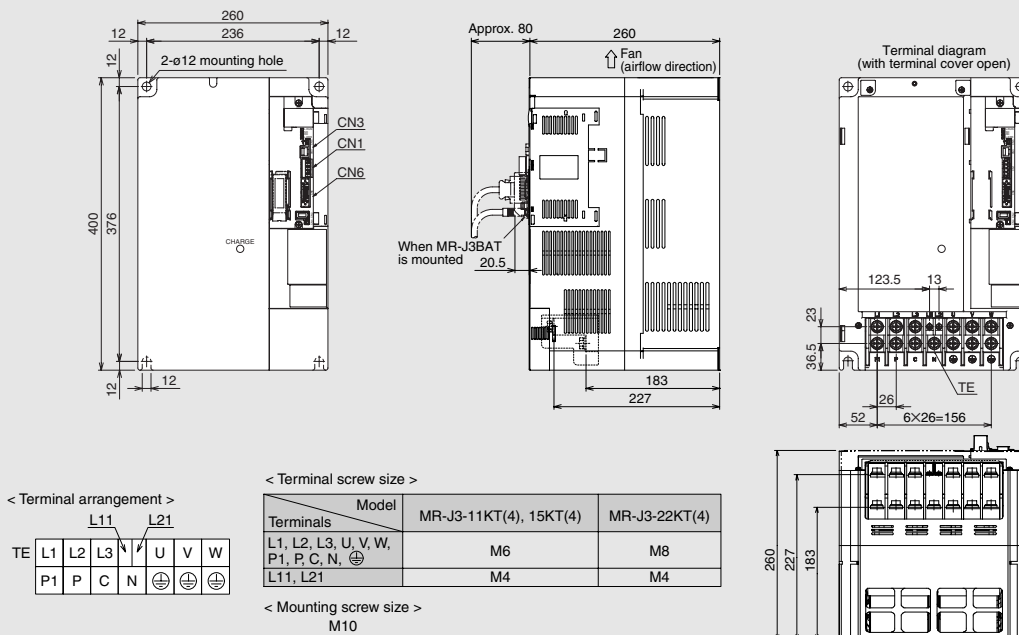

# Options

## ● Dynamic brake

When using an 11kW or larger servo amplifier, use the dynamic brake if the servo motor must be suddenly stopped during a power failure or when the protection circuit functions.

Model	Servo amplifier	Fig.	Model	Drive unit	Fig.
DBU-11K	MR-J3-11KA/B/T	A	DBU-37K	MR-J3-DU30KA/B	C
DBU-15K	MR-J3-15KA/B/T			MR-J3-DU37KA/B	
DBU-22K	MR-J3-22KA/B/T			MR-J3-DU30KA4/B4	
DBU-11K-4	MR-J3-11KA4/B4/T4	B	MR-J3-DU37KA4/B4		
DBU-22K-4	MR-J3-15KA4/B4/T4		MR-J3-DU45KA4/B4		
	MR-J3-22KA4/B4/T4		MR-J3-DU55KA4/B4		

External dimensions		Connections																																																											
(Unit: mm)																																																													
<p><b>A</b></p> <table border="1"> <thead> <tr> <th>Model</th> <th>A</th> <th>B</th> <th>C</th> <th>D</th> <th>E</th> <th>F</th> <th>G</th> <th>Mass kg (lb)</th> <th>Electrical wire size (mm<sup>2</sup>)</th> </tr> </thead> <tbody> <tr> <td>DBU-11K</td> <td>200</td> <td>190</td> <td>140</td> <td>20</td> <td>5</td> <td>170</td> <td>163.5</td> <td>2 (4.4)</td> <td>5.5 (AWG10)</td> </tr> <tr> <td>DBU-15K</td> <td>250</td> <td>238</td> <td>150</td> <td>25</td> <td>6</td> <td>235</td> <td>228</td> <td>6 (13)</td> <td>5.5 (AWG10)</td> </tr> </tbody> </table>	Model	A	B	C	D	E	F	G	Mass kg (lb)	Electrical wire size (mm <sup>2</sup> )	DBU-11K	200	190	140	20	5	170	163.5	2 (4.4)	5.5 (AWG10)	DBU-15K	250	238	150	25	6	235	228	6 (13)	5.5 (AWG10)	<p><b>B</b></p> <table border="1"> <thead> <tr> <th rowspan="2">Model</th> <th rowspan="2">Mass kg (lb)</th> <th colspan="2">Electrical wire size (mm<sup>2</sup>)</th> </tr> <tr> <th>U, V, W</th> <th>Other than U, V, W</th> </tr> </thead> <tbody> <tr> <td>DBU-11K-4</td> <td>6.7</td> <td>5.5</td> <td>2</td> </tr> <tr> <td>DBU-22K-4</td> <td>(15)</td> <td>(AWG10)</td> <td>(AWG14)</td> </tr> </tbody> </table>	Model	Mass kg (lb)	Electrical wire size (mm <sup>2</sup> )		U, V, W	Other than U, V, W	DBU-11K-4	6.7	5.5	2	DBU-22K-4	(15)	(AWG10)	(AWG14)	<p><b>C</b></p> <table border="1"> <thead> <tr> <th rowspan="2">Model</th> <th rowspan="2">Mass kg (lb)</th> <th colspan="2">Electrical wire size (mm<sup>2</sup>)</th> </tr> <tr> <th>U, V, W</th> <th>Other than U, V, W</th> </tr> </thead> <tbody> <tr> <td>DBU-37K</td> <td>8 (18)</td> <td>14</td> <td>2</td> </tr> <tr> <td>DBU-55K-4</td> <td>11 (24)</td> <td>(AWG6)</td> <td>(AWG14)</td> </tr> </tbody> </table>	Model	Mass kg (lb)	Electrical wire size (mm <sup>2</sup> )		U, V, W	Other than U, V, W	DBU-37K	8 (18)	14	2	DBU-55K-4	11 (24)	(AWG6)	(AWG14)	<p><b>Connections</b></p>
Model	A	B	C	D	E	F	G	Mass kg (lb)	Electrical wire size (mm <sup>2</sup> )																																																				
DBU-11K	200	190	140	20	5	170	163.5	2 (4.4)	5.5 (AWG10)																																																				
DBU-15K	250	238	150	25	6	235	228	6 (13)	5.5 (AWG10)																																																				
Model	Mass kg (lb)	Electrical wire size (mm <sup>2</sup> )																																																											
		U, V, W	Other than U, V, W																																																										
DBU-11K-4	6.7	5.5	2																																																										
DBU-22K-4	(15)	(AWG10)	(AWG14)																																																										
Model	Mass kg (lb)	Electrical wire size (mm <sup>2</sup> )																																																											
		U, V, W	Other than U, V, W																																																										
DBU-37K	8 (18)	14	2																																																										
DBU-55K-4	11 (24)	(AWG6)	(AWG14)																																																										

- Notes: 1. The connection diagrams, Fig. A and B, are for MR-J3-□B(4) and Fig. C for MR-J3-DU□B(4). For connection diagram for MR-J3-□A(4) or MR-J3-DU□A(4), refer to "MR-J3-□A SERVO AMPLIFIER INSTRUCTION MANUAL".
2. Validate the dynamic brake interlock (DB) signal with the parameter No. PD07 to PD09 for MR-J3-□B(4) or MR-J3-DU□B(4).
3. The terminals 13 and 14 are normally opened outputs. If the dynamic brake is welded, the terminals 13 and 14 will be opened. So, create the external sequence that the servo on signal does not turn on when the terminals 13 and 14 are opened.
4. This is for 400V. The 200V does not require a step-down transformer.
5. Create a circuit that validates the forced stop (EM1) signals of the drive unit and the converter unit at the same time.
6. When using DBU-11K-4 or DBU-22K-4, the power supply must be between 1-phase 380VAC to 463VAC 50/60Hz. Refer to "MR-J3 SERVO AMPLIFIER MANUAL" for details.

# MR-J3 Basic Configuration

## MR-J3-Basic configuration

Necessary optional cables and connectors vary depending on the servo amplifier type and servo motor series. Follow the flow below to make sure the options required.

### ● Selecting options for servo amplifiers

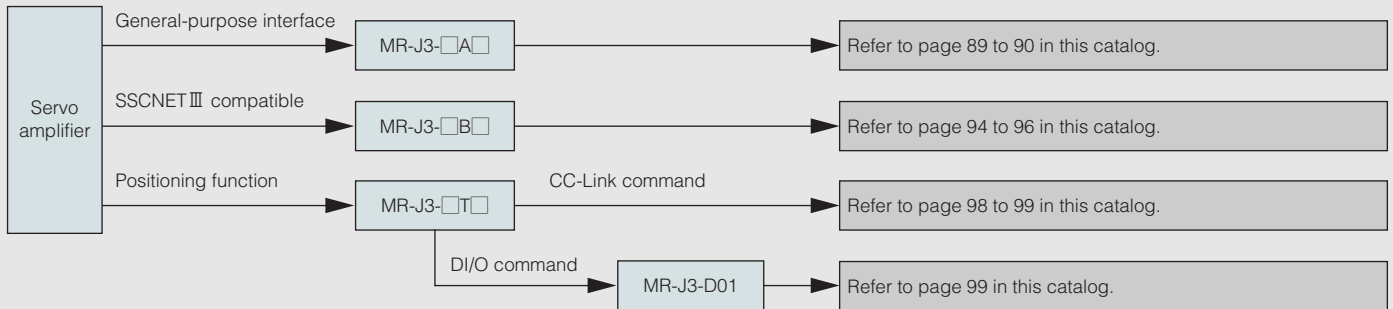

### ● Selecting cables for servo motor

Use the cables below for connecting the servo motor with the servo amplifier. Refer to the cable list in the following page for the corresponding cables.

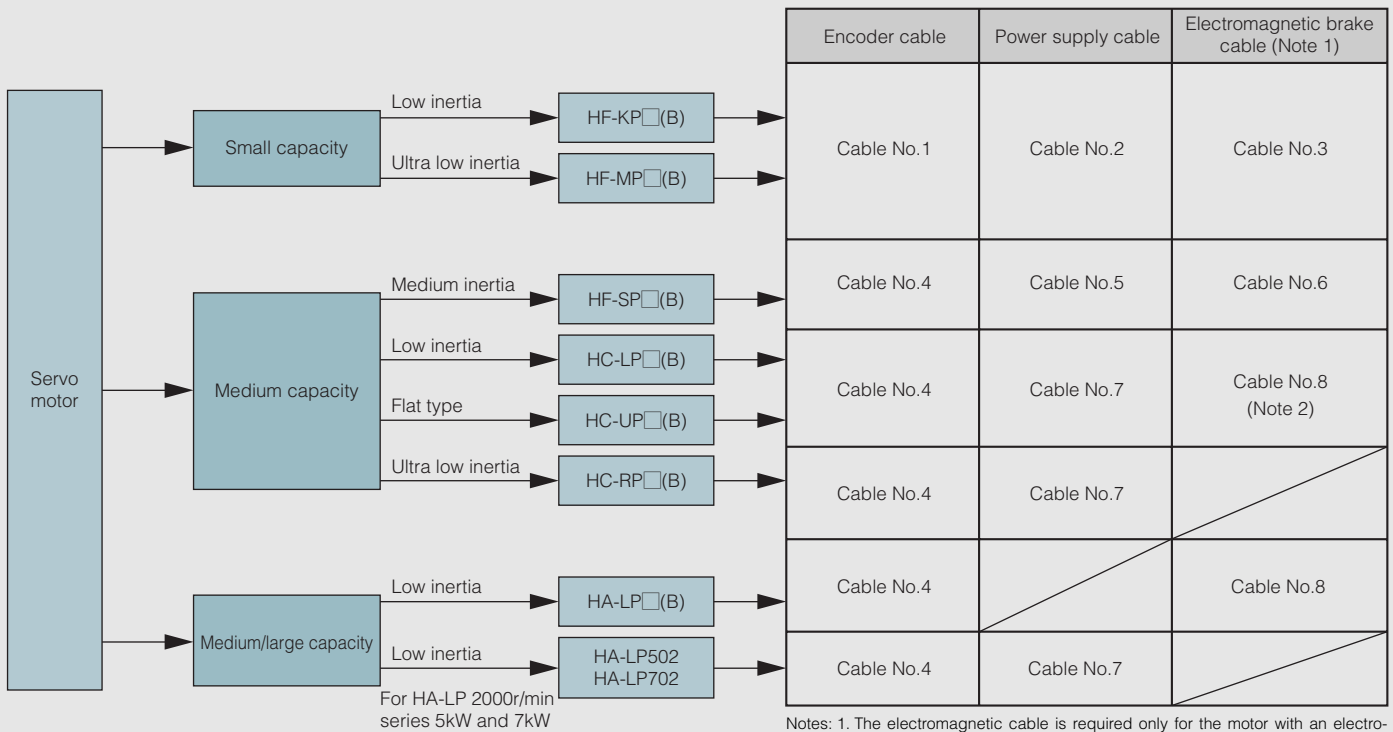

Notes: 1. The electromagnetic cable is required only for the motor with an electromagnetic brake.  
 2. The electromagnetic cable is not required for 1.5kW or smaller servo motors of HC-LP series and of HC-UP series as the power supply connector has electromagnetic brake terminals.



## ● Cables for servo motors

No.	Item				Model		
1	Encoder cable: Select one from the following (1) to (8).						
	10m or shorter (Direct connection type)	IP65	Lead out in direction of motor shaft	Long bending life	(1)	MR-J3ENCBL□M-A1-H	Refer to item ① on page 91 of this catalog.
				Standard	(2)	MR-J3ENCBL□M-A1-L	
			Lead out in opposite direction of motor shaft	Long bending life	(3)	MR-J3ENCBL□M-A2-H	Refer to item ② on page 91 of this catalog.
				Standard	(4)	MR-J3ENCBL□M-A2-L	
	Exceeding 10m (Relay type)	IP20	Lead out in direction of motor shaft	Long bending life	(5)	Two types of cables are required. • MR-J3JCBL03M-A1-L • MR-EKCBL□M-H	Refer to item ③ and ⑤ on page 91 of this catalog.
				Standard	(6)	Two types of cables are required. • MR-J3JCBL03M-A1-L • MR-EKCBL□M-L	
			Lead out in opposite direction of motor shaft	Long bending life	(7)	Two types of cables are required. • MR-J3JCBL03M-A2-L • MR-EKCBL□M-H	Refer to item ④ and ⑤ on page 91 of this catalog.
Standard				(8)	Two types of cables are required. • MR-J3JCBL03M-A2-L • MR-EKCBL□M-L		
2	Motor power supply cable: Select one from the following (1) to (6).						
	10m or shorter (Direct connection type)	IP65	Lead out in direction of motor shaft	Long bending life	(1)	MR-PWS1CBL□M-A1-H	Refer to item ⑩ on page 91 of this catalog.
				Standard	(2)	MR-PWS1CBL□M-A1-L	
			Lead out in opposite direction of motor shaft	Long bending life	(3)	MR-PWS1CBL□M-A2-H	Refer to item ⑪ on page 91 of this catalog.
				Standard	(4)	MR-PWS1CBL□M-A2-L	
	Exceeding 10m (Relay type)	IP55	Lead out in direction of motor shaft	Standard	(5)	Use a user-manufactured cable connected to MR-PWS2CBL03M-A1-L (optional cable).	Refer to item ⑫ on page 91 of this catalog.
Lead out in opposite direction of motor shaft			Standard	(6)	Use a user-manufactured cable connected to MR-PWS2CBL03M-A2-L (optional cable).	Refer to item ⑬ on page 91 of this catalog.	
3	Motor electromagnetic brake cable: Select one from the following (1) to (6).						
	10m or shorter (Direct connection type)	IP65	Lead out in direction of motor shaft	Long bending life	(1)	MR-BKS1CBL□M-A1-H	Refer to item ⑰ on page 92 of this catalog.
				Standard	(2)	MR-BKS1CBL□M-A1-L	
			Lead out in opposite direction of motor shaft	Long bending life	(3)	MR-BKS1CBL□M-A2-H	Refer to item ⑱ on page 92 of this catalog.
				Standard	(4)	MR-BKS1CBL□M-A2-L	
	Exceeding 10m (Relay type)	IP55	Lead out in direction of motor shaft	Standard	(5)	Use a user-manufactured cable connected to MR-BKS2CBL03M-A1-L (optional cable).	Refer to item ⑲ on page 92 of this catalog.
Lead out in opposite direction of motor shaft			Standard	(6)	Use a user-manufactured cable connected to MR-BKS2CBL03M-A2-L (optional cable).	Refer to item ⑳ on page 92 of this catalog.	
4	Encoder cable: Select one from the following (1) to (2).						
	IP67	Long bending life		(1)	MR-J3ENCBL□M-H	Refer to item ⑦ on page 91 of this catalog.	
Standard		(2)	MR-J3ENCBL□M-L				
5	Motor power supply cable: Select one from the following (1) to (3).						
	IP67	For HF-SP51, 81 HF-SP52(4), 102(4), 152(4)		(1)	Manufacture a cable using MR-PWCNS4 (optional connector).	Refer to item ⑭ on page 92 of this catalog.	
		For HF-SP121, 201, 301 HF-SP202(4), 352(4), 502(4)		(2)	Manufacture a cable using MR-PWCNS5 (optional connector).	Refer to item ⑮ on page 92 of this catalog.	
For HF-SP421, 702(4)		(3)	Manufacture a cable using MR-PWCNS3 (optional connector).	Refer to item ⑯ on page 92 of this catalog.			
6	Motor electromagnetic brake cable				Manufacture a cable using MR-BKCNS1 (optional connector).		
7	Motor power supply cable: Select one from the following (1) to (3).						
	IP65, IP67	For HC-LP52, 102, 152 HC-RP103, 153, 203 HC-UP72, 152		(1)	Manufacture a cable using MR-PWCNS1 (optional connector).	Refer to item ⑰ on page 92 of this catalog.	
		For HC-LP202, 302 HC-RP353, 503 HC-UP202, 352, 502 HA-LP502		(2)	Manufacture a cable using MR-PWCNS2 (optional connector).	Refer to item ⑱ on page 92 of this catalog.	
For HA-LP702		(3)	Manufacture a cable using MR-PWCNS3 (optional connector).	Refer to item ⑲ on page 92 of this catalog.			
8	Motor electromagnetic brake cable				Manufacture a cable using MR-BKCN (optional cable).		

# Options

## ● Cables and connectors for MR-J3-A

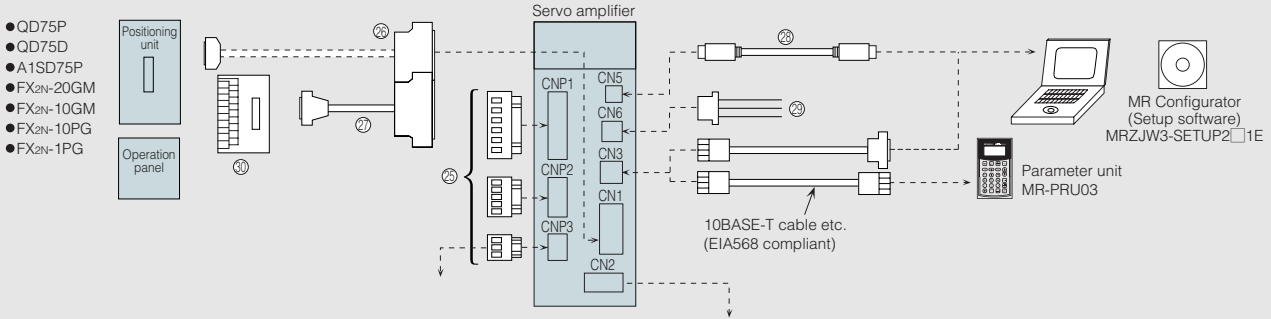

### <For HF-KP/HF-MP servo motor series: encoder cable length 10m or shorter>

● For leading the cables out in a direction of the motor shaft

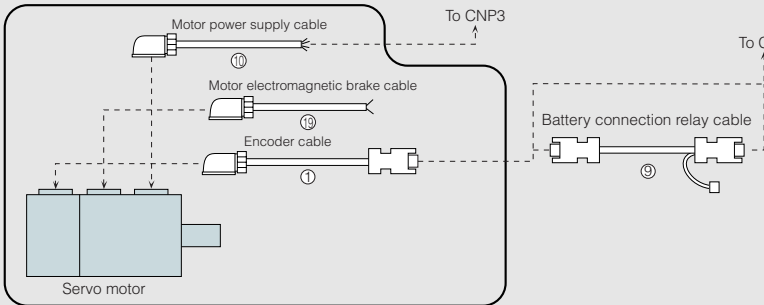

● For leading the cables out in an opposite direction of the motor shaft

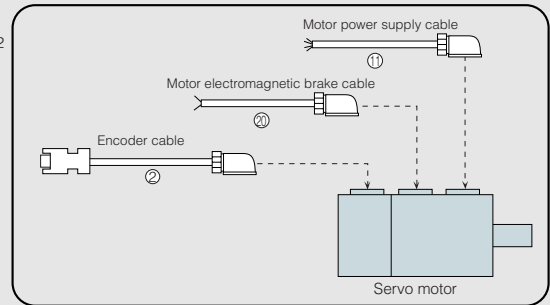

### <For HF-KP/HF-MP servo motor series: encoder cable length over 10m>

● For leading the cables out in a direction of the motor shaft

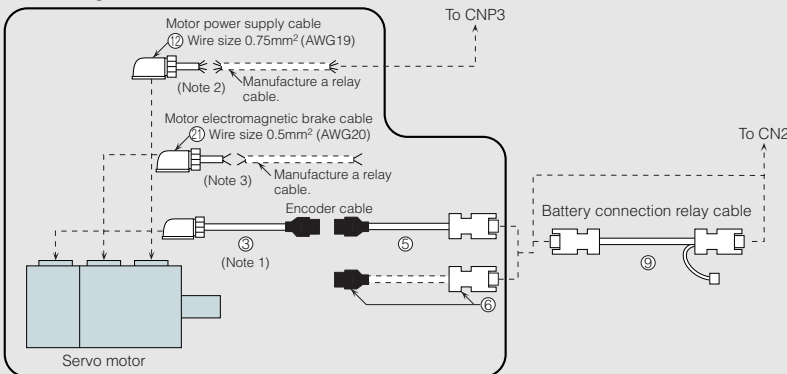

● For leading the cables out in an opposite direction of the motor shaft

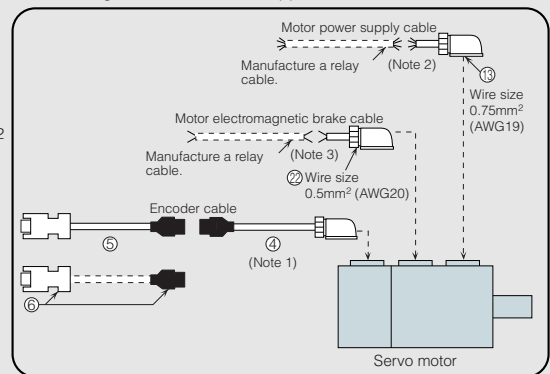

Notes:1. This cable does not have a long bending life, so always fix the cable before using.

2. If the length exceeds 10m, relay a cable using the cable MR-PWS2CBL03M-A1-L/-A2-L. This cable does not have a long bending life, so always fix the cable before using. Refer to "MR-J3-□A SERVO AMPLIFIER INSTRUCTION MANUAL" for details on manufacturing the relay cable.

3. If the length exceeds 10m, relay a cable using the cable MR-BKS2CBL03M-A1-L/-A2-L. This cable does not have a long bending life, so always fix the cable before using. Refer to "MR-J3-□A SERVO AMPLIFIER INSTRUCTION MANUAL" for details on manufacturing the relay cable.

### <For HF-SP servo motor series>

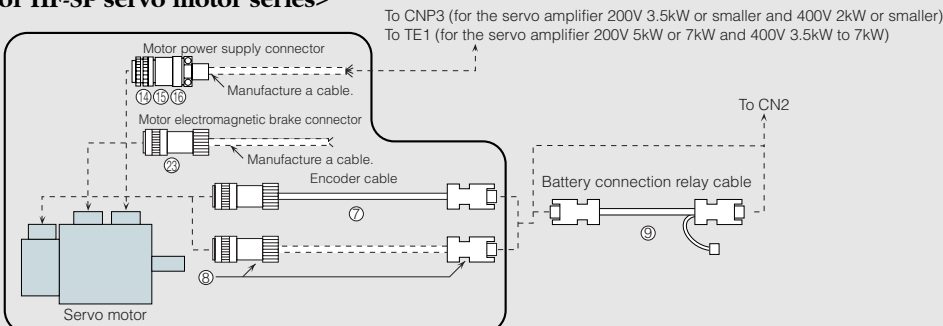

## ● Cables and connectors for MR-J3-A

### <For HC-LP/HC-RP/HC-UP servo motor series or HA-LP502/702>

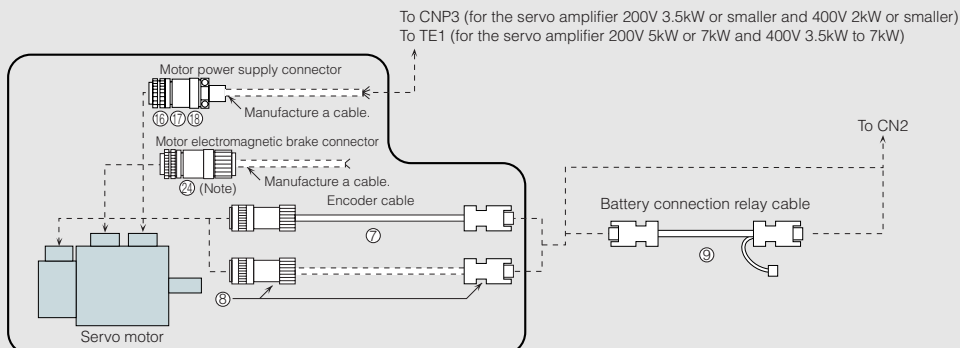

Note: The electromagnetic cable is not required for 1.5kW or smaller servo motors of HC-LP series and of HC-UP series as the power supply connector has electromagnetic brake terminals.

### <For HA-LP servo motor series 22kW or smaller (Note 1)>

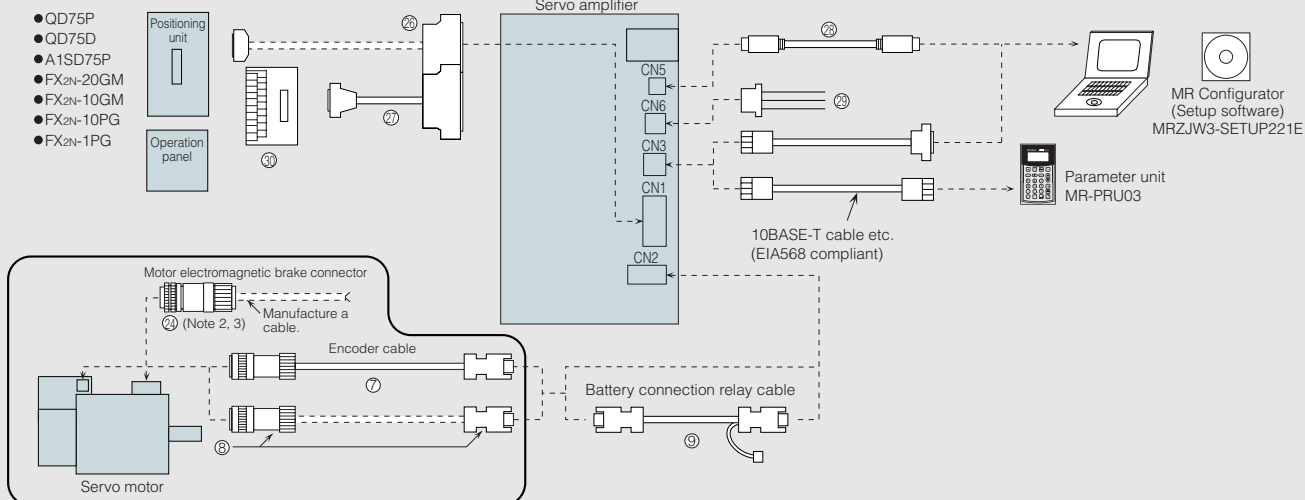





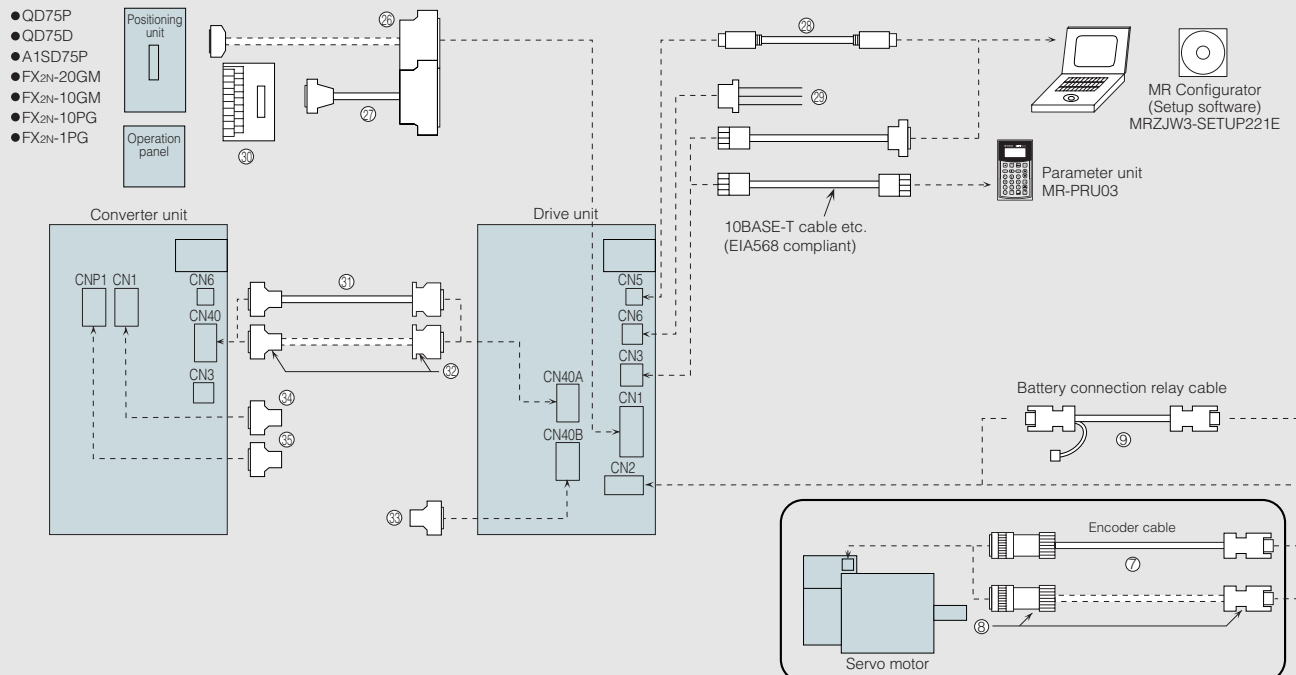

Notes: 1. HA-LP502 and 702 are excluded.  
2. The servo motors with an electromagnetic brake are available in 12kW or smaller for HA-LP 1000r/min series, 15kW or smaller for HA-LP 1500r/min series and 11 to 22kW for HA-LP 2000r/min series.  
3. For connectors in general-environment use, refer to the section "Ordering information for Customers".

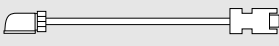
### <For HA-LP servo motor series 30kW or larger>

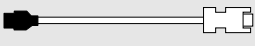
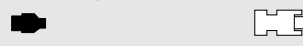

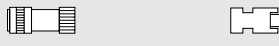
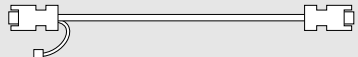







## ● Cables and connectors for MR-J3-A

Item			Model	Protection level	Description	
Encoder cables and connector sets for CN2	①	10m or shorter (Direct connection type)	Encoder cable for HF-KP/HF-MP series Lead out in direction of motor shaft	MR-J3ENCBL□M-A1-H □=cable length: 2, 5, 10m (Note 1)	IP65	Encoder connector (Tyco Electronics AMP) 1674320-1 
			MR-J3ENCBL□M-A1-L □=cable length: 2, 5, 10m (Note 1)	IP65		
	②	Encoder cable for HF-KP/HF-MP series Lead out in opposite direction of motor shaft	MR-J3ENCBL□M-A2-H □=cable length: 2, 5, 10m (Note 1)	IP65		
			MR-J3ENCBL□M-A2-L □=cable length: 2, 5, 10m (Note 1)	IP65		
	③	Exceeding 10m (Relay type)	Motor-side encoder cable for HF-KP/HF-MP series Lead out in direction of motor shaft	MR-J3JCBL03M-A1-L Cable length: 0.3m (Note 1)	IP20	Encoder connector (Tyco Electronics AMP) 1674320-1 
			Motor-side encoder cable for HF-KP/HF-MP series Lead out in opposite direction of motor shaft	MR-J3JCBL03M-A2-L Cable length: 0.3m (Note 1)	IP20	
	⑤	Exceeding 10m (Relay type)	Amplifier-side encoder cable for HF-KP/HF-MP series	MR-EKCBL□M-H □=cable length: 20, 30, 40, 50m (Note 1)	IP20	Junction connector (Tyco Electronics AMP) 1-172161-9 (housing) 170359-1 (connector pin) MTI-0002 (cable clamp, TOA ELECTRIC INDUSTRIAL) 
				MR-EKCBL□M-L □=cable length: 20, 30m (Note 1)	IP20	
	⑥	Exceeding 10m (Relay type)	Junction connector, Amplifier connector (Note 2) for HF-KP/HF-MP series	MR-ECNM	IP20	Junction connector (Tyco Electronics AMP) 1-172161-9 (housing) 170359-1 (connector pin) MTI-0002 (cable clamp, TOA ELECTRIC INDUSTRIAL)  Amplifier connector 36210-0100PL (receptacle, 3M) 36310-3200-008 (shell kit, 3M), or 54599-1019 (connector set, Molex)  <Applicable cable example> Wire size: 0.3mm <sup>2</sup> (AWG22) Completed cable outer diameter: φ8.2mm Crimping tool (91529-1) is required.  Use these in combination of ③ or ④.
	⑦	Encoder cable for HF-SP/HC-LP/HC-RP/HC-UP/HA-LP series	MR-J3ENSCBL□M-H □=cable length: 2, 5, 10, 20, 30, 40, 50m (Note 1)	IP67	Encoder connector (DDK) <For 10m or shorter cable> CM10-SP10S-M (straight plug) CM10-#22SC(C1)-100 (socket contact) 	
			MR-J3ENSCBL□M-L □=cable length: 2, 5, 10, 20, 30m (Note 1)	IP67		
	⑧	Encoder connector set for HF-SP/HC-LP/HC-RP/HC-UP/HA-LP series	MR-J3SCNS	IP67	Encoder connector (DDK) CM10-SP10S-M (straight plug) CM10-#22SC(S1)-100 (socket contact)  <Applicable cable example> Wire size: 0.5mm <sup>2</sup> (AWG20) or smaller Completed cable outer diameter: φ6.0 to 9.0mm Amplifier connector 36210-0100PL (receptacle, 3M) 36310-3200-008 (shell kit, 3M), or 54599-1019 (connector set, Molex)	
⑨	Battery connection relay cable	MR-J3BTCBL03M Cable length: 0.3m (Note 4)	—	Amplifier CN2 connector (3M or an equivalent product) (Note 3) 36210-0100PL (receptacle) 36310-3200-008 (shell kit)  Battery connector (HIROSE ELECTRIC) DF3-2EP-2C (plug) DF3-EP2428PCA (Crimping terminal for plug) 2 pcs. Not required when the servo system is used in incremental mode. Refer to the section "Options ● Battery connection relay cable" for details. Junction connector (3M) 36110-3000FD (plug) 36310-F200-008 (shell kit)		
Select one from ⑩ to ⑬ for the motor power supply	⑩	10m or shorter (Direct connection type)	Power supply cable for HF-KP/HF-MP series Lead out in direction of motor shaft	MR-PWS1CBL□M-A1-H □=cable length: 2, 5, 10m (Note 1)	IP65	Motor power supply connector (Japan Aviation Electronics Industry) JN4FT04SJ1-R (plug) ST-TMH-S-C1B-100-(A534G) (socket contact) 
			MR-PWS1CBL□M-A1-L □=cable length: 2, 5, 10m (Note 1)	IP65		
	⑪	Power supply cable for HF-KP/HF-MP series Lead out in opposite direction of motor shaft	MR-PWS1CBL□M-A2-H □=cable length: 2, 5, 10m (Note 1)	IP65		
			MR-PWS1CBL□M-A2-L □=cable length: 2, 5, 10m (Note 1)	IP65		
	⑫	Exceeding 10m (Relay type)	Power supply cable for HF-KP/HF-MP series Lead out in direction of motor shaft	MR-PWS2CBL03M-A1-L Cable length: 0.3m (Note 1)	IP55	
⑬	Exceeding 10m (Relay type)	Power supply cable for HF-KP/HF-MP series Lead out in opposite direction of motor shaft	MR-PWS2CBL03M-A2-L Cable length: 0.3m (Note 1)	IP55	Motor power supply connector (Japan Aviation Electronics Industry) JN4FT04SJ2-R (plug) ST-TMH-S-C1B-100-(A534G) (socket contact)  Lead-out	

- Notes: 1. -H and -L indicate a bending life. -H indicates a long bending life, and -L indicates a standard bending life.  
 2. Refer to "MR-J3 SERVO AMPLIFIER INSTRUCTION MANUAL" for details on manufacturing the cable.  
 3. Molex connector can be used for the amplifier CN2 connector. Model: 54599-1019 (connector set)  
 4. The battery connection relay cable (MR-J3BTCBL03M) has a diode built-in. Do not manufacture this cable. This optional cable must be used.

## ● Cables and connectors for MR-J3-A

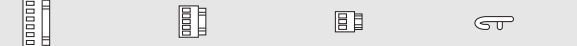
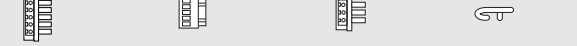
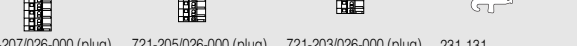
Item		Model	Protection level	Description	
Select one from ⑩ to ⑱ for the motor power supply	⑭	Power supply connector for HF-SP51, 81, HF-SP52, 102, 152, HF-SP524, 1024, 1524	MR-PWCNS4 (Straight type)	IP67  Motor power supply connector (DDK) CE05-6A18-10SD-D-BSS (plug) (straight) CE3057-10A-1-D (cable clamp) <Applicable cable example> Wire size: 2mm <sup>2</sup> (AWG14) to 3.5mm <sup>2</sup> (AWG12) Completed cable outer diameter: φ10.5 to 14.1mm	
	⑮	Power supply connector for HF-SP121, 201, 301 HF-SP202, 352, 502, HF-SP2024, 3524, 5024	MR-PWCNS5 (Straight type)	IP67  Motor power supply connector (DDK) CE05-6A22-22SD-D-BSS (plug) (straight) CE3057-12A-1-D (cable clamp) <Applicable cable example> Wire size: 5.5mm <sup>2</sup> (AWG10) to 8mm <sup>2</sup> (AWG8) Completed cable outer diameter: φ12.5 to 16mm	
	⑯	Power supply connector for HF-SP421, 702, 7024 HA-LP702	MR-PWCNS3 (Straight type)	IP67  Motor power supply connector (DDK) CE05-6A32-17SD-D-BSS (plug) (straight) CE3057-20A-1-D (cable clamp) <Applicable cable example> Wire size: 14mm <sup>2</sup> (AWG6) to 22mm <sup>2</sup> (AWG4) Completed cable outer diameter: φ22 to 23.8mm	
	⑰	Power supply connector for HC-LP52, 102, 152, HC-RP103, 153, 203, HC-UP72, 152	MR-PWCNS1 (Straight type)	IP65  Motor power supply connector (DDK) CE05-6A22-23SD-D-BSS (plug) (straight) CE3057-12A-2-D (cable clamp) <Applicable cable example> Wire size: 2mm <sup>2</sup> (AWG14) to 3.5mm <sup>2</sup> (AWG12) Completed cable outer diameter: φ9.5 to 13mm	
	⑱	Power supply connector for HC-LP202, 302, HC-RP353, 503, HC-UP202, 352, 502, HA-LP502	MR-PWCNS2 (Straight type)	IP65  Motor power supply connector (DDK) CE05-6A24-10SD-D-BSS (plug) (straight) CE3057-16A-2-D (cable clamp) <Applicable cable example> Wire size: 5.5mm <sup>2</sup> (AWG10) to 8mm <sup>2</sup> (AWG8) Completed cable outer diameter: φ13 to 15.5mm	
Select one for the motor electromagnetic brake	⑲	10m or shorter (Direct connection type)	MR-BKS1CBL□M-A1-H □=cable length: 2, 5, 10m (Note 1)	IP65	Motor brake connector (Japan Aviation Electronics Industry) JN4FT02SJ1-R (plug) ST-TMH-S-C1B-100-(A534G) (socket contact)  Lead-out
			MR-BKS1CBL□M-A1-L □=cable length: 2, 5, 10m (Note 1)	IP65	
	⑳	Brake cable for HF-KP/HF-MP series Lead out in opposite direction of motor shaft	MR-BKS1CBL□M-A2-H □=cable length: 2, 5, 10m (Note 1)	IP65	
			MR-BKS1CBL□M-A2-L □=cable length: 2, 5, 10m (Note 1)	IP65	
	㉑	Exceeding 10m (Relay type)	MR-BKS2CBL03M-A1-L Cable length: 0.3m (Note 1)	IP55	Motor brake connector (Japan Aviation Electronics Industry) JN4FT02SJ2-R (plug) ST-TMH-S-C1B-100-(A534G) (socket contact)  Lead-out
			MR-BKS2CBL03M-A2-L Cable length: 0.3m (Note 1)	IP55	
	㉒	Brake connector for HF-SP series	MR-BKCNS1 (Straight type)	IP67  Motor brake connector (DDK) (soldered type) CM10-SP2S-L (straight plug), CM10-#22SC(S2)-100 (socket contact) <Applicable cable example> Wire size: 1.25mm <sup>2</sup> (AWG16) or smaller Completed cable outer diameter: φ9.0 to 11.6mm	
㉓	Brake connector for HC-LP202B, 302B, HC-UP202B, 352B, 502B, HA-LP601B, 801B, 12K1B, 6014B, 8014B, 12K14B, HA-LP701MB, 11K1MB, 15K1MB, 701M4B, 11K1M4B, 15K1M4B, HA-LP11K2B, 15K2B, 22K2B, 11K24B, 15K24B, 22K24B	MR-BKCN (Straight type)	IP65  Motor brake connector D/MS3106A10SL-4S(D190) (plug, DDK) YSO10-5 to 8 (cable connector (straight), Daiwa Dengyo) <Applicable cable example> Wire size: 0.3mm <sup>2</sup> (AWG22) to 1.25mm <sup>2</sup> (AWG16) Completed cable outer diameter: φ5 to 8.3mm		
For CNP1, CNP2, CNP3	Amplifier power supply connector set (Note 3)	For 1kW or smaller (100VAC/200VAC)	(Standard accessory: Insertion type)	—	CNP1 connector    CNP2 connector    CNP3 connector    Insertion tool  54928-0670 (connector) (Molex or an equivalent product)    54927-0520 (connector) (Molex or an equivalent product)    54928-0370 (connector) (Molex or an equivalent product)    54932-0000 (Molex or an equivalent product) <Applicable cable example> (Note 2) Wire size: 0.14mm <sup>2</sup> (AWG26) to 2.5mm <sup>2</sup> (AWG14) Completed cable outer diameter: up to φ3.8mm
		For 2kW, 3.5kW (200VAC)			CNP1 connector    CNP2 connector    CNP3 connector    Insertion tool  PC4/6-STF-7.62-CRW (connector) (PHOENIX or an equivalent product)    54927-0520 (connector) (Molex or an equivalent product)    PC4/3-STF-7.62-CRW (connector) (PHOENIX or an equivalent product)    54932-0000 (Molex or an equivalent product) <Applicable cable example> (Note 2) Wire size: 0.2mm <sup>2</sup> (AWG24) to 5.5mm <sup>2</sup> (AWG10) Completed cable outer diameter: up to φ5mm
		For 2kW or smaller (400VAC)			CNP1 connector    CNP2 connector    CNP3 connector    Insertion tool  721-207/026-000 (plug) (WAGO or an equivalent product)    721-205/026-000 (plug) (WAGO or an equivalent product)    721-203/026-000 (plug) (WAGO or an equivalent product)    231-131 (WAGO or an equivalent product) <Applicable cable example> (Note 2) Wire size: 0.08mm <sup>2</sup> (AWG28) to 2mm <sup>2</sup> (AWG14) Completed cable outer diameter: up to φ4.1mm

Notes: 1. -H and -L indicate a bending life. -H indicates a long bending life, and -L indicates a standard bending life.  
 2. Refer to the section "Peripheral Equipment ● Electrical wires, circuit breakers, magnetic contactors" in this catalog for details on recommended electrical wire size.  
 3. The connector type terminal blocks are available for 100V/200V 3.5kW or smaller and 400V 2kW or smaller servo amplifiers. For 200V 5kW or larger and 400V 3.5kW or larger, screw type connector blocks are used.

# Options

## ● Cables and connectors for MR-J3-A

Item		Model	Protection level	Description
For CN1	②⑥	CN1 connector	MR-J3CN1	— Amplifier connector (3M or an equivalent product) 10150-3000PE (connector) 10350-52F0-008 (shell kit)
	②⑦	Junction terminal block cable	MR-J2M-CN1TBL□M □=cable length: 0.5, 1m	— Junction terminal block connector (3M)  Amplifier connector (3M or an equivalent product) 10150-6000EL (connector) 10350-3210-000 (shell kit) (Note 1) D7950-B500FL (connector)
For CN5	②⑧ Personal computer communication cable USB cable	MR-J3USBCBL3M Cable length: 3m	—	Amplifier connector mini-B connector (5 pins)  Personal computer connector A connector
For CN6	②⑨ Monitor cable	MR-J3CN6CBL1M Cable length: 1m	—	Amplifier connector (Molex) 51004-0300 (housing) 50011-8100 (terminal)
	③⑩ Junction terminal block	MR-TB50	—	
For drive unit CN40A, and converter unit CN40	③① Protection coordination cable	MR-J3CDL05M Cable length: 0.5m	—	Converter unit connector (3M or an equivalent product) 10120-3000PE (connector) 10320-52F0-008 (shell kit) (Note 2)  Drive unit connector (HONDA TSUSHIN KOGYO) PCR-S20FS+(connector) PCR-LS20LA1 (case)
	③② Connector set	MR-J2CN1-A	—	Converter unit connector (3M or an equivalent product) 10120-3000PE (connector) 10320-52F0-008 (shell kit) (Note 2)  Drive unit connector (HONDA TSUSHIN KOGYO) PCR-S20FS+(connector) PCR-LS20LA1 (case)
For drive unit CN40B	③③ Terminal connector	MR-J3-TM	—	Terminal connector
For converter unit	③④ Control signal connector (for CN1)	(Standard accessory)	—	Converter unit connector (DDK) 17JE23090-02(D8A)K11-CG (connector)
	③⑤ Magnetic contactor control connector (for CNP1)	(Standard accessory)	—	Converter unit connector (PHOENIX) GMSTBV 2.5/2-GF-7.62 (socket)

Notes: 1. The connector and the shell kit are press bonding type. Models for soldered type are 10150-3000PE (connector) and 10350-52F0-008 (shell kit).  
2. The connector and the shell kit are soldered type. Models for press bonding type are 10120-6000EL (connector) and 10320-3210-000 (shell kit).

## ● Cables and connectors for MR-J3-B

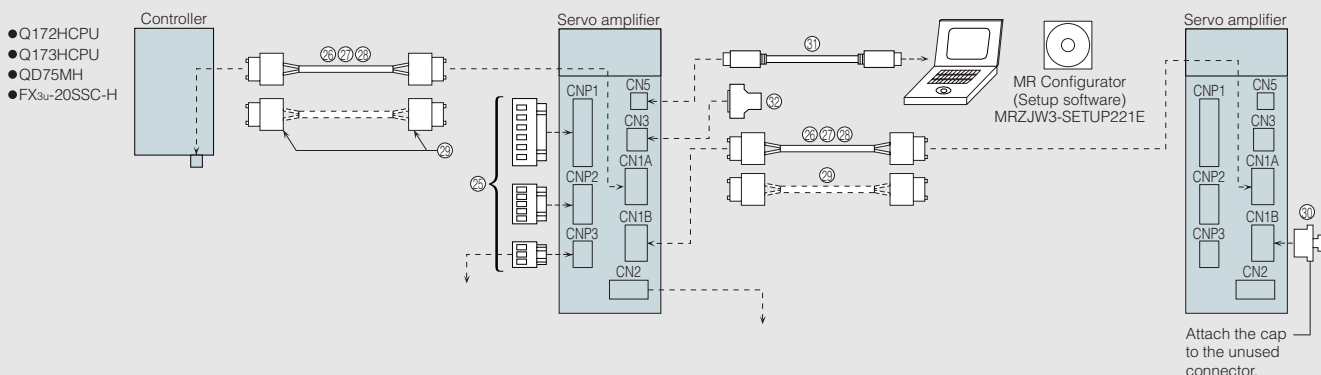

### <For HF-KP/HF-MP servo motor series: encoder cable length 10m or shorter>

● For leading the cables out in a direction of the motor shaft

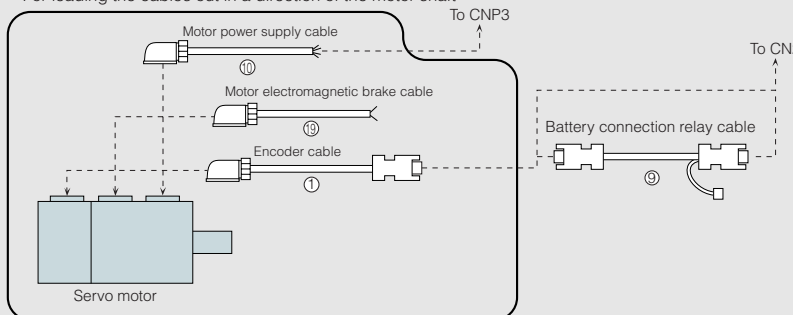

● For leading the cables out in an opposite direction of the motor shaft

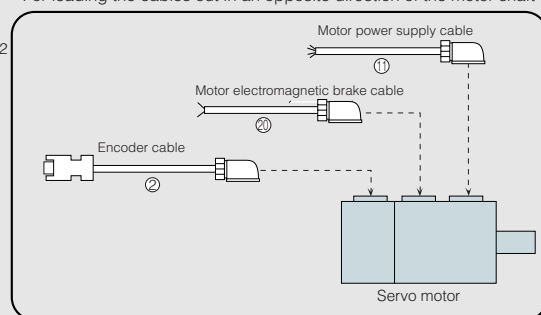

### <For HF-KP/HF-MP servo motor series: encoder cable length over 10m>

● For leading the cables out in a direction of the motor shaft

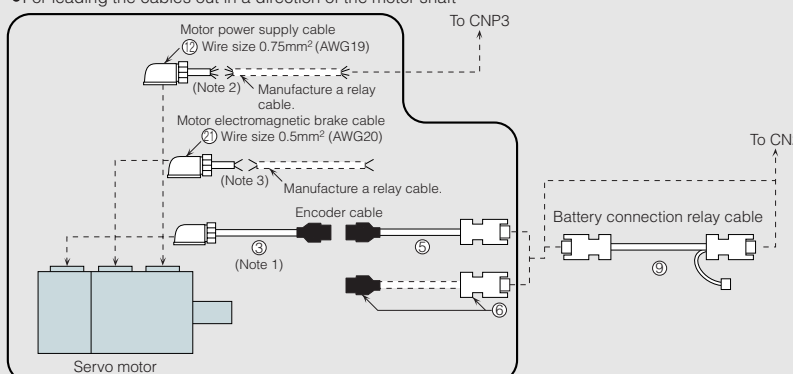

● For leading the cables out in an opposite direction of the motor shaft

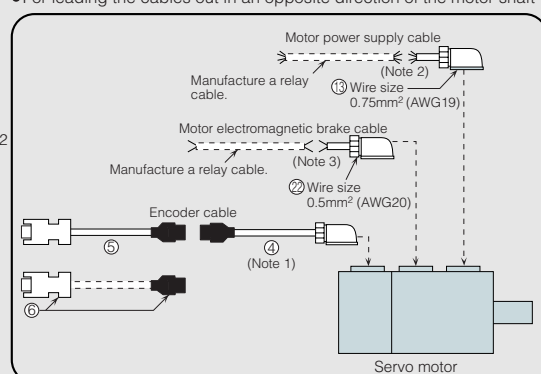

- Notes: 1. This cable does not have a long bending life, so always fix the cable before using.  
 2. If the length exceeds 10m, relay a cable using the cable MR-PWS2CBL03M-A1-L/-A2-L. This cable does not have a long bending life, so always fix the cable before using. Refer to "MR-J3-□B SERVO AMPLIFIER INSTRUCTION MANUAL" for details on manufacturing the relay cable.  
 3. If the length exceeds 10m, relay a cable using the cable MR-BKS2CBL03M-A1-L/-A2-L. This cable does not have a long bending life, so always fix the cable before using. Refer to "MR-J3-□B SERVO AMPLIFIER INSTRUCTION MANUAL" for details on manufacturing the relay cable.

### <For HF-SP servo motor series>

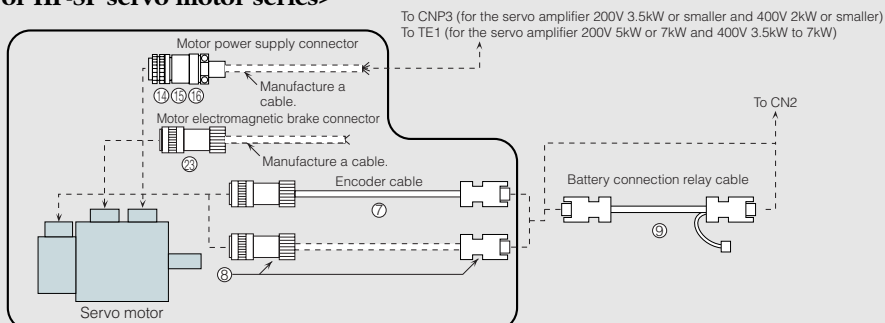

# Options

## ● Cables and connectors for MR-J3-B

### <For HC-LP/HC-RP/HC-UP servo motor series or HA-LP502/702>

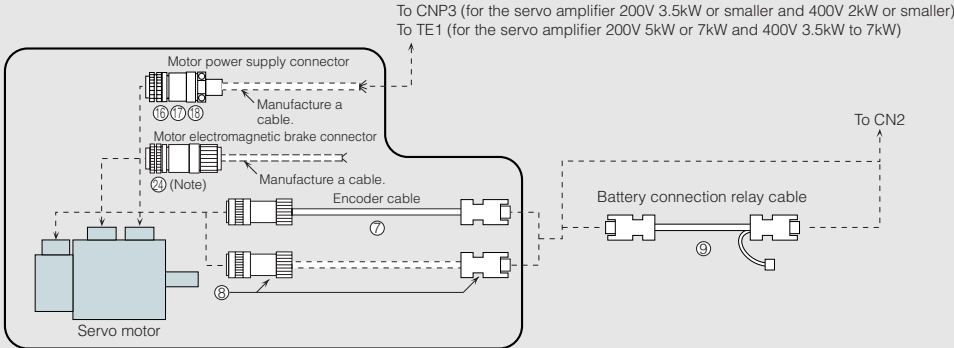

Note: The electromagnetic cable is not required for 1.5kW or smaller servo motors of HC-LP series and of HC-UP series as the power supply connector has electromagnetic brake terminals.

### <For HA-LP servo motor series 22kW or smaller (Note 1)>

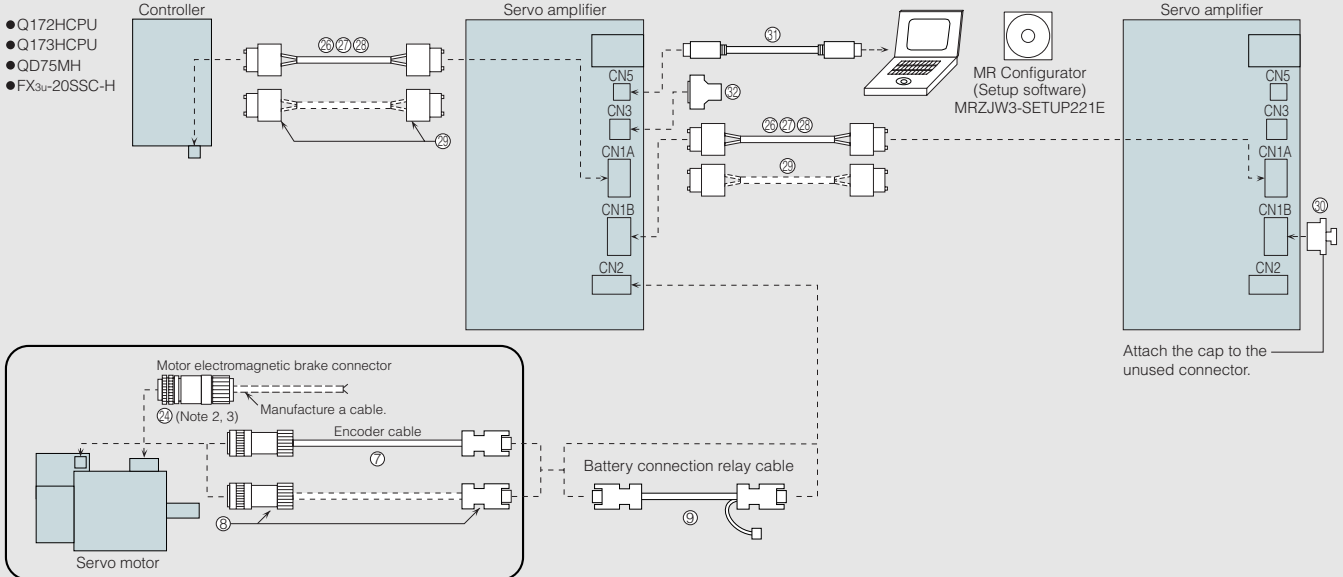

Notes: 1. HA-LP502 and 702 are excluded.  
2. The servo motors with an electromagnetic brake are available in 12kW or smaller for HA-LP 1000r/min series, 15kW or smaller for HA-LP 1500r/min series and 11 to 22kW for HA-LP 2000r/min series.  
3. For connectors in general-environment use, refer to the section "Ordering information for Customers".



## ● Cables and connectors for MR-J3-B

<For HA-LP servo motor series 30kW or larger>

- Q172HCPU
- Q173HCPU
- QD75MH
- FX3u-20SSC-H

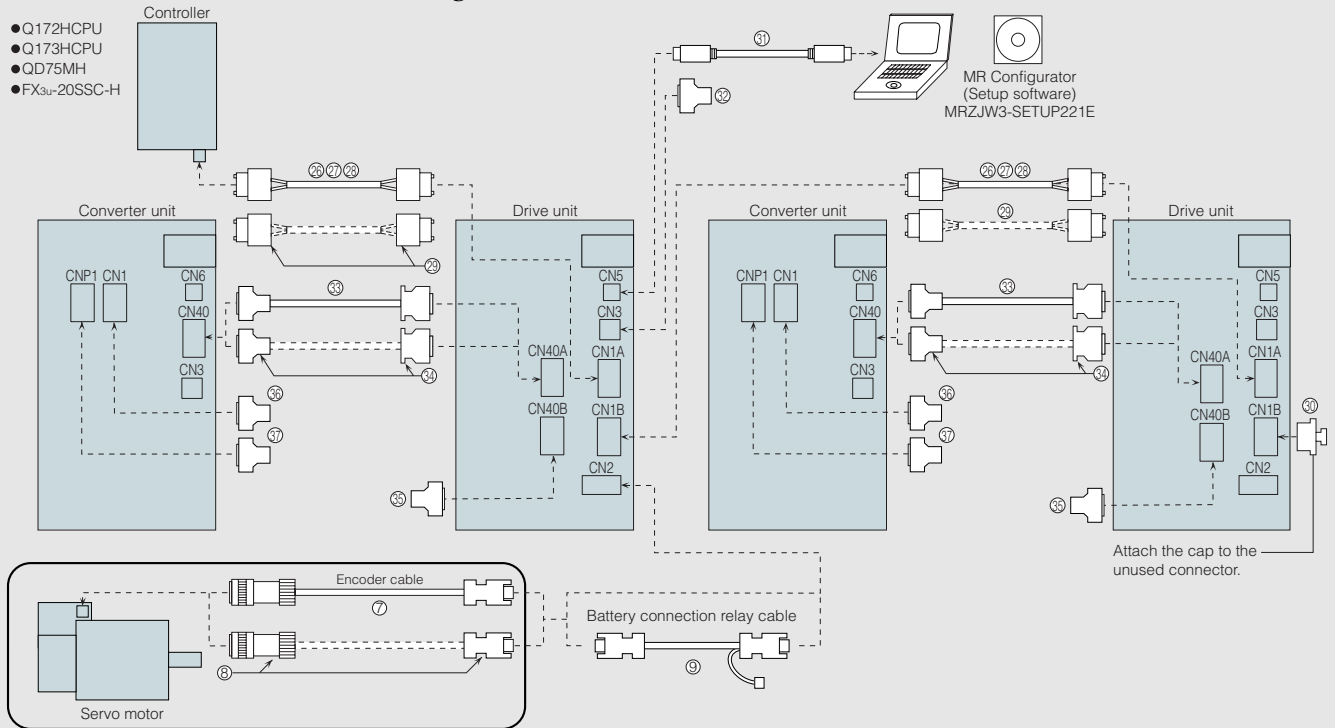





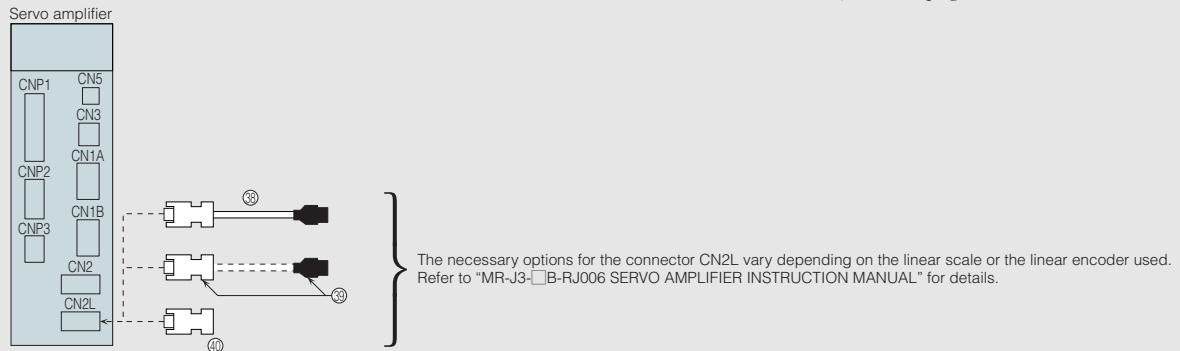

## <For MR-J3-□B□-RJ006>

For options other than for the connector CN2L, refer to the section "Cable and connectors for MR-J3-B" on page 95 and 96 in this catalog.

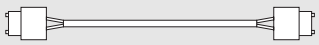

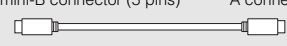
## ● Cables and connectors for MR-J3-B

Encoder cables, battery connection relay cable, power supply cables, brake cables, and servo amplifier power supply connector set from ① to ②⑤ are same as for MR-J3-A. Refer to page 91 and 92 in this catalog.

Item		Model	Protection level	Description		
For controller, CN1A, CN1B	②⑥	SSCNET III cable (Standard cord for inside panel)	MR-J3BUS□M □=cable length: 0.15, 0.3, 0.5, 1, 3m	—	Connector (Japan Aviation Electronics Industry) PF-2D103 (connector)      Connector (Japan Aviation Electronics Industry) PF-2D103 (connector)	
	②⑦	SSCNET III cable (Standard cable for outside panel)	MR-J3BUS□M-A □=cable length: 5, 10, 20m	—		
	②⑧	SSCNET III cable (Long distance cable) (Note 2)	MR-J3BUS□M-B □=cable length: 30, 40, 50m	—	Connector (Japan Aviation Electronics Industry) CF-2D103-S (connector)      Connector (Japan Aviation Electronics Industry) CF-2D103-S (connector)	
	②⑨	Connector set for SSCNET III	MR-J3BCN1 (Note 3)	—	Connector (Japan Aviation Electronics Industry) PF-2D103 (connector)      Connector (Japan Aviation Electronics Industry) PF-2D103 (connector)	
For CN1B	③⑩	Connector cap for SSCNET III	(Standard accessory)	—		
For CN5	③①	Personal computer communication cable	USB cable	MR-J3USBCBL3M Cable length: 3m	—	Amplifier connector mini-B connector (5 pins)      Personal computer connector A connector  Note: This cable cannot be used with the SSCNET III compatible controller.
For CN3	③②	Input/output signal connector	MR-CCN1	—	 Amplifier connector (3M or an equivalent product) 10120-3000PE (connector) 10320-52F0-008 (shell kit) (Note 1)	
For drive unit CN40A and converter unit CN40	③③	Protection coordination cable	MR-J3CDL05M Cable length: 0.5m	—	Converter unit connector (3M or an equivalent product) 10120-3000PE (connector) 10320-52F0-008 (shell kit) (Note 1)      Drive unit connector (HONDA TSUSHIN KOGYO) PCR-S20FS+(connector) PCR-LS20LA1 (case)	
	③④	Connector set	MR-J2CN1-A	—	Converter unit connector (3M or an equivalent product) 10120-3000PE (connector) 10320-52F0-008 (shell kit) (Note 1)      Drive unit connector (HONDA TSUSHIN KOGYO) PCR-S20FS+(connector) PCR-LS20LA1 (case)	
For drive unit CN40B	③⑤	Terminal connector	MR-J3-TM	—	 Terminal connector	
For converter unit	③⑥	Control signal connector (for CN1)	(Standard accessory)	—	 Converter unit connector (DDK) 17JE23090-02(D8A)K11-CG (connector)	
	③⑦	Magnetic contactor control connector (for CNP1)	(Standard accessory)	—	 Converter unit connector (PHOENIX) GMSTBV 2.5/2-GF-7.62 (socket)	
For CN2L	③⑧	CN2L cable	MR-EKCBL□M-H □=cable length: 2, 5, 10m	IP20	Amplifier connector 36210-0100PL (receptacle, 3M) 36310-3200-008 (shell kit, 3M), or 54599-1019 (connector set, Molex)      Junction connector (Tyco Electronics AMP) 1-172161-9 (housing) 170359-1 (connector pin) MTI-0002 (cable clamp, TOA ELECTRIC INDUSTRIAL)	
	③⑨	CN2L connector set	MR-ECNM	IP20	Amplifier connector 54599-1019 (connector set, Molex), or 36210-0100PL (receptacle, 3M) 36310-3200-008 (shell kit, 3M)      Junction connector (Tyco Electronics AMP) 1-172161-9 (housing) 170359-1 (connector pin) MTI-0002 (cable clamp, TOA ELECTRIC INDUSTRIAL) <Applicable cable example> Wire size: 0.3mm <sup>2</sup> (AWG22) Completed cable outer diameter: φ8.2mm Crimping tool (91529-1) is required.	
	④⑩	CN2L connector	MR-J3CN2	—	Amplifier connector 36210-0100PL (receptacle, 3M) 36310-3200-008 (shell kit, 3M), or 54599-1019 (connector set, Molex)	

Notes: 1. The connector and the shell kit are soldered type. Models for press bonding type are 10120-6000EL (connector) and 10320-3210-000 (shell kit).  
2. Contact Mitsubishi for details on cables shorter than 30m.  
3. Special tools are required. Contact Mitsubishi for details.

## ● Cables and connectors for MR-J3-T

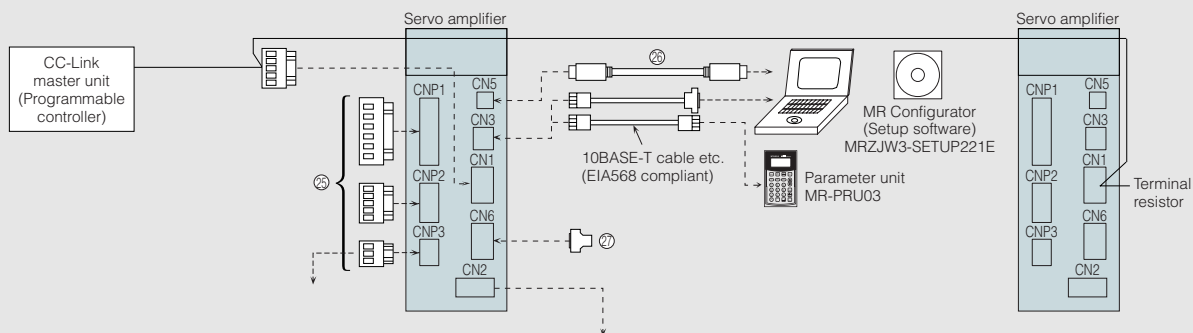

### <For HF-KP/HF-MP servo motor series: encoder cable length 10m or shorter>

● For leading the cables out in a direction of the motor shaft

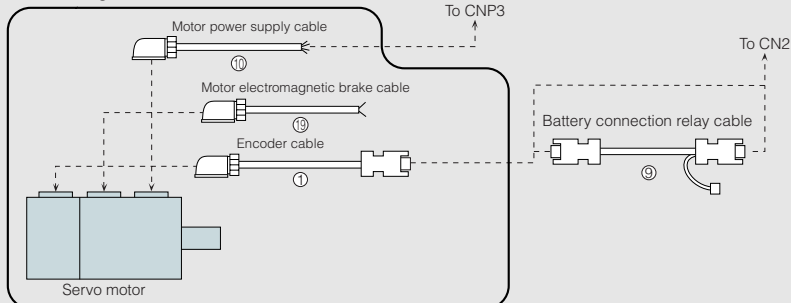

● For leading the cables out in an opposite direction of the motor shaft

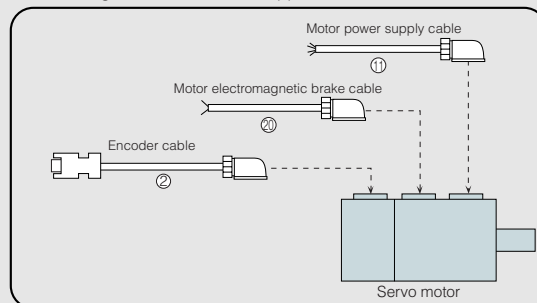

### <For HF-KP/HF-MP servo motor series: encoder cable length over 10m>

● For leading the cables out in a direction of the motor shaft

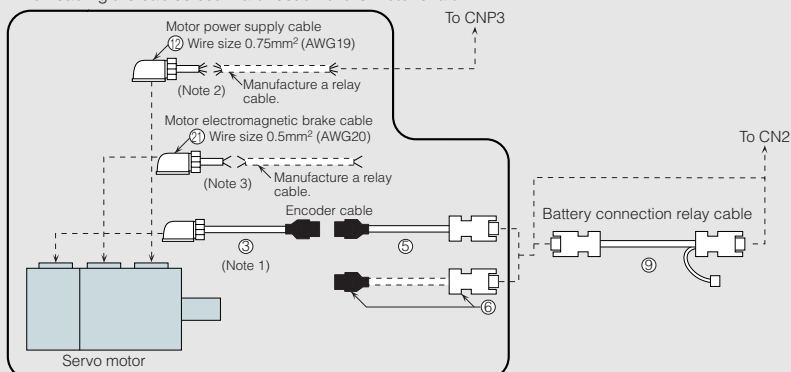

● For leading the cables out in an opposite direction of the motor shaft

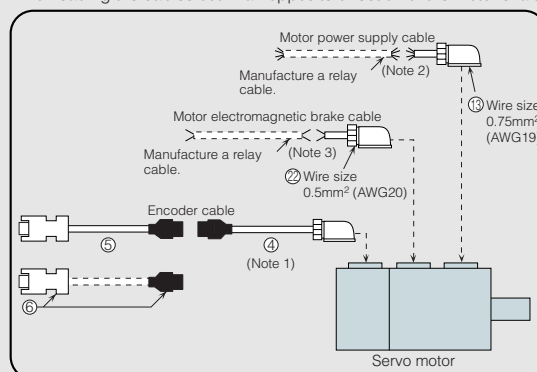

- Notes: 1. This cable does not have a long bending life, so always fix the cable before using.  
 2. If the length exceeds 10m, relay a cable using the cable MR-PWS2CBL03M-A1-L/-A2-L. This cable does not have a long bending life, so always fix the cable before using. Refer to "MR-J3-□T SERVO AMPLIFIER INSTRUCTION MANUAL" for details on manufacturing the relay cable.  
 3. If the length exceeds 10m, relay a cable using the cable MR-BKS2CBL03M-A1-L/-A2-L. This cable does not have a long bending life, so always fix the cable before using. Refer to "MR-J3-□T SERVO AMPLIFIER INSTRUCTION MANUAL" for details on manufacturing the relay cable.

### <For HF-SP servo motor series>

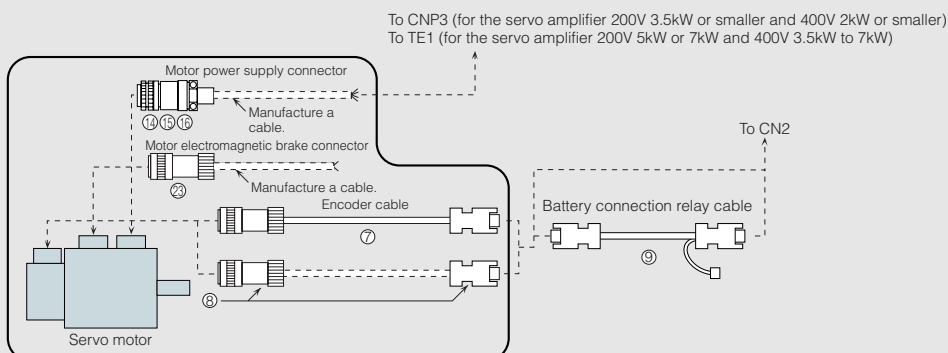

# Options

## ● Cables and connectors for MR-J3-T

### <For HC-LP/HC-RP/HC-UP servo motor series or HA-LP502/702>

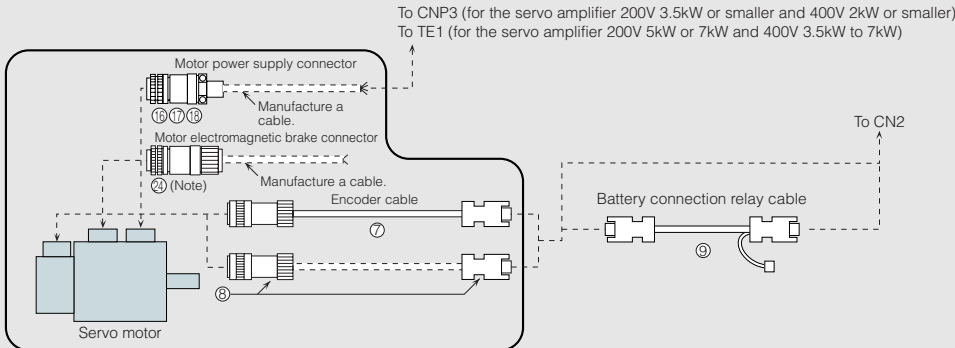

Note: The electromagnetic cable is not required for 1.5kW or smaller servo motors of HC-LP series and of HC-UP series as the power supply connector has electromagnetic brake terminals.

### <For HA-LP servo motor series (Note 1)>

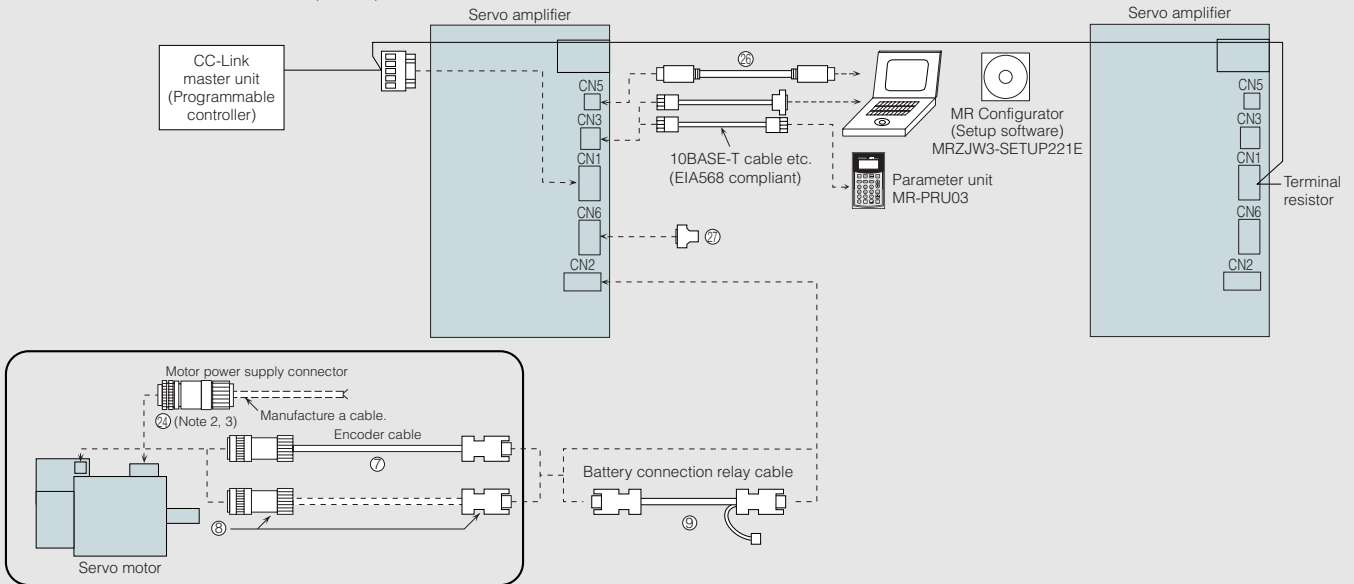

Notes: 1. HA-LP502 and 702 are excluded.  
2. The servo motors with an electromagnetic brake are available in 12kW or smaller for HA-LP 1000r/min series, 15kW or smaller for HA-LP 1500r/min series and 11 to 22kW for HA-LP 2000r/min series.  
3. For connectors in general-environment use, refer to the section "Ordering information for Customers".



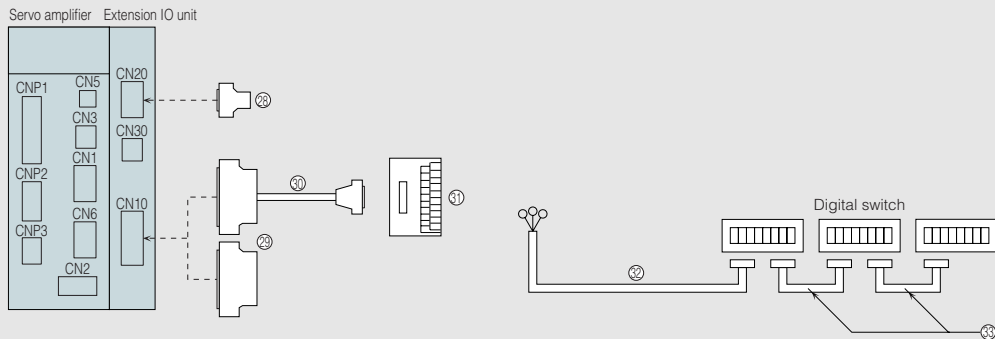



### <Using the extension IO unit MR-J3-D01 (Note)>

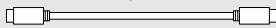

Note: Cables and connectors for the servo amplifiers are same as when the extension IO unit is not used.

### ● Cables and connectors for MR-J3-T

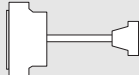
Encoder cables, battery connection relay cable, power supply cables, brake cables, and servo amplifier power supply connector set from ① to ②⑤ are same as for MR-J3-A. Refer to page 91 and 92 in this catalog.

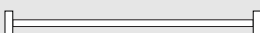
Item		Model	Protection level	Description
For CN5	②⑥ Personal computer communication cable USB cable	MR-J3USBCBL3M Cable length: 3m	—	Amplifier connector mini-B connector (5 pins)      Personal computer connector A connector 
For CN6	②⑦ CN6 connector	MR-J2CMP2	—	 Amplifier connector (3M or an equivalent product) 10126-3000PE (connector) 10326-52F0-008 (shell kit)
For CN20	②⑧ Input/output signal connector	MR-CCN1	—	 Amplifier connector (3M or an equivalent product) 10120-3000PE (connector) 10320-52F0-008 (shell kit) (Note 2)
For CN10	②⑨ Input/output signal connector	MR-J3CN1	—	 Amplifier connector (3M or an equivalent product) 10150-3000PE (connector) 10350-52F0-008 (shell kit)
	③⑩ Junction terminal block cable □=cable length: 0.5, 1m	MR-J2M-CN1TBL□M	—	Amplifier connector (3M or an equivalent product) 10150-6000EL (connector) 10350-3210-000 (shell kit) (Note 3)  Junction terminal block connector (3M) D7950-B500FL (connector)
	③① Junction terminal block	MR-TB50	—	
	③② Digital switch cable (for between MR-DS60 and MR-J3-D01)	MR-DSCBL□M-G □=cable length: 3, 5, 10m	—	
	③③ Digital switch cable (for between each MR-DS60)	MR-DSCBL□ □=cable length: 25, 100cm	—	

Notes: 1. The connector and the shell kit are press bonding type. Models for soldered type are 10120-3000PE (connector) and 10350-52F0-008 (shell kit).  
2. The connector and the shell kit are soldered type. Models for press bonding type are 10120-6000EL (connector) and 10320-3210-000 (shell kit).  
3. The connector and the shell kit are press bonding type. Models for soldered type are 10150-3000PE (connector) and 10350-52F0-008 (shell kit).

# Ordering Information for Customers

To order the following products, contact the relevant manufacturers directly.

## ● Personal computer communication cables

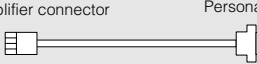
Item	Model	Protection level	Description
RS-422/RS-232C conversion cable	FA-T-RS40VS	—	 RS-422 cable    RS-422/RS-232C converter    RS-232C cable Manufacturer: MITSUBISHI ELECTRIC ENGINEERING COMPANY LIMITED
	DSV-CABV	—	 Amplifier connector    Personal computer connector Manufacturer: Diatrend Corp.

## ● RS-422 connector

Item	Model	Protection level	Description
RS-422 connector	TM10P-88P	—	 Manufacturer: HIROSE ELECTRIC CO., LTD.



## ● RS-422 distributor (for multi drop)

Item	Model	Protection level	Description
RS-422 distributor	BMJ-8	—	 Manufacturer: HACHIKO ELECTRIC CO., LTD.

## ● CC-Link twisted cable



Item	Model	Protection level	Description
CC-Link twisted cable	FANC-110SBH	—	 Manufacturer: Kuramo Electric Co., LTD.

## ● Servo amplifier power supply connectors (press bonding type) ... For 1kW or smaller



Item	Model	Protection level	Description	Applicable cable example
Amplifier CNP1 connector	51241-0600 (connector) 56125-0128 (terminal)	—	 Manufacturer: Molex	Wire size: 0.75mm <sup>2</sup> (AWG18) to 2.5mm <sup>2</sup> (AWG14) Completed cable outer diameter: up to $\phi$ 3.8mm Crimping tool (CNP57349-5300) is required.
Amplifier CNP2 connector	51240-0500 (connector) 56125-0128 (terminal)	—	 Manufacturer: Molex	
Amplifier CNP3 connector	51241-0300 (connector) 56125-0128 (terminal)	—	 Manufacturer: Molex	

## ● Encoder connectors

### <For HF-KP/HF-MP series>

Item	Model	Protection level	Description	Applicable cable example
Motor encoder connector	1674320-1	IP65	 Manufacturer: Tyco Electronics AMP K.K.	Wire size: 0.14mm <sup>2</sup> (AWG26) to 0.3mm <sup>2</sup> (AWG22) Completed cable outer diameter: $\phi$ 7.1 ± 0.3mm Crimping tools, 1596970-1 (for gland clip) and 1596847-1 (for receptacle contact), are required.
Amplifier CN2 connector (Note 1)	54599-1019 (connector set)	—	 Manufacturer: Molex	

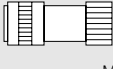
### <For HF-SP/HC-LP/HC-RP/HC-UP/HA-LP series>

Item	Connector			Contact	Protection level	Description	Applicable cable example	
	Type	Straight plug	Socket contact				Wire size	Completed cable outer diameter
Motor encoder connector	Straight	CM10-SP10S-M	CM10-#22SC(C1)-100	Press bonding type	IP67	 Manufacturer: DDK Ltd.	0.3mm <sup>2</sup> (AWG22) to 0.5mm <sup>2</sup> (AWG20) Crimping tool (357J-50446) is required.	$\phi$ 6.0 to 9.0mm
			CM10-#22SC(C2)-100				0.08mm <sup>2</sup> (AWG28) to 0.25mm <sup>2</sup> (AWG23) Crimping tool (357J-50447) is required.	
			CM10-#22SC(S1)-100	Soldered type			0.5mm <sup>2</sup> (AWG20) or smaller	
Amplifier CN2 connector (Note)	—	54599-1019 (connector set)		—	—	 Manufacturer: Molex	—	—

Note: The amplifier CN2 connector manufactured by 3M can also be used.  
 Model: 36210-0100PL (receptacle), 36310-3200-008 (shell kit).

# Ordering Information for Customers

## ● Motor power supply connectors <For HF-KP/HF-MP series>

Item	Model	Protection level	Description	Applicable cable example
Motor power supply connector	JN4FT04SJ1-R (plug) ST-TMH-S-C1B-100-(A534G) (socket contact)	IP65	 Manufacturer: Japan Aviation Electronics Industry, Ltd.	Wire size: 0.75mm <sup>2</sup> (AWG19) Completed cable outer diameter: φ6.2 ± 0.3mm Fluoric resin wire (Vinyl jacket cable FV4C <UL Style 2103> (SP3866W-X), KURABE INDUSTRIAL CO.,LTD. or an equivalent product) Crimping tool (CT160-3-TMH5B) is required.

## <For HF-SP series>

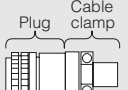
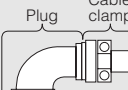
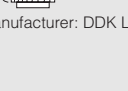
Item	Plug		Cable clamp	Protection level	Description	Applicable cable example	
	Type	Model	Model			Wire size	Completed cable outer diameter
Motor power supply connector for HF-SP51, 81, HF-SP52, 102, 152, HF-SP524, 1024, 1524	Straight	CE05-6A18-10SD-D-BSS	CE3057-10A-2-D	IP67 EN standards	<b>&lt;Straight type&gt;</b>  Manufacturer: DDK Ltd.	2mm <sup>2</sup> (AWG14) to 3.5mm <sup>2</sup> (AWG12)	φ8.5 to 11mm
		CE05-8A18-10SD-D-BAS	CE3057-10A-2-D				φ10.5 to 14.1mm
	Angled	D/MS3106B18-10S	D/MS3057-10A	General environment (Note)			φ8.5 to 11mm
		D/MS3108B18-10S	D/MS3057-10A				φ10.5 to 14.1mm
Motor power supply connector for HF-SP121, 201, 301, HF-SP202, 352, 502, HF-SP2024, 3524, 5024	Straight	CE05-6A22-22SD-D-BSS	CE3057-12A-2-D	IP67 EN standards	<b>&lt;Angled type&gt;</b>  Manufacturer: DDK Ltd.	3.5mm <sup>2</sup> (AWG12) to 8mm <sup>2</sup> (AWG8)	φ9.5 to 13mm
		CE05-8A22-22SD-D-BAS	CE3057-12A-2-D				φ12.5 to 16mm
	Angled	D/MS3106B22-22S	D/MS3057-12A	General environment (Note)			φ9.5 to 13mm
		D/MS3108B22-22S	D/MS3057-12A				φ12.5 to 16mm
Motor power supply connector for HF-SP1021, 702, HF-SP7024	Straight	CE05-6A32-17SD-D-BSS	CE3057-20A-1-D	IP67 EN standards	<b>&lt;Angled type&gt;</b>  Manufacturer: DDK Ltd.	14mm <sup>2</sup> (AWG6) to 22mm <sup>2</sup> (AWG4)	φ22 to 23.8mm
		CE05-8A32-17SD-D-BAS	CE3057-20A-1-D				φ22 to 23.8mm
	Angled	D/MS3106B32-17S	D/MS3057-20A	General environment (Note)			φ23.8mm (Inner diameter of bushing)
		D/MS3108B32-17S	D/MS3057-20A				φ23.8mm (Inner diameter of bushing)

Note: Not compliant with EN standards.

## <For HC-LP/HC-RP/HC-UP series or HA-LP502/702>

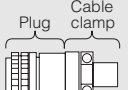
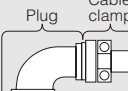
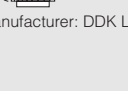
Item	Plug		Cable clamp	Protection level	Description	Applicable cable example	
	Type	Model	Model			Wire size	Completed cable outer diameter
Motor power supply connector for HC-LP52, 102, 152, HC-RP103, 153, 203, HC-UP72, 152	Straight	CE05-6A22-23SD-D-BSS	CE3057-12A-2-D	IP65 EN standards	<b>&lt;Straight type&gt;</b>  Manufacturer: DDK Ltd.	2mm <sup>2</sup> (AWG14) to 3.5mm <sup>2</sup> (AWG12)	φ9.5 to 13mm
		CE05-8A22-23SD-D-BAS	CE3057-12A-2-D				φ12.5 to 16mm
	Angled	D/MS3106B22-23S	D/MS3057-12A	General environment (Note)			φ9.5 to 13mm
		D/MS3108B22-23S	D/MS3057-12A				φ12.5 to 16mm
Motor power supply connector for HC-LP202, 302, HC-RP353, 503, HC-UP202, 352, 502, HA-LP502	Straight	CE05-6A24-10SD-D-BSS	CE3057-16A-2-D	IP65 EN standards	<b>&lt;Angled type&gt;</b>  Manufacturer: DDK Ltd.	5.5mm <sup>2</sup> (AWG10) to 8mm <sup>2</sup> (AWG8)	φ13 to 15.5mm
		CE05-8A24-10SD-D-BAS	CE3057-16A-2-D				φ15 to 19.1mm
	Angled	D/MS3106B24-10S	D/MS3057-16A	General environment (Note)			φ13 to 15.5mm
		D/MS3108B24-10S	D/MS3057-16A				φ15 to 19.1mm
Motor power supply connector for HA-LP702	Straight	CE05-6A32-17SD-D-BSS	CE3057-20A-1-D	IP65 EN standards	<b>&lt;Angled type&gt;</b>  Manufacturer: DDK Ltd.	14mm <sup>2</sup> (AWG6) to 22mm <sup>2</sup> (AWG4)	φ22 to 23.8mm
		CE05-8A32-17SD-D-BAS	CE3057-20A-1-D				φ22 to 23.8mm
	Angled	D/MS3106B32-17S	D/MS3057-20A	General environment (Note)			φ23.8mm (Inner diameter of bushing)
		D/MS3108B32-17S	D/MS3057-20A				φ23.8mm (Inner diameter of bushing)

Note: Not compliant with EN standards.

# Ordering Information for Customers

## ● Motor brake connectors <For HF-KP/HF-MP series>

Item	Model	Protection level	Description	Applicable cable example
Motor brake connector	JN4FT02SJ1-R (plug) ST-TMH-S-C1B-100-(A534G) (socket contact)	IP65	 Manufacturer: Japan Aviation Electronics Industry, Ltd.	Wire size: 0.5mm <sup>2</sup> (AWG20) Completed cable outer diameter: $\phi 4.5 \pm 0.3$ mm Fluoric resin wire (Vinyl jacket cable FV2C <UL Style 2103> (SP3866U-X), KURABE INDUSTRIAL CO.,LTD. or an equivalent product) Crimping tool (CT160-3-TMH5B) is required.

## <For HF-SP series>

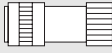
Item	Connector			Contact	Protection level	Description	Applicable cable example	
	Type	Straight plug	Socket contact				Wire size	Completed cable outer diameter
Motor brake connector	Straight	CM10-SP2S-S	CM10-#22SC(S2)-100	Soldered type	IP67	 Manufacturer: DDK Ltd.	1.25mm <sup>2</sup> (AWG16) or smaller	$\phi 4.0$ to 6.0mm
		CM10-SP2S-M						$\phi 6.0$ to 9.0mm
		CM10-SP2S-L						$\phi 9.0$ to 11.6mm
		CM10-SP2S-S	CM10-#22SC(C3)-100	Press bonding type			0.5mm <sup>2</sup> (AWG20) to 1.25mm <sup>2</sup> (AWG16) Crimping tool (357J-50448) is required.	$\phi 4.0$ to 6.0mm
		CM10-SP2S-M						$\phi 6.0$ to 9.0mm
		CM10-SP2S-L						$\phi 9.0$ to 11.6mm

## <For HC-LP/HC-UP series>

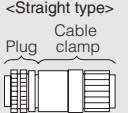
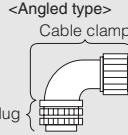
Item	Connector for cable			Plug Model	Protection level	Description	Applicable cable example	
	Type	Model	Manufacturer				Wire size	Completed cable outer diameter
Motor brake connector HC-LP202B, 302B, HC-UP202B, 352B, 502B	Straight	ACS-08RL-MS10F	NIPPON FLEX CO., LTD.	D/MS3106A10SL-4S(D190) Manufacturer: DDK Ltd.	IP65	<p>&lt;Straight type&gt;</p>  <p>&lt;Angled type&gt;</p> 	0.3mm <sup>2</sup> (AWG22) to 1.25mm <sup>2</sup> (AWG16)	$\phi 4$ to 8mm
		ACS-12RL-MS10F						$\phi 8$ to 12mm
		YSO10-5 to 8	DAIWA DENGYO CO., LTD.					$\phi 5$ to 8.3mm
	Angled	ACA-08RL-MS10F	NIPPON FLEX CO., LTD.					$\phi 4$ to 8mm
		ACA-12RL-MS10F						$\phi 8$ to 12mm
		YLO10-5 to 8	DAIWA DENGYO CO., LTD.					$\phi 5$ to 8.3mm

## <For HC-LP/HC-UP/HA-LP series>

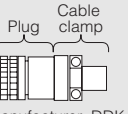
Item	Plug		Cable clamp Model	Protection level	Description	Applicable cable example	
	Type	Model				Wire size	Completed cable outer diameter
Motor brake connector HC-LP202B, 302B, HC-UP202B, 352B, 502B, HA-LP601B, 801B, 12K1B, 6014B, 8014B, 12K14B, HA-LP701MB, 11K1MB, 15K1MB, 701M4B, 11K1M4B, 15K1M4B, HA-LP11K2B, 15K2B, 22K2B, 11K24B, 15K24B, 22K24B	Straight	D/MS3106A10SL-4S	D/MS3057-4A	General environment	<p>&lt;Straight type&gt;</p>  Manufacturer: DDK Ltd.	0.3mm <sup>2</sup> (AWG22) to 1.25mm <sup>2</sup> (AWG16)	$\phi 5.6$ mm (Inner diameter of bushing)



# RoHS Compliant Connectors

## ● Optional connectors for servo amplifier

The following connector sets have been changed to RoHS compliant since September 2006.

RoHS compliant and non-RoHS compliant connector sets may be mixed based on availability.

Only the part numbers for components of the connector set that were changed after September 2006 are listed.

Connector set	Non-RoHS compliant component	RoHS compliant component
MR-J3SCNS MR-ECNM	36210-0100JL (receptacle) (Note) (3M or an equivalent product)	36210-0100PL (receptacle) (3M or an equivalent product)
MR-PWCNS4	CE05-6A18-10SD-B-BSS (connector and back shell) (DDK) CE3057-10A-1(D265) (cable clamp) (DDK)	CE05-6A18-10SD-D-BSS (connector and back shell) (DDK) CE3057-10A-1-D (cable clamp) (DDK)
MR-PWCNS5	CE05-6A22-22SD-B-BSS (connector and back shell) (DDK) CE3057-12A-1(D265) (cable clamp) (DDK)	CE05-6A22-22SD-D-BSS (connector and back shell) (DDK) CE3057-12A-1-D (cable clamp) (DDK)
MR-PWCNS3	CE05-6A32-17SD-B-BSS (connector and back shell) (DDK) CE3057-20A-1(D265) (cable clamp) (DDK)	CE05-6A32-17SD-D-BSS (connector and back shell) (DDK) CE3057-20A-1-D (cable clamp) (DDK)
MR-PWCNS1	CE05-6A22-23SD-B-BSS (connector and back shell) (DDK) CE3057-12A-2(D265) (cable clamp) (DDK)	CE05-6A22-23SD-D-BSS (connector and back shell) (DDK) CE3057-12A-2-D (cable clamp) (DDK)
MR-PWCNS2	CE05-6A24-10SD-B-BSS (connector and back shell) (DDK) CE3057-16A-2(D265) (cable clamp) (DDK)	CE05-6A24-10SD-D-BSS (connector and back shell) (DDK) CE3057-16A-2-D (cable clamp) (DDK)
MR-BKCN	MS3106A10SL-4S(D190) (plug) (DDK)	D/MS3106A10SL-4S(D190) (plug) (DDK)
MR-CCN1	10120-3000VE (connector) (3M or an equivalent product)	10120-3000PE (connector) (3M or an equivalent product)
MR-J3CN1	10150-3000VE (connector) (3M or an equivalent product)	10150-3000PE (connector) (3M or an equivalent product)
MR-J2CMP2	10126-3000VE (connector) (3M or an equivalent product)	10126-3000PE (connector) (3M or an equivalent product)
MR-J2CN1-A	10120-3000VE (connector) (3M or an equivalent product) PCR-S20FS (connector) (HONDA TSUSHIN KOGYO)	10120-3000PE (connector) (3M or an equivalent product) PCR-S20FS + (connector) (HONDA TSUSHIN KOGYO)

Note: RoHS compliant 36210-0100FD is partly packed.

## ● Recommended connectors

The following recommended connectors have been changed to RoHS compliant. Contact the manufacturers for more details.

Connectors	Non-RoHS compliant product	RoHS compliant product	Manufacture	
Amplifier power supply connector (for CNP1, CNP2, CNP3)	56125-0118 (terminal)	56125-0128 (terminal)	Molex	
Servo motor power supply connector	Plug	JN4FT04SJ1	Japan Aviation Electronics Industry	
	Plug (straight)	CE05-6A18-10SD-B-BSS	CE05-6A18-10SD-D-BSS	DDK
		CE05-6A22-22SD-B-BSS	CE05-6A22-22SD-D-BSS	
		CE05-6A22-23SD-B-BSS	CE05-6A22-23SD-D-BSS	
		CE05-6A32-17SD-B-BSS	CE05-6A32-17SD-D-BSS	
		CE05-6A24-10SD-B-BSS	CE05-6A24-10SD-D-BSS	
		MS3106B18-10S	D/MS3106B18-10S	
		MS3106B22-22S	D/MS3106B22-22S	
		MS3106B22-23S	D/MS3106B22-23S	
		MS3106B24-10S	D/MS3106B24-10S	
		MS3106B32-17S	D/MS3106B32-17S	
	Plug (angled)	CE05-8A18-10SD-B-BAS	CE05-8A18-10SD-D-BAS	
		CE05-8A22-22SD-B-BAS	CE05-8A22-22SD-D-BAS	
		CE05-8A32-17SD-B-BAS	CE05-8A32-17SD-D-BAS	
		CE05-8A22-23SD-B-BAS	CE05-8A22-23SD-D-BAS	
		CE05-8A24-10SD-B-BAS	CE05-8A24-10SD-D-BAS	
		MS3108B18-10S	D/MS3108B18-10S	
		MS3108B22-22S	D/MS3108B22-22S	
		MS3108B22-23S	D/MS3108B22-23S	
		MS3108B24-10S	D/MS3108B24-10S	
		MS3108B32-17S	D/MS3108B32-17S	
	Cable clamp	CE3057-10A-1(D265)	CE3057-10A-1-D	
		CE3057-10A-2(D265)	CE3057-10A-2-D	
		CE3057-12A-1(D265)	CE3057-12A-1-D	
		CE3057-12A-2(D265)	CE3057-12A-2-D	
		CE3057-16A-1(D265)	CE3057-16A-1-D	
		CE3057-16A-2(D265)	CE3057-16A-2-D	
MS3057-10A		D/MS3057-10A		
MS3057-12A		D/MS3057-12A		
MS3057-16A		D/MS3057-16A		
MS3057-20A		D/MS3057-20A		
CE3057-20A-1(D265)		CE3057-20A-1-D		
MS3106A10SL-4S		D/MS3106A10SL-4S		
MS3106A10SL-4S(D190)		D/MS3106A10SL-4S(D190)		
JN4FT02SJ1		JN4FT02SJ1-R	Japan Aviation Electronics Industry	
Cable clamp		MS3057-4A	D/MS3057-4A	DDK

# Options

## ● Optional regeneration unit (200VAC)

The power values in the table are resistor-generated powers, not rated powers.

Applicable servo amplifier/drive unit model (MR-J3-)	Built-in regenerative resistor/tolerable regenerative power (W)	Standard accessory (external regenerative resistor)/tolerable regenerative power (W)		Optional regeneration unit/tolerable regeneration power (W)													
		GRZG400-			MR-RB												
		1.5Ω × 4 (Note 2)	0.9Ω × 5 (Note 2)	0.6Ω × 5 (Note 2)	032 [40Ω]	12 [40Ω]	30 [13Ω]	31 [6.7Ω]	32 [40Ω]	50 [13Ω] (Note 1)	51 [6.7Ω] (Note 1)	5E [6Ω] (Note 2)	9P [4.5Ω] (Note 2)	9F [3Ω] (Note 2)	139 [1.3Ω]	137 [1.3Ω] (Note 3)	
10A(1)/B(1)/T(1)	-	-	-	-	30	-	-	-	-	-	-	-	-	-	-	-	-
20A(1)/B(1)/T(1)	10	-	-	-	30	100	-	-	-	-	-	-	-	-	-	-	-
40A(1)/B(1)/T(1)	10	-	-	-	30	100	-	-	-	-	-	-	-	-	-	-	-
60A/B/T	10	-	-	-	30	100	-	-	-	-	-	-	-	-	-	-	-
70A/B/T	20	-	-	-	30	100	-	-	300	-	-	-	-	-	-	-	-
100A/B/T	20	-	-	-	30	100	-	-	300	-	-	-	-	-	-	-	-
200A/B/T	100	-	-	-	-	-	300	-	-	500	-	-	-	-	-	-	-
350A/B/T	100	-	-	-	-	-	300	-	-	500	-	-	-	-	-	-	-
500A/B/T	130	-	-	-	-	-	-	300	-	-	500	-	-	-	-	-	-
700A/B/T	170	-	-	-	-	-	-	300	-	-	500	-	-	-	-	-	-
11KA/B/T	-	500 (800)	-	-	-	-	-	-	-	-	-	500 (800)	-	-	-	-	-
15KA/B/T	-	-	850 (1300)	-	-	-	-	-	-	-	-	-	850 (1300)	-	-	-	-
22KA/B/T	-	-	-	850 (1300)	-	-	-	-	-	-	-	-	-	850 (1300)	-	-	-
DU30KA/B	-	-	-	-	-	-	-	-	-	-	-	-	-	-	1300	3900	-
DU37KA/B	-	-	-	-	-	-	-	-	-	-	-	-	-	-	1300	3900	-

- Notes: 1. Be sure to install a cooling fan. The cooling fan must be prepared by user.  
 2. The values in ( ) indicate when cooling fans (2 units of 92 × 92mm, minimum air flow: 1.0m<sup>3</sup>/min) are installed, and the parameter No. PA02 is changed.  
 3. For MR-RB137, the value applies when 3 units of the regeneration units are used.

## ● Optional regeneration unit (400VAC)

The power values in the table are resistor-generated powers, not rated powers.

Applicable servo amplifier/drive unit model (MR-J3-)	Built-in regenerative resistor/tolerable regenerative power (W)	Standard accessory (external regenerative resistor)/tolerable regenerative power (W)		Optional regeneration unit/tolerable regeneration power (W)													
		GRZG400-			MR-RB												
		5Ω × 4 (Note 2)	2.5Ω × 5 (Note 2)	2Ω × 5 (Note 2)	1H-4 [82Ω]	3M-4 [120Ω] (Note 1)	3G-4 [47Ω] (Note 1)	34-4 [26Ω] (Note 1)	5G-4 [47Ω] (Note 1)	54-4 [26Ω] (Note 1)	6B-4 [20Ω] (Note 2)	60-4 [12.5Ω] (Note 2)	6K-4 [10Ω] (Note 2)	136-4 [5Ω] (Note 3)	138-4 [5Ω] (Note 3)		
60A4/B4/T4	15	-	-	-	100	300	-	-	-	-	-	-	-	-	-	-	-
100A4/B4/T4	15	-	-	-	100	300	-	-	-	-	-	-	-	-	-	-	-
200A4/B4/T4	100	-	-	-	-	-	300	-	500	-	-	-	-	-	-	-	-
350A4/B4/T4	100	-	-	-	-	-	300	-	500	-	-	-	-	-	-	-	-
500A4/B4/T4	130 (Note 4)	-	-	-	-	-	-	300	-	500	-	-	-	-	-	-	-
700A4/B4/T4	170 (Note 4)	-	-	-	-	-	-	300	-	500	-	-	-	-	-	-	-
11KA4/B4/T4	-	500 (800)	-	-	-	-	-	-	-	-	500 (800)	-	-	-	-	-	-
15KA4/B4/T4	-	-	850 (1300)	-	-	-	-	-	-	-	-	850 (1300)	-	-	-	-	-
22KA4/B4/T4	-	-	-	850 (1300)	-	-	-	-	-	-	-	-	850 (1300)	-	-	-	-
DU30KA4/B4	-	-	-	-	-	-	-	-	-	-	-	-	-	-	1300	3900	-
DU37KA4/B4	-	-	-	-	-	-	-	-	-	-	-	-	-	-	1300	3900	-
DU45KA4/B4	-	-	-	-	-	-	-	-	-	-	-	-	-	-	1300	3900	-
DU55KA4/B4	-	-	-	-	-	-	-	-	-	-	-	-	-	-	1300	3900	-

- Notes: 1. Be sure to install a cooling fan. The cooling fan must be prepared by user.  
 2. The values in ( ) indicate when cooling fans (2 units of 92 × 92mm, minimum air flow: 1.0m<sup>3</sup>/min) are installed, and the parameter No. PA02 is changed.  
 3. For MR-RB138-4, the value applies when 3 units of the regeneration units are used.  
 4. The amplifier built-in resistor is compatible with the maximum torque deceleration when the motor is used within the rated speed and the recommended load/motor inertia moment ratio. Contact Mitsubishi if the operating motor speed and the load/motor inertia moment ratio exceed the rated speed and the recommended ratio.

### \*Cautions when connecting the optional regeneration unit.

- The optional regeneration unit will heat up to approx. 100°C, so do not directly mount it on a wall susceptible to heat. Use nonflammable wires or provide flame resistant treatment (use silicon tubes, etc.) on the wires so that the wires do not contact the optional regeneration unit.
- Always use twisted wires for the external regenerative resistor or for the optional regeneration unit, and keep the wire length as short as possible (5m maximum).
- Always use twisted wires for a thermal sensor, and make sure that the sensor does not fail to work properly due to induced noise.

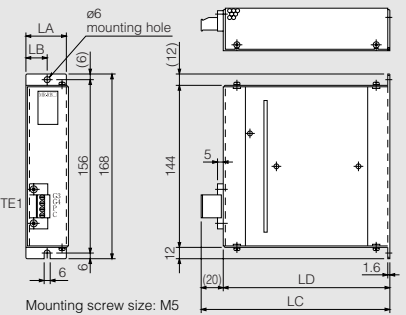
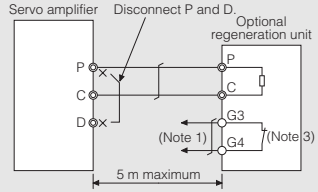
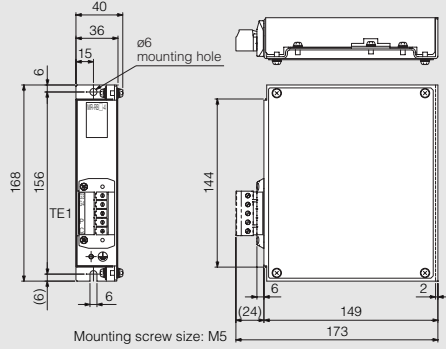
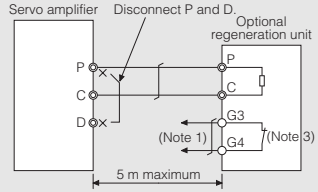
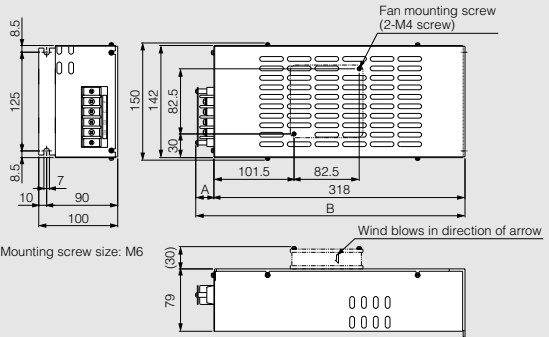
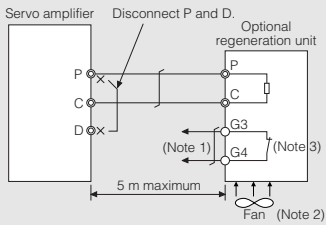
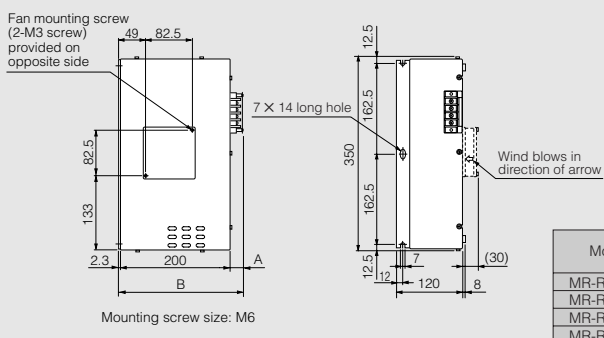
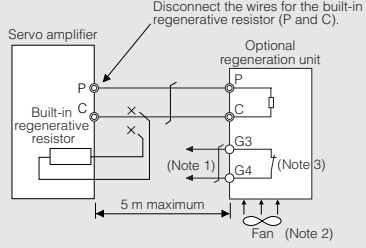
External dimensions (Unit: mm)	Connections																																
<p>● <b>MR-RB032, MR-RB12 (200VAC)</b></p>  <p>&lt;Terminal arrangement&gt;</p> <table border="1" data-bbox="845 403 893 515"> <tr><td>TE1</td></tr> <tr><td>G3</td></tr> <tr><td>G4</td></tr> <tr><td>P</td></tr> <tr><td>C</td></tr> </table> <p>Terminal screw size: M3</p> <table border="1" data-bbox="678 560 989 672"> <thead> <tr> <th>Model</th> <th colspan="4">Variable dimensions</th> <th>Mass</th> </tr> <tr> <th></th> <th>LA</th> <th>LB</th> <th>LC</th> <th>LD</th> <th>kg (lb)</th> </tr> </thead> <tbody> <tr> <td>MR-RB032</td> <td>30</td> <td>15</td> <td>119</td> <td>99</td> <td>0.5 (1.1)</td> </tr> <tr> <td>MR-RB12</td> <td>40</td> <td>15</td> <td>169</td> <td>149</td> <td>1.1 (2.4)</td> </tr> </tbody> </table>	TE1	G3	G4	P	C	Model	Variable dimensions				Mass		LA	LB	LC	LD	kg (lb)	MR-RB032	30	15	119	99	0.5 (1.1)	MR-RB12	40	15	169	149	1.1 (2.4)	<p>Servo amplifier    Disconnect P and D.    Optional regeneration unit</p>  <p>5 m maximum</p>			
TE1																																	
G3																																	
G4																																	
P																																	
C																																	
Model	Variable dimensions				Mass																												
	LA	LB	LC	LD	kg (lb)																												
MR-RB032	30	15	119	99	0.5 (1.1)																												
MR-RB12	40	15	169	149	1.1 (2.4)																												
<p>● <b>MR-RB1H-4 (400VAC)</b></p>  <p>&lt;Terminal arrangement&gt;</p> <table border="1" data-bbox="845 817 893 952"> <tr><td>TE1</td></tr> <tr><td>G3</td></tr> <tr><td>G4</td></tr> <tr><td>P</td></tr> <tr><td>C</td></tr> </table> <table border="1" data-bbox="750 996 981 1086"> <thead> <tr> <th>Model</th> <th>Mass</th> </tr> <tr> <th></th> <th>kg (lb)</th> </tr> </thead> <tbody> <tr> <td>MR-RB1H-4</td> <td>1.1 (2.4)</td> </tr> </tbody> </table>	TE1	G3	G4	P	C	Model	Mass		kg (lb)	MR-RB1H-4	1.1 (2.4)	<p>Servo amplifier    Disconnect P and D.    Optional regeneration unit</p>  <p>5 m maximum</p>																					
TE1																																	
G3																																	
G4																																	
P																																	
C																																	
Model	Mass																																
	kg (lb)																																
MR-RB1H-4	1.1 (2.4)																																
<p>● <b>MR-RB30, MR-RB31, MR-RB32 (200VAC)</b> ● <b>MR-RB3M-4, MR-RB3G-4, MR-RB34-4 (400VAC)</b></p>  <p>&lt;Terminal arrangement&gt;</p> <table border="1" data-bbox="829 1220 877 1321"> <tr><td>P</td></tr> <tr><td>C</td></tr> <tr><td>G3</td></tr> <tr><td>G4</td></tr> </table> <p>Terminal screw size: M4</p> <table border="1" data-bbox="686 1344 1013 1500"> <thead> <tr> <th rowspan="2">Model</th> <th colspan="2">Variable dimensions</th> <th rowspan="2">Mass</th> </tr> <tr> <th>A</th> <th>B</th> <th>kg (lb)</th> </tr> </thead> <tbody> <tr> <td>MR-RB30</td> <td></td> <td></td> <td rowspan="3">2.9 (6.4)</td> </tr> <tr> <td>MR-RB31</td> <td>17</td> <td>335</td> </tr> <tr> <td>MR-RB32</td> <td></td> <td></td> </tr> <tr> <td>MR-RB3M-4</td> <td>23</td> <td>341</td> <td rowspan="2">2.9 (6.4)</td> </tr> <tr> <td>MR-RB3G-4</td> <td></td> <td></td> </tr> <tr> <td>MR-RB34-4</td> <td></td> <td></td> <td></td> </tr> </tbody> </table>	P	C	G3	G4	Model	Variable dimensions		Mass	A	B	kg (lb)	MR-RB30			2.9 (6.4)	MR-RB31	17	335	MR-RB32			MR-RB3M-4	23	341	2.9 (6.4)	MR-RB3G-4			MR-RB34-4				<p>● <b>MR-J3-350□ or smaller</b> ● <b>MR-J3-200□4 or smaller</b></p> <p>Servo amplifier    Disconnect P and D.    Optional regeneration unit</p>  <p>5 m maximum</p> <p>Fan (Note 2)</p>
P																																	
C																																	
G3																																	
G4																																	
Model	Variable dimensions		Mass																														
	A	B		kg (lb)																													
MR-RB30			2.9 (6.4)																														
MR-RB31	17	335																															
MR-RB32																																	
MR-RB3M-4	23	341	2.9 (6.4)																														
MR-RB3G-4																																	
MR-RB34-4																																	
<p>● <b>MR-RB50, MR-RB51 (200VAC)</b> ● <b>MR-RB5G-4, MR-RB54-4 (400VAC)</b></p>  <p>&lt;Terminal arrangement&gt;</p> <table border="1" data-bbox="829 1668 877 1769"> <tr><td>P</td></tr> <tr><td>C</td></tr> <tr><td>G3</td></tr> <tr><td>G4</td></tr> </table> <p>Terminal screw size: M4</p> <table border="1" data-bbox="686 1803 1013 1926"> <thead> <tr> <th rowspan="2">Model</th> <th colspan="2">Variable dimensions</th> <th rowspan="2">Mass</th> </tr> <tr> <th>A</th> <th>B</th> <th>kg (lb)</th> </tr> </thead> <tbody> <tr> <td>MR-RB50</td> <td>17</td> <td>217</td> <td rowspan="4">5.6 (12)</td> </tr> <tr> <td>MR-RB51</td> <td></td> <td></td> </tr> <tr> <td>MR-RB5G-4</td> <td>23</td> <td>223</td> </tr> <tr> <td>MR-RB54-4</td> <td></td> <td></td> </tr> </tbody> </table>	P	C	G3	G4	Model	Variable dimensions		Mass	A	B	kg (lb)	MR-RB50	17	217	5.6 (12)	MR-RB51			MR-RB5G-4	23	223	MR-RB54-4			<p>● <b>MR-J3-500□, 700□</b> ● <b>MR-J3-350□4 to 700□4</b></p> <p>Servo amplifier    Disconnect the wires for the built-in regenerative resistor (P and C).    Optional regeneration unit</p>  <p>5 m maximum</p> <p>Fan (Note 2)</p>								
P																																	
C																																	
G3																																	
G4																																	
Model	Variable dimensions		Mass																														
	A	B		kg (lb)																													
MR-RB50	17	217	5.6 (12)																														
MR-RB51																																	
MR-RB5G-4	23	223																															
MR-RB54-4																																	

- Notes: 1. Create a sequence that turns off the magnetic contactor (MC) when abnormal overheating occurs.  
 2. When using MR-RB3M-4, MR-RB3G-4, MR-RB34-4, MR-RB50, MR-RB51, MR-RB5G-4 or MR-RB54-4, cool the unit forcibly with a fan (92 X 92mm, minimum air flow: 1.0m<sup>3</sup>/min). The cooling fan must be prepared by user.  
 3. The G3 and G4 terminals are thermal sensor. G3-G4 opens when the regenerative unit overheats abnormally.

## ● Optional regeneration unit

External dimensions	Connections																																																								
<p>(Unit: mm)</p> <p>● GRZG400-1.5Ω, GRZG400-0.9Ω, GRZG400-0.6Ω (200VAC): Standard accessory (Note 1, 2)            ● GRZG400-5Ω, GRZG400-2.5Ω, GRZG400-2Ω (400VAC): Standard accessory (Note 1, 2)</p> <p>Mounting screw size: M8</p> <table border="1" style="width: 100%; border-collapse: collapse; text-align: center;"> <thead> <tr> <th>Model</th> <th>Qty.</th> <th>Tolerable regenerative power (W)</th> <th>With fan (W)</th> <th>Resistance value (Ω)</th> <th colspan="3">Variable dimensions</th> <th>Mass/unit</th> </tr> <tr> <th></th> <th></th> <th></th> <th></th> <th></th> <th>A</th> <th>C</th> <th>K</th> <th></th> </tr> </thead> <tbody> <tr> <td>GRZG400-1.5Ω</td> <td>4</td> <td>500</td> <td>800</td> <td>6 (1.5Ω × 4)</td> <td>10</td> <td>5.5</td> <td>39</td> <td rowspan="5">0.8 (1.8)</td> </tr> <tr> <td>GRZG400-0.9Ω</td> <td rowspan="2">5</td> <td>850</td> <td>1300</td> <td>4.5 (0.9Ω × 5)</td> <td rowspan="2">16</td> <td rowspan="2">8.2</td> <td rowspan="2">46</td> </tr> <tr> <td>GRZG400-0.6Ω</td> <td>850</td> <td>1300</td> <td>3 (0.6Ω × 5)</td> </tr> <tr> <td>GRZG400-5Ω</td> <td>4</td> <td>500</td> <td>800</td> <td>20 (5Ω × 4)</td> <td rowspan="2">10</td> <td rowspan="2">5.5</td> <td rowspan="2">39</td> </tr> <tr> <td>GRZG400-2.5Ω</td> <td rowspan="2">5</td> <td>850</td> <td>1300</td> <td>12.5 (2.5Ω × 5)</td> </tr> <tr> <td>GRZG400-2Ω</td> <td>850</td> <td>1300</td> <td>10 (2Ω × 5)</td> </tr> </tbody> </table>	Model	Qty.	Tolerable regenerative power (W)	With fan (W)	Resistance value (Ω)	Variable dimensions			Mass/unit						A	C	K		GRZG400-1.5Ω	4	500	800	6 (1.5Ω × 4)	10	5.5	39	0.8 (1.8)	GRZG400-0.9Ω	5	850	1300	4.5 (0.9Ω × 5)	16	8.2	46	GRZG400-0.6Ω	850	1300	3 (0.6Ω × 5)	GRZG400-5Ω	4	500	800	20 (5Ω × 4)	10	5.5	39	GRZG400-2.5Ω	5	850	1300	12.5 (2.5Ω × 5)	GRZG400-2Ω	850	1300	10 (2Ω × 5)	<p>5 m maximum Do not disconnect the short bar.</p> <p>Servo amplifier MR-J3-11K□(4) to 22K□(4)</p> <p>Serial connection (Note 3)</p> <p>Fan (2 units of 92 X 92mm<sup>3</sup>, minimum air flow: 1.0m<sup>3</sup>/min)</p> <p>Leave a space of 70mm or more between each resistor.</p>
Model	Qty.	Tolerable regenerative power (W)	With fan (W)	Resistance value (Ω)	Variable dimensions			Mass/unit																																																	
					A	C	K																																																		
GRZG400-1.5Ω	4	500	800	6 (1.5Ω × 4)	10	5.5	39	0.8 (1.8)																																																	
GRZG400-0.9Ω	5	850	1300	4.5 (0.9Ω × 5)	16	8.2	46																																																		
GRZG400-0.6Ω		850	1300	3 (0.6Ω × 5)																																																					
GRZG400-5Ω	4	500	800	20 (5Ω × 4)	10	5.5	39																																																		
GRZG400-2.5Ω	5	850	1300	12.5 (2.5Ω × 5)																																																					
GRZG400-2Ω		850	1300	10 (2Ω × 5)																																																					

<p>● MR-RB5E, MR-RB9P, MR-RB9F (200VAC) (Note 2)            ● MR-RB6B-4, MR-RB60-4, MR-RB6K-4 (400VAC) (Note 2)</p> <p>2-φ10 mounting hole</p> <p>TE1</p> <p>4-M3 screw for fan mounting</p> <p>Mounting screw size: M8</p> <p>&lt;Terminal arrangement&gt;            TE1 G4 G3 C P            Terminal screw size: M5</p>	<p>5 m maximum Do not disconnect the short bar.</p> <p>Servo amplifier MR-J3-11K□(4) to 22K□(4)</p> <p>Optional regeneration unit</p> <p>(Note 4)</p> <p>Create a circuit that shuts off the main circuit power supply when the thermal sensor activates.</p>																																	
<table border="1" style="width: 100%; border-collapse: collapse; text-align: center;"> <thead> <tr> <th>Model</th> <th>Tolerable regenerative power (W)</th> <th>With fan (W)</th> <th>Description</th> <th>Mass kg (lb)</th> </tr> </thead> <tbody> <tr> <td>MR-RB5E</td> <td>500</td> <td>800</td> <td>GRZG400-1.5Ω × 4</td> <td>10 (22)</td> </tr> <tr> <td>MR-RB9P</td> <td>850</td> <td>1300</td> <td>GRZG400-0.9Ω × 5</td> <td rowspan="2">11 (24)</td> </tr> <tr> <td>MR-RB9F</td> <td>850</td> <td>1300</td> <td>GRZG400-0.6Ω × 5</td> </tr> <tr> <td>MR-RB6B-4</td> <td>500</td> <td>800</td> <td>GRZG400-5Ω × 4</td> <td>10 (22)</td> </tr> <tr> <td>MR-RB60-4</td> <td>850</td> <td>1300</td> <td>GRZG400-2.5Ω × 5</td> <td rowspan="2">11 (24)</td> </tr> <tr> <td>MR-RB6K-4</td> <td>850</td> <td>1300</td> <td>GRZG400-2Ω × 5</td> </tr> </tbody> </table>	Model	Tolerable regenerative power (W)	With fan (W)	Description	Mass kg (lb)	MR-RB5E	500	800	GRZG400-1.5Ω × 4	10 (22)	MR-RB9P	850	1300	GRZG400-0.9Ω × 5	11 (24)	MR-RB9F	850	1300	GRZG400-0.6Ω × 5	MR-RB6B-4	500	800	GRZG400-5Ω × 4	10 (22)	MR-RB60-4	850	1300	GRZG400-2.5Ω × 5	11 (24)	MR-RB6K-4	850	1300	GRZG400-2Ω × 5	
Model	Tolerable regenerative power (W)	With fan (W)	Description	Mass kg (lb)																														
MR-RB5E	500	800	GRZG400-1.5Ω × 4	10 (22)																														
MR-RB9P	850	1300	GRZG400-0.9Ω × 5	11 (24)																														
MR-RB9F	850	1300	GRZG400-0.6Ω × 5																															
MR-RB6B-4	500	800	GRZG400-5Ω × 4	10 (22)																														
MR-RB60-4	850	1300	GRZG400-2.5Ω × 5	11 (24)																														
MR-RB6K-4	850	1300	GRZG400-2Ω × 5																															

Notes: 1. Servo amplifiers (MR-J3-11K□(4)-PX to MR-J3-22K□(4)-PX) without an enclosed regenerative resistor are available for the servo amplifiers MR-J3-11K□(4) to MR-J3-22K□(4).  
 2. To increase the regeneration braking frequency, install cooling fans (2 units of 92 × 92mm, minimum air flow: 1.0m<sup>3</sup>/min) and change the parameter No. PA02. The cooling fans must be prepared by user.  
 3. By installing a thermal sensor, create a safety circuit that shuts off the main circuit power supply when abnormal overheating occurs.  
 4. The G3 and G4 terminals are thermal sensor. G3-G4 opens when the regenerative unit overheats abnormally.

## ● Optional regeneration unit

External dimensions (Unit: mm)	Connections															
<p>● MR-RB139, MR-RB137 (200VAC) ● MR-RB136-4, MR-RB138-4 (400VAC)</p> <p style="text-align: center;">&lt;Terminal arrangement (200VAC)&gt; TE1 R S G4 G3 C P Terminal screw size: M5</p> <p style="text-align: center;">&lt;Terminal arrangement (400VAC)&gt; TE1 R400 S400 G4 G3 C P Terminal screw size: M5</p> <p style="text-align: center;">Mounting screw size: M8</p> <table border="1" style="width: 100%; border-collapse: collapse; margin-top: 20px;"> <thead> <tr> <th>Model</th> <th>Tolerable regenerative power (W)</th> <th>Mass kg (lb)</th> </tr> </thead> <tbody> <tr> <td>MR-RB139</td> <td>1300</td> <td>10 (22)</td> </tr> <tr> <td>MR-RB137</td> <td>3900 (3 units are required.) (Note 2)</td> <td>11 (24)</td> </tr> <tr> <td>MR-RB136-4</td> <td>1300</td> <td>10 (22)</td> </tr> <tr> <td>MR-RB138-4</td> <td>3900 (3 units are required.) (Note 2)</td> <td>11 (24)</td> </tr> </tbody> </table>	Model	Tolerable regenerative power (W)	Mass kg (lb)	MR-RB139	1300	10 (22)	MR-RB137	3900 (3 units are required.) (Note 2)	11 (24)	MR-RB136-4	1300	10 (22)	MR-RB138-4	3900 (3 units are required.) (Note 2)	11 (24)	<p>● MR-RB139 ● MR-RB136-4</p> <p>*Create an external sequence that turns off the main circuit contactor of the converter unit when the normally closed thermal sensor contact in the optional regeneration unit opens due to overheating.</p> <p>● MR-RB137 ● MR-RB138-4</p> <p>*Create an external sequence that turns off the main circuit contactor of the converter unit when the normally closed thermal sensor contact in the optional regeneration unit opens due to overheating.</p>
Model	Tolerable regenerative power (W)	Mass kg (lb)														
MR-RB139	1300	10 (22)														
MR-RB137	3900 (3 units are required.) (Note 2)	11 (24)														
MR-RB136-4	1300	10 (22)														
MR-RB138-4	3900 (3 units are required.) (Note 2)	11 (24)														

Notes: 1. One unit of cooling fan is attached for MR-RB139 or MR-RB137.

2. Three units of MR-RB137 or MR-RB138-4 are required per converter unit.

3. Connect the optional regenerative unit to the converter unit. The cable length between the regenerative unit and converter unit must be 5m or shorter.

4. When using the DC reactor, disconnect the short bar between P1 and P2.

# Options

## ● Battery (MR-J3BAT)

The servo motor's absolute value can be maintained by mounting the battery on the servo amplifier. The battery is not required when the servo system is used in incremental mode.

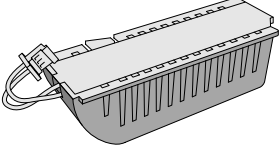
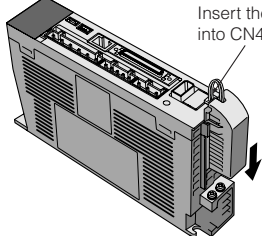
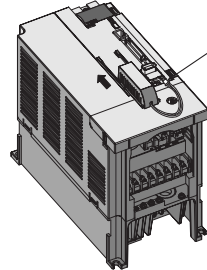
Appearance	Installation method
 <p>Model: MR-J3BAT Nominal voltage: 3.6V Nominal capacity: 2000mAh Lithium content: 0.65g</p>	<div style="display: flex; justify-content: space-around;"> <div style="text-align: center;"> <p>● MR-J3-350□ or smaller ● MR-J3-200□4 or smaller</p>  <p>Insert the connector into CN4.</p> </div> <div style="text-align: center;"> <p>● MR-J3-500□ or larger ● MR-J3-350□4 or larger</p>  <p>Insert the connector into CN4.</p> </div> </div>

Note: The 44th Edition of the IATA (International Air Transportation Association) Dangerous Goods Regulations was taken effect on January 1st, 2003 and administered immediately. In this edition, the provisions relating to lithium and lithium ion batteries have been revised to strengthen regulations on the air transportation of batteries. This battery is not classified as dangerous goods (not class 9). Therefore, transporting 24 units or less is not subject to the regulations. However, a packing based on Packing Instruction 903 is required for transporting 25 units or more. For the self-certification form for the battery safety test or more information, contact Mitsubishi. (as of July, 2007)

## ● Battery connection relay cable (MR-J3BTCBL03M)

Use this relay cable to hold the absolute value if the servo amplifier has to be removed from a machine for shipping. The servo motor does not have a super capacitor (for holding an absolute value for short time) in the encoder. When this optional cable is used, the absolute value can be held even when the encoder cable is disconnected from the servo amplifier, making it easy to do maintenance on the servo amplifier.

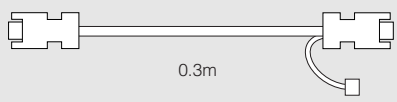
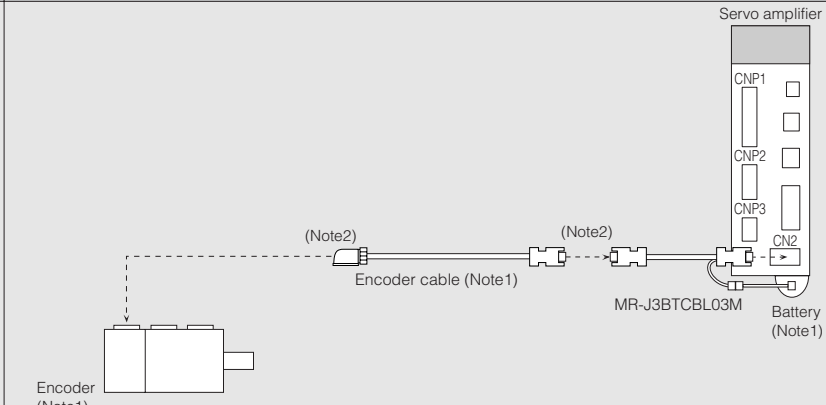
Appearance	Installation method
 <p>0.3m</p>	

Notes: 1. The encoder cable varies depending on the motor series. Refer to the section "Options ● Cables and connectors" in this catalog.  
2. To hold the absolute value, the encoder, the encoder cable (s), the relay cable and the battery must be kept connected.

User's system		Battery (MR-J3BAT)	Battery connection relay cable (MR-J3BTCBL03M)
Incremental	—	Not required	Not required
Absolute	Not necessary to hold an absolute value after the encoder cable is disconnected from the servo amplifier	Required	Not required
	Necessary to hold an absolute value after the encoder cable is disconnected from the servo amplifier (Note)	Required	Required

Note: Start up the absolute system after connecting this optional cable.

## ● Diagnostic cable (MR-J3ACHECK): For MR-J3-□A□ and MR-J3-DU□A(4)

This cable is required when using the amplifier diagnostic function of MR Configurator (Setup software).

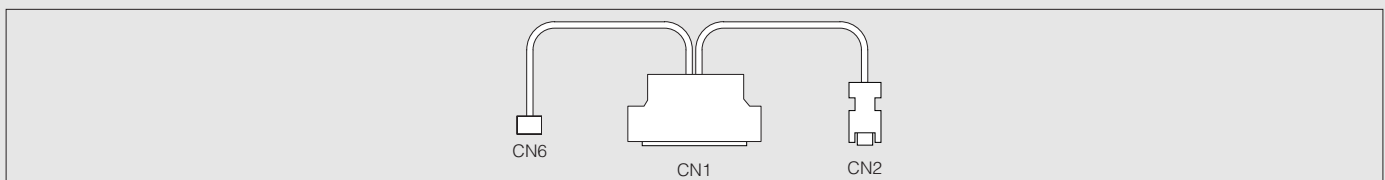

### ● Parameter unit MR-PRU03

The parameter unit with a 16 characters × 4 lines display, is available as an option.

By connecting the parameter unit to the servo amplifier, data setting, test operation, parameter setting, etc. can be performed without using MR Configurator.

The parameter unit can be used with MR-J3-□A□, MR-J3-DU□A(4) or MR-J3-□T□.

#### <Wiring and communication method>

- RS-422 communication
- Connectable with one unit of the servo amplifier with the commercial LAN cable
- Connectable up to 32 axes with multi-drop system

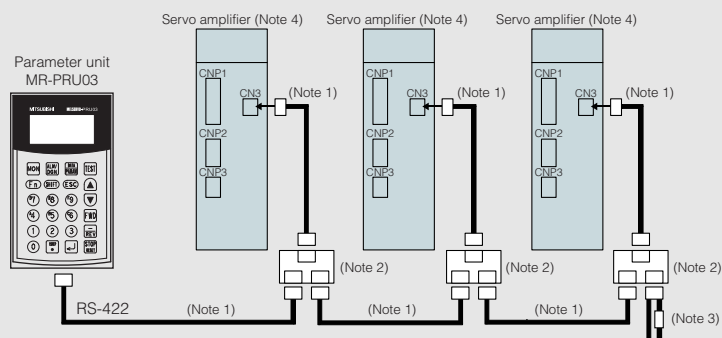

Notes: 1. Use 10BASE-T cable (EIA568 compliant), etc.

Keep the distance between the branch connector and servo amplifier as short as possible.

2. Branch connector: BMJ-8 (HACHIKO ELECTRIC CO., LTD) is recommended.

3. Connect a terminal resistor, 150Ω.

4. The parameter unit can be connected to the servo amplifier, MR-J3-□A□ or MR-J3-□T□, or the drive unit, MR-J3-DU□A (4).

#### <Dimensions>

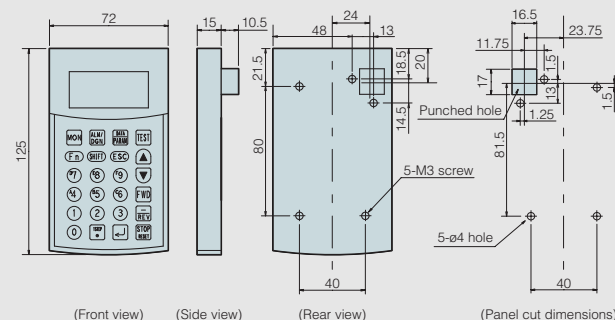

#### <Specifications>

Item	Description		
Model	MR-PRU03		
Power supply	Receives power from the servo amplifier or the drive unit		
Functions	Parameter mode	Basic setting parameters, gain/filter parameters, extension setting parameters, input/output setting parameters	
	Monitor mode	MR-J3-□A□ MR-J3-DU□A(4)	Cumulative feedback pulses, droop pulses, cumulative command pulses, command pulse frequency, analog speed command voltage/analog speed limit voltage, analog torque command voltage/analog torque limit voltage, regenerative load ratio, effective load ratio, peak load ratio, instantaneous torque, within one revolution position, ABS counter, servo motor speed, bus voltage, load inertia moment ratio
		MR-J3-□T□	Current position, command position, command remaining distance, point table No., cumulative feedback pulses, droop pulses, regenerative load ratio, effective load ratio, peak load ratio, instantaneous torque, within one revolution position, ABS counter, servo motor speed, bus voltage, load inertia moment ratio
	Diagnosis mode	External input/output display, motor information	
	Alarm mode	Current alarm, alarm history	
	Test operation mode	JOG operation, positioning operation, DO forced output, motor-less operation, single-step feed (Note)	
	Point table mode (Note)	Position data, servo motor speed, acceleration/deceleration time constant, dwell time, auxiliary function, M code	
Display	LCD system (16 characters × 4 lines)		
Environment	Ambient temperature in operation	-10 to 55°C (14 to 131°F) (non freezing)	
	Ambient humidity in operation	90%RH maximum (non condensing)	
	Storage temperature	-20 to 65°C (-4 to 149°F) (non freezing)	
	Storage humidity	90%RH maximum (non condensing)	
	Atmosphere	Indoors (no direct sunlight); no corrosive gas, inflammable gas, oil mist or dust	
Mass (g [lb])	130 (0.29)		

Note: The point table mode and single-step feed under the test operation mode are available only when connected to MR-J3-□T□.

# Options

## ● Heat sink outside attachment (MR-J3ACN): For MR-J3-11K□(4) to MR-J3-22K□(4)

By mounting the heat sink outside attachment on the servo amplifier, the heat generating section can be mounted outside the control box. This makes it possible to dissipate the unit's heat to outside the box. Approx. 50% of the heating value can be dissipated with this method, and the control box dimensions can be downsized.

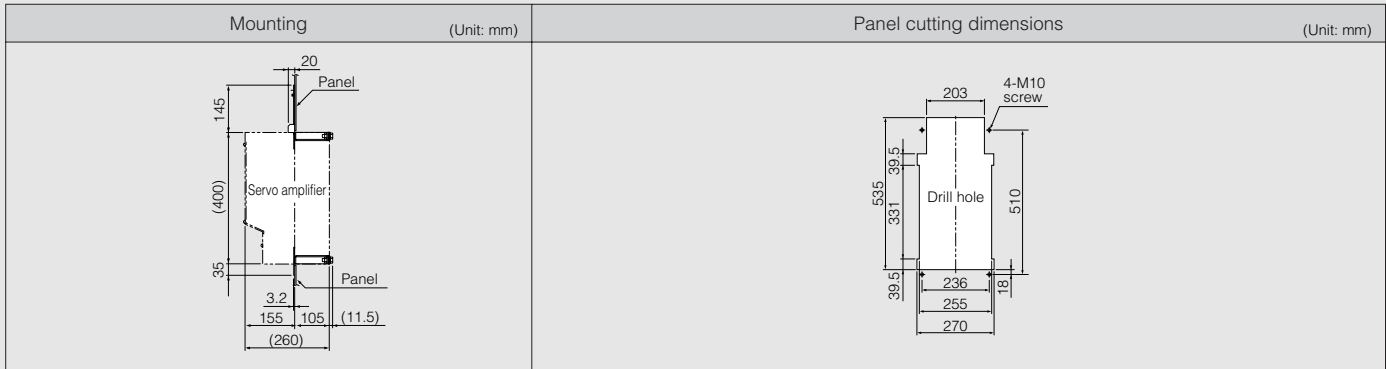

## ● Junction terminal block (MR-TB50): For MR-J3-□A□, MR-J3-DU□A(4) and MR-J3-D01

All signals can be received with this junction terminal block without connecting the signals to CN1.

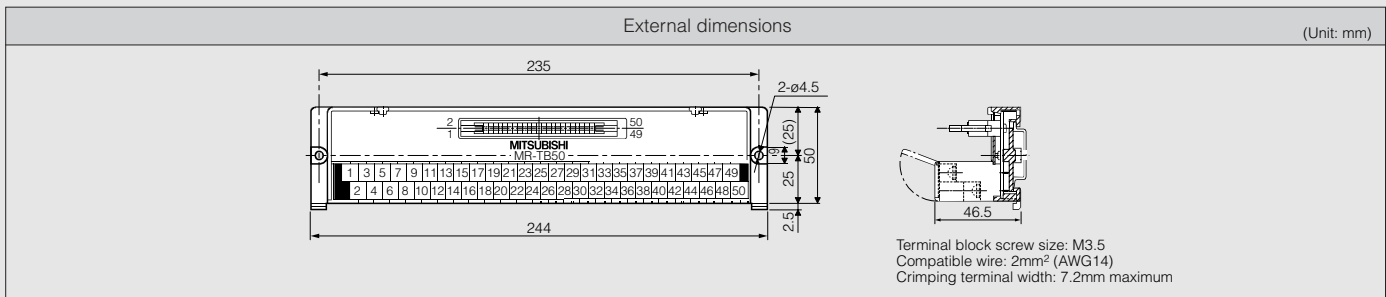

## ● Manual pulse generator (MR-HDP01): For MR-J3-□T□

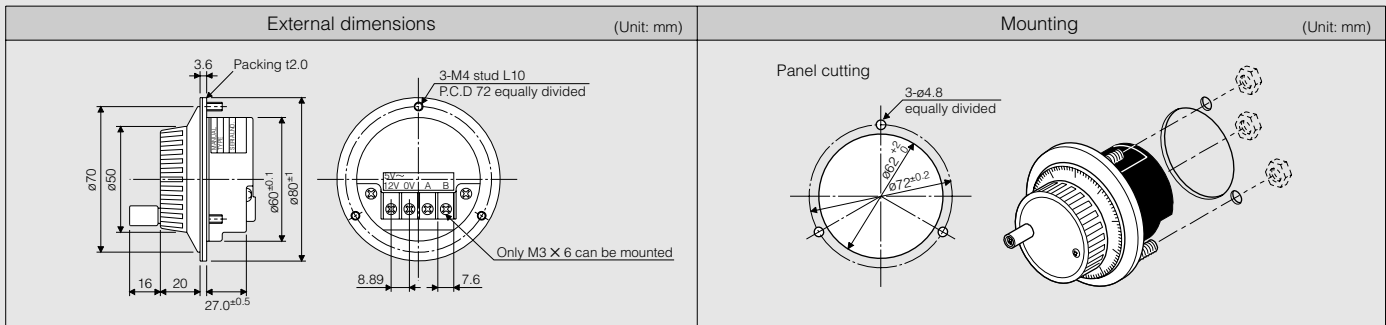

Note: Manufacture a cable for the manual pulse generator using the optional connector set for CN6 (MR-J2CMP2). Refer to "MR-J3-□T SERVO AMPLIFIER INSTRUCTION MANUAL" for details.

## ● Digital switch (MR-DS60): For MR-J3-D01

By using the 6-digit digital switch, position data can be sent to the servo amplifier with BCD signal.

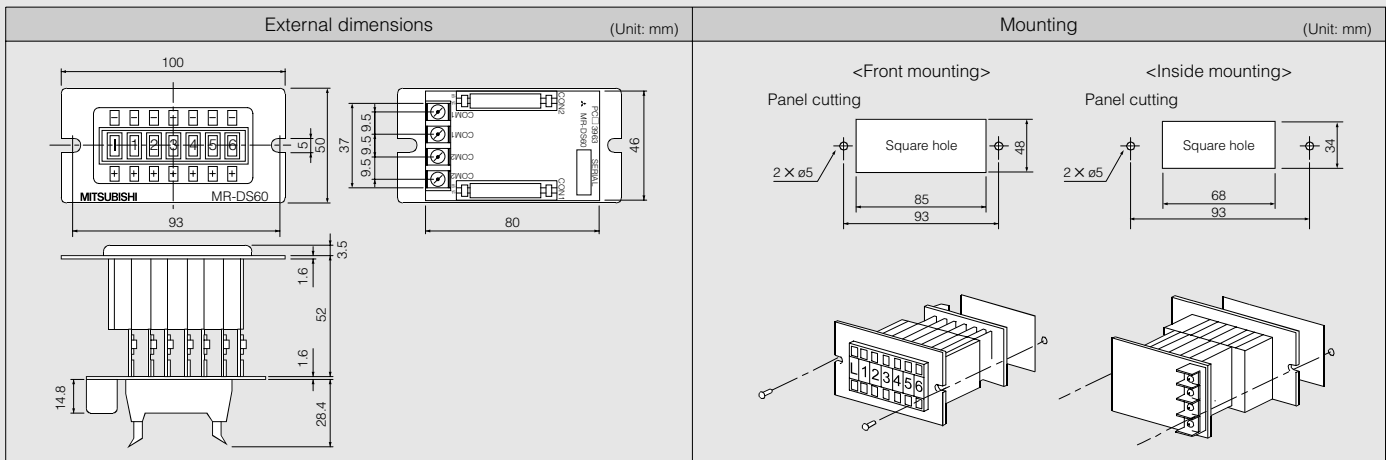



# Peripheral Equipment

## ● Radio noise filter (FR-BIF)

This filter effectively controls noise emitted from the power supply side of the servo amplifier or the converter unit, and is especially effective for radio frequency bands 10MHz or lower. The FR-BIF is designed for the input only.

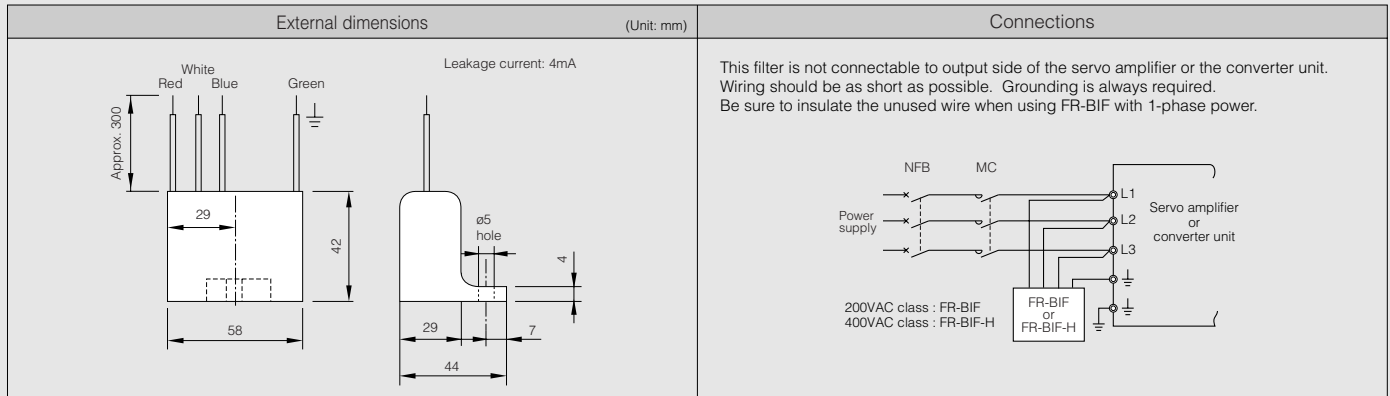

## ● Line noise filter (FR-BSF01, FR-BLF)

This filter is effective in suppressing radio noise emitted from the power supply side or output side of the servo amplifier or the converter unit, and also in suppressing high-frequency leakage current (zero-phase current), especially within 0.5 to 5MHz band.

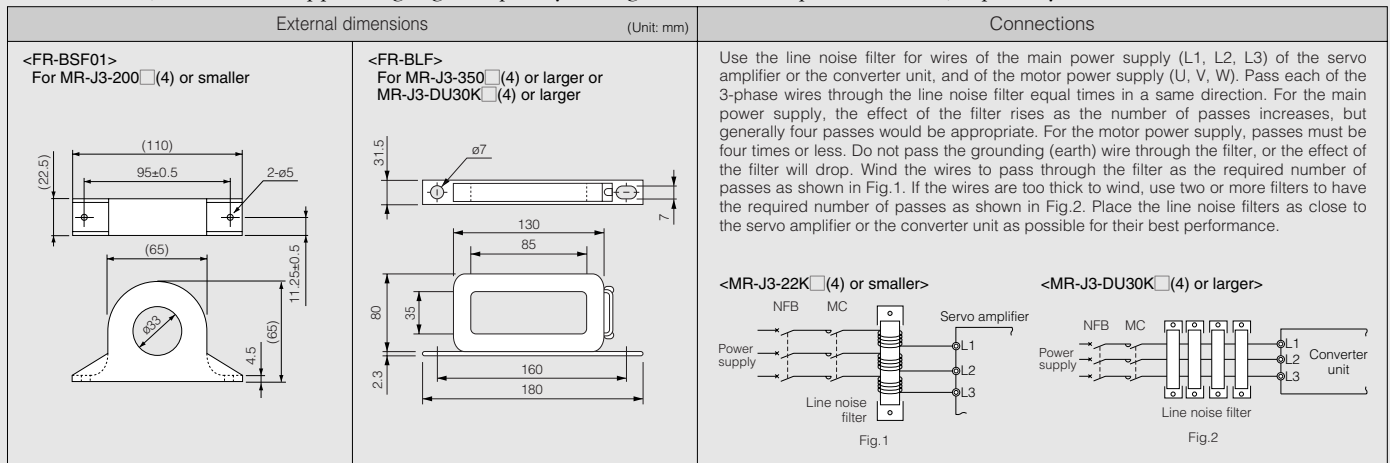

## ● Surge suppressor

Attach surge suppressors to AC relays and AC valves around the servo amplifier or the drive unit and the converter unit. Attach diodes to DC relays and DC valves.

Sample configuration

Surge suppressor: 972A-2003 504 11 (rated 200VAC, manufactured by Matsuo Denki)

Diode : A diode with breakdown voltage 4 or more times greater than the relay's drive voltage, and with current capacity 2 or more times greater than the relay's drive current.

## ● Data line filter

Noise can be prevented by attaching a data line filter to the pulse output cable of the pulse train output controller (QD75D, etc.) or motor encoder cable.

Sample configuration

Data line filter examples: ESD-SR-25 (manufactured by NEC TOKIN) or ZCAT3035-1330 (manufactured by TDK)

# Peripheral Equipment

## ● EMC filter

The following filters are recommended as a filter compliant with the EMC directive for the servo amplifier's power supply. (Note 1)

Model	Applicable servo amplifier or drive unit	Applicable converter unit	Fig.
HF3010A-UN (Note 2)	MR-J3-10A/B/T to 100A/B/T MR-J3-10A1/B1/T1 to 40A1/B1/T1	-	A
HF3030A-UN (Note 2)	MR-J3-200A/B/T MR-J3-350A/B/T	-	B
HF3040A-UN (Note 2)	MR-J3-500A/B/T MR-J3-700A/B/T	-	B
HF3100A-UN (Note 2)	MR-J3-11KA/B/T to 22KA/B/T	-	C
HF3200A-UN (Note 2)	MR-J3-DU30KA/B MR-J3-DU37KA/B	MR-J3-CR55K	D

- Notes: 1. Manufactured by SOSHIN ELECTRIC CO.  
2. A surge protector is separately required to use this EMC filter. Refer to "EMC Installation Guidelines".

Model	Applicable servo amplifier or drive unit	Applicable converter unit	Fig.
TF3005C-TX	MR-J3-60A4/B4/T4 MR-J3-100A4/B4/T4	-	E
TF3020C-TX	MR-J3-200A4/B4/T4 MR-J3-350A4/B4/T4 MR-J3-500A4/B4/T4 MR-J3-700A4/B4/T4	-	
TF3030C-TX	MR-J3-11KA4/B4/T4	-	
TF3040C-TX	MR-J3-15KA4/B4/T4	-	F
TF3060C-TX	MR-J3-22KA4/B4/T4	-	F
TF3150C-TX	MR-J3-DU30KA4/B4 MR-J3-DU37KA4/B4 MR-J3-DU45KA4/B4 MR-J3-DU55KA4/B4	MR-J3-CR55K4	G

	External dimensions (Unit: mm)	Connections									
A	<p>● HF3010A-UN</p> <table border="1"> <thead> <tr> <th>Model</th> <th>Leakage current (mA)</th> <th>Mass (kg (lb))</th> </tr> </thead> <tbody> <tr> <td>HF3010A-UN</td> <td>5</td> <td>3 (6.6)</td> </tr> </tbody> </table>	Model	Leakage current (mA)	Mass (kg (lb))	HF3010A-UN	5	3 (6.6)	<p>Note: When using a power supply, 1-phase 200 to 230VAC, connect the power supply to the L1 and L2 terminals. Do not connect anything to L3. 1-phase 200 to 230VAC is available only for the MR-J3-70 or smaller servo amplifier. There is no L3 for 1-phase 100 to 120VAC power supply.</p>			
Model	Leakage current (mA)	Mass (kg (lb))									
HF3010A-UN	5	3 (6.6)									
B	<p>● HF3030A-UN, HF3040A-UN</p> <table border="1"> <thead> <tr> <th>Model</th> <th>Leakage current (mA)</th> <th>Mass (kg (lb))</th> </tr> </thead> <tbody> <tr> <td>HF3030A-UN</td> <td>5</td> <td>5.5 (12)</td> </tr> <tr> <td>HF3040A-UN</td> <td>1.5</td> <td>6.0 (13)</td> </tr> </tbody> </table>	Model	Leakage current (mA)	Mass (kg (lb))	HF3030A-UN	5	5.5 (12)	HF3040A-UN	1.5	6.0 (13)	<p>Note: When using a power supply, 1-phase 200 to 230VAC, connect the power supply to the L1 and L2 terminals. Do not connect anything to L3. 1-phase 200 to 230VAC is available only for the MR-J3-70 or smaller servo amplifier. There is no L3 for 1-phase 100 to 120VAC power supply.</p>
Model	Leakage current (mA)	Mass (kg (lb))									
HF3030A-UN	5	5.5 (12)									
HF3040A-UN	1.5	6.0 (13)									
C	<p>● HF3100A-UN</p> <table border="1"> <thead> <tr> <th>Model</th> <th>Leakage current (mA)</th> <th>Mass (kg (lb))</th> </tr> </thead> <tbody> <tr> <td>HF3100A-UN</td> <td>6.5</td> <td>15 (33)</td> </tr> </tbody> </table>	Model	Leakage current (mA)	Mass (kg (lb))	HF3100A-UN	6.5	15 (33)	<p>Note: When using a power supply, 1-phase 200 to 230VAC, connect the power supply to the L1 and L2 terminals. Do not connect anything to L3. 1-phase 200 to 230VAC is available only for the MR-J3-70 or smaller servo amplifier. There is no L3 for 1-phase 100 to 120VAC power supply.</p>			
Model	Leakage current (mA)	Mass (kg (lb))									
HF3100A-UN	6.5	15 (33)									

	External dimensions (Unit: mm)	Connections										
D	<p>● <b>TF3200A-UN</b></p> <table border="1"> <thead> <tr> <th>Model</th> <th>Leakage current (mA)</th> <th>Mass kg (lb)</th> </tr> </thead> <tbody> <tr> <td>TF3200A-UN</td> <td>9.0</td> <td>18 (40)</td> </tr> </tbody> </table>	Model	Leakage current (mA)	Mass kg (lb)	TF3200A-UN	9.0	18 (40)					
Model	Leakage current (mA)	Mass kg (lb)										
TF3200A-UN	9.0	18 (40)										
E	<p>● <b>TF3005C-TX, TF3020C-TX, TF3030C-TX</b></p> <table border="1"> <thead> <tr> <th>Model</th> <th>Leakage current (mA)</th> <th>Mass kg (lb)</th> </tr> </thead> <tbody> <tr> <td>TF3005C-TX</td> <td rowspan="3">5.5</td> <td>6.0 (13)</td> </tr> <tr> <td>TF3020C-TX</td> <td>7.5 (17)</td> </tr> <tr> <td>TF3030C-TX</td> <td></td> </tr> </tbody> </table>	Model	Leakage current (mA)	Mass kg (lb)	TF3005C-TX	5.5	6.0 (13)	TF3020C-TX	7.5 (17)	TF3030C-TX		
Model	Leakage current (mA)	Mass kg (lb)										
TF3005C-TX	5.5	6.0 (13)										
TF3020C-TX		7.5 (17)										
TF3030C-TX												
F	<p>● <b>TF3040C-TX, TF3060C-TX</b></p> <table border="1"> <thead> <tr> <th>Model</th> <th>Leakage current (mA)</th> <th>Mass kg (lb)</th> </tr> </thead> <tbody> <tr> <td>TF3040C-TX</td> <td rowspan="2">5.5</td> <td rowspan="2">12.5 (28)</td> </tr> <tr> <td>TF3060C-TX</td> </tr> </tbody> </table>	Model	Leakage current (mA)	Mass kg (lb)	TF3040C-TX	5.5	12.5 (28)	TF3060C-TX				
Model	Leakage current (mA)	Mass kg (lb)										
TF3040C-TX	5.5	12.5 (28)										
TF3060C-TX												
G	<p>● <b>TF3150C-TX</b></p> <table border="1"> <thead> <tr> <th>Model</th> <th>Leakage current (mA)</th> <th>Mass kg (lb)</th> </tr> </thead> <tbody> <tr> <td>TF3150C-TX</td> <td>5.5</td> <td>31 (68)</td> </tr> </tbody> </table>	Model	Leakage current (mA)	Mass kg (lb)	TF3150C-TX	5.5	31 (68)					
Model	Leakage current (mA)	Mass kg (lb)										
TF3150C-TX	5.5	31 (68)										

# Peripheral Equipment

## ● Power factor improvement DC reactor (FR-BEL)

This reactor enables users to boost the servo amplifier's power factor and reduce its power supply capacity.

As compared to the AC reactor, the DC reactor is more recommended since the DC reactor is more effective in power factor improvement, smaller and lighter, and its wiring is easier. (The DC reactor uses 2 wires, while the AC reactor uses 6 wires.)

Model	Applicable servo amplifier	Fig.
FR-BEL-0.4K	MR-J3-10A/B/T	A
FR-BEL-0.75K	MR-J3-20A/B/T	
FR-BEL-1.5K	MR-J3-40A/B/T	
FR-BEL-2.2K	MR-J3-60A/B/T	
FR-BEL-3.7K	MR-J3-70A/B/T	
FR-BEL-7.5K	MR-J3-100A/B/T	
FR-BEL-11K	MR-J3-200A/B/T	
FR-BEL-H1.5K	MR-J3-500A/B/T4	
FR-BEL-H2.2K	MR-J3-60A4/B4/T4	
FR-BEL-H3.7K	MR-J3-100A4/B4/T4	
FR-BEL-H7.5K	MR-J3-200A4/B4/T4	
FR-BEL-H11K	MR-J3-350A4/B4/T4	

Model	Applicable servo amplifier or drive unit	Applicable converter unit	Fig.
FR-BEL-15K	MR-J3-700A/B/T	—	B
FR-BEL-22K	MR-J3-11KA/B/T	—	
FR-BEL-30K	MR-J3-15KA/B/T	—	
FR-BEL-H15K	MR-J3-22KA4/B4/T4	—	
FR-BEL-H22K	MR-J3-11KA4/B4/T4	—	
FR-BEL-H30K	MR-J3-15KA4/B4/T4	—	C
MR-DCL30K	MR-J3-DU30KA/B	MR-J3-CR55K	
MR-DCL37K	MR-J3-DU37KA/B	MR-J3-CR55K4	
MR-DCL30K-4	MR-J3-DU30KA4/B4		
MR-DCL37K-4	MR-J3-DU37KA4/B4		
MR-DCL45K-4	MR-J3-DU45KA4/B4		
MR-DCL55K-4	MR-J3-DU55KA4/B4		

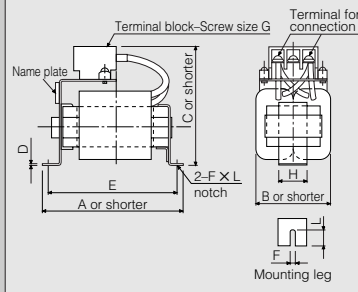
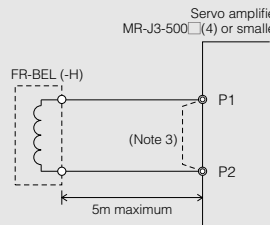
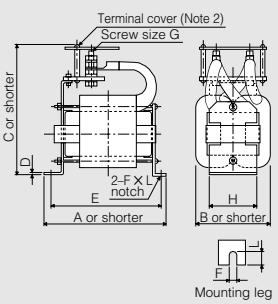
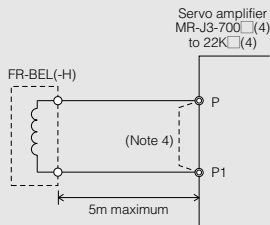
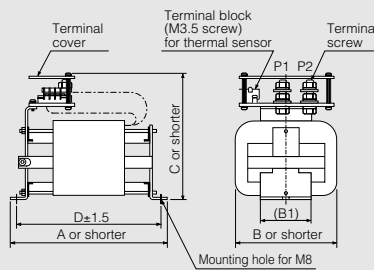
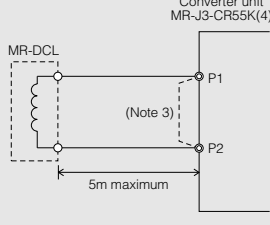
	External dimensions (Unit: mm)	Connections																																																																																																																																																																
A	 <table border="1"> <thead> <tr> <th>Model</th> <th colspan="8">Variable dimensions</th> <th>Mounting screw size</th> <th>Mass kg (lb)</th> <th>Wire size (mm<sup>2</sup>)</th> </tr> <tr> <th></th> <th>A</th> <th>B</th> <th>C</th> <th>D</th> <th>E</th> <th>FXL</th> <th>G</th> <th>H</th> <th></th> <th></th> <th></th> </tr> </thead> <tbody> <tr> <td>FR-BEL-0.4K</td> <td>110</td> <td>50</td> <td>94</td> <td>1.6</td> <td>95</td> <td>6 × 12</td> <td>M3.5</td> <td>25</td> <td>M5</td> <td>0.5 (1.1)</td> <td rowspan="5">2 (AWG14)</td> </tr> <tr> <td>FR-BEL-0.75K</td> <td>120</td> <td>53</td> <td>102</td> <td>1.6</td> <td>105</td> <td>6 × 12</td> <td>M4</td> <td>25</td> <td>M5</td> <td>0.7 (1.5)</td> </tr> <tr> <td>FR-BEL-1.5K</td> <td>130</td> <td>65</td> <td>110</td> <td>1.6</td> <td>115</td> <td>6 × 12</td> <td>M4</td> <td>30</td> <td>M5</td> <td>1.1 (2.4)</td> </tr> <tr> <td>FR-BEL-2.2K</td> <td>130</td> <td>65</td> <td>110</td> <td>1.6</td> <td>115</td> <td>6 × 12</td> <td>M4</td> <td>30</td> <td>M5</td> <td>1.2 (2.6)</td> </tr> <tr> <td>FR-BEL-3.7K</td> <td>150</td> <td>75</td> <td>102</td> <td>2.0</td> <td>135</td> <td>6 × 12</td> <td>M4</td> <td>40</td> <td>M5</td> <td>1.7 (3.7)</td> </tr> <tr> <td>FR-BEL-7.5K</td> <td>150</td> <td>75</td> <td>126</td> <td>2.0</td> <td>135</td> <td>6 × 12</td> <td>M5</td> <td>40</td> <td>M5</td> <td>2.3 (5.1)</td> <td rowspan="2">3.5 (AWG12)</td> </tr> <tr> <td>FR-BEL-11K</td> <td>170</td> <td>93</td> <td>132</td> <td>2.3</td> <td>155</td> <td>6 × 14</td> <td>M5</td> <td>50</td> <td>M5</td> <td>3.1 (6.8)</td> </tr> <tr> <td>FR-BEL-H1.5K</td> <td>130</td> <td>63</td> <td>89</td> <td>1.6</td> <td>115</td> <td>6 × 12</td> <td>M3.5</td> <td>32</td> <td>M5</td> <td>0.9 (2.0)</td> <td rowspan="2">2 (AWG14)</td> </tr> <tr> <td>FR-BEL-H2.2K</td> <td>130</td> <td>63</td> <td>101</td> <td>1.6</td> <td>115</td> <td>6 × 12</td> <td>M3.5</td> <td>32</td> <td>M5</td> <td>1.1 (2.4)</td> </tr> <tr> <td>FR-BEL-H3.7K</td> <td>150</td> <td>75</td> <td>102</td> <td>2.0</td> <td>135</td> <td>6 × 12</td> <td>M4</td> <td>40</td> <td>M5</td> <td>1.7 (3.7)</td> <td rowspan="3">5.5 (AWG10)</td> </tr> <tr> <td>FR-BEL-H7.5K</td> <td>150</td> <td>75</td> <td>124</td> <td>2.0</td> <td>135</td> <td>6 × 12</td> <td>M4</td> <td>40</td> <td>M5</td> <td>2.3 (5.1)</td> </tr> <tr> <td>FR-BEL-H11K</td> <td>170</td> <td>93</td> <td>132</td> <td>2.3</td> <td>155</td> <td>6 × 14</td> <td>M5</td> <td>50</td> <td>M5</td> <td>3.1 (6.8)</td> </tr> </tbody> </table>	Model	Variable dimensions								Mounting screw size	Mass kg (lb)	Wire size (mm <sup>2</sup> )		A	B	C	D	E	FXL	G	H				FR-BEL-0.4K	110	50	94	1.6	95	6 × 12	M3.5	25	M5	0.5 (1.1)	2 (AWG14)	FR-BEL-0.75K	120	53	102	1.6	105	6 × 12	M4	25	M5	0.7 (1.5)	FR-BEL-1.5K	130	65	110	1.6	115	6 × 12	M4	30	M5	1.1 (2.4)	FR-BEL-2.2K	130	65	110	1.6	115	6 × 12	M4	30	M5	1.2 (2.6)	FR-BEL-3.7K	150	75	102	2.0	135	6 × 12	M4	40	M5	1.7 (3.7)	FR-BEL-7.5K	150	75	126	2.0	135	6 × 12	M5	40	M5	2.3 (5.1)	3.5 (AWG12)	FR-BEL-11K	170	93	132	2.3	155	6 × 14	M5	50	M5	3.1 (6.8)	FR-BEL-H1.5K	130	63	89	1.6	115	6 × 12	M3.5	32	M5	0.9 (2.0)	2 (AWG14)	FR-BEL-H2.2K	130	63	101	1.6	115	6 × 12	M3.5	32	M5	1.1 (2.4)	FR-BEL-H3.7K	150	75	102	2.0	135	6 × 12	M4	40	M5	1.7 (3.7)	5.5 (AWG10)	FR-BEL-H7.5K	150	75	124	2.0	135	6 × 12	M4	40	M5	2.3 (5.1)	FR-BEL-H11K	170	93	132	2.3	155	6 × 14	M5	50	M5	3.1 (6.8)	
Model	Variable dimensions								Mounting screw size	Mass kg (lb)	Wire size (mm <sup>2</sup> )																																																																																																																																																							
	A	B	C	D	E	FXL	G	H																																																																																																																																																										
FR-BEL-0.4K	110	50	94	1.6	95	6 × 12	M3.5	25	M5	0.5 (1.1)	2 (AWG14)																																																																																																																																																							
FR-BEL-0.75K	120	53	102	1.6	105	6 × 12	M4	25	M5	0.7 (1.5)																																																																																																																																																								
FR-BEL-1.5K	130	65	110	1.6	115	6 × 12	M4	30	M5	1.1 (2.4)																																																																																																																																																								
FR-BEL-2.2K	130	65	110	1.6	115	6 × 12	M4	30	M5	1.2 (2.6)																																																																																																																																																								
FR-BEL-3.7K	150	75	102	2.0	135	6 × 12	M4	40	M5	1.7 (3.7)																																																																																																																																																								
FR-BEL-7.5K	150	75	126	2.0	135	6 × 12	M5	40	M5	2.3 (5.1)	3.5 (AWG12)																																																																																																																																																							
FR-BEL-11K	170	93	132	2.3	155	6 × 14	M5	50	M5	3.1 (6.8)																																																																																																																																																								
FR-BEL-H1.5K	130	63	89	1.6	115	6 × 12	M3.5	32	M5	0.9 (2.0)	2 (AWG14)																																																																																																																																																							
FR-BEL-H2.2K	130	63	101	1.6	115	6 × 12	M3.5	32	M5	1.1 (2.4)																																																																																																																																																								
FR-BEL-H3.7K	150	75	102	2.0	135	6 × 12	M4	40	M5	1.7 (3.7)	5.5 (AWG10)																																																																																																																																																							
FR-BEL-H7.5K	150	75	124	2.0	135	6 × 12	M4	40	M5	2.3 (5.1)																																																																																																																																																								
FR-BEL-H11K	170	93	132	2.3	155	6 × 14	M5	50	M5	3.1 (6.8)																																																																																																																																																								
B	 <table border="1"> <thead> <tr> <th>Model</th> <th colspan="8">Variable dimensions</th> <th>Mounting screw size</th> <th>Mass kg (lb)</th> <th>Wire size (mm<sup>2</sup>)</th> </tr> <tr> <th></th> <th>A</th> <th>B</th> <th>C</th> <th>D</th> <th>E</th> <th>FXL</th> <th>G</th> <th>H</th> <th></th> <th></th> <th></th> </tr> </thead> <tbody> <tr> <td>FR-BEL-15K</td> <td>170</td> <td>93</td> <td>170</td> <td>2.3</td> <td>155</td> <td>6 × 14</td> <td>M8</td> <td>56</td> <td>M5</td> <td>3.8 (8.4)</td> <td rowspan="2">8 (AWG8) 22 (AWG4) (Note 1)</td> </tr> <tr> <td>FR-BEL-22K</td> <td>185</td> <td>119</td> <td>182</td> <td>2.6</td> <td>165</td> <td>7 × 15</td> <td>M8</td> <td>70</td> <td>M6</td> <td>5.4 (12)</td> </tr> <tr> <td>FR-BEL-30K</td> <td>185</td> <td>119</td> <td>201</td> <td>2.6</td> <td>165</td> <td>7 × 15</td> <td>M8</td> <td>70</td> <td>M6</td> <td>6.7 (15)</td> <td>60 (AWG2/0)</td> </tr> <tr> <td>FR-BEL-H15K</td> <td>170</td> <td>93</td> <td>160</td> <td>2.3</td> <td>155</td> <td>6 × 14</td> <td>M6</td> <td>56</td> <td>M5</td> <td>3.7 (8.2)</td> <td>8 (AWG8)</td> </tr> <tr> <td>FR-BEL-H22K</td> <td>185</td> <td>119</td> <td>171</td> <td>2.6</td> <td>165</td> <td>7 × 15</td> <td>M6</td> <td>70</td> <td>M6</td> <td>5.0 (11)</td> <td>22 (AWG4)</td> </tr> <tr> <td>FR-BEL-H30K</td> <td>185</td> <td>119</td> <td>189</td> <td>2.6</td> <td>165</td> <td>7 × 15</td> <td>M6</td> <td>70</td> <td>M6</td> <td>6.7 (15)</td> <td>22 (AWG4)</td> </tr> </tbody> </table>	Model	Variable dimensions								Mounting screw size	Mass kg (lb)	Wire size (mm <sup>2</sup> )		A	B	C	D	E	FXL	G	H				FR-BEL-15K	170	93	170	2.3	155	6 × 14	M8	56	M5	3.8 (8.4)	8 (AWG8) 22 (AWG4) (Note 1)	FR-BEL-22K	185	119	182	2.6	165	7 × 15	M8	70	M6	5.4 (12)	FR-BEL-30K	185	119	201	2.6	165	7 × 15	M8	70	M6	6.7 (15)	60 (AWG2/0)	FR-BEL-H15K	170	93	160	2.3	155	6 × 14	M6	56	M5	3.7 (8.2)	8 (AWG8)	FR-BEL-H22K	185	119	171	2.6	165	7 × 15	M6	70	M6	5.0 (11)	22 (AWG4)	FR-BEL-H30K	185	119	189	2.6	165	7 × 15	M6	70	M6	6.7 (15)	22 (AWG4)																																																																		
Model	Variable dimensions								Mounting screw size	Mass kg (lb)	Wire size (mm <sup>2</sup> )																																																																																																																																																							
	A	B	C	D	E	FXL	G	H																																																																																																																																																										
FR-BEL-15K	170	93	170	2.3	155	6 × 14	M8	56	M5	3.8 (8.4)	8 (AWG8) 22 (AWG4) (Note 1)																																																																																																																																																							
FR-BEL-22K	185	119	182	2.6	165	7 × 15	M8	70	M6	5.4 (12)																																																																																																																																																								
FR-BEL-30K	185	119	201	2.6	165	7 × 15	M8	70	M6	6.7 (15)	60 (AWG2/0)																																																																																																																																																							
FR-BEL-H15K	170	93	160	2.3	155	6 × 14	M6	56	M5	3.7 (8.2)	8 (AWG8)																																																																																																																																																							
FR-BEL-H22K	185	119	171	2.6	165	7 × 15	M6	70	M6	5.0 (11)	22 (AWG4)																																																																																																																																																							
FR-BEL-H30K	185	119	189	2.6	165	7 × 15	M6	70	M6	6.7 (15)	22 (AWG4)																																																																																																																																																							
C	 <table border="1"> <thead> <tr> <th>Model</th> <th colspan="5">Variable dimensions</th> <th>Terminal screw size</th> <th>Mass kg (lb)</th> <th>Wire size (mm<sup>2</sup>)</th> </tr> <tr> <th></th> <th>A</th> <th>B</th> <th>B1</th> <th>C</th> <th>D</th> <th></th> <th></th> <th></th> </tr> </thead> <tbody> <tr> <td>MR-DCL30K</td> <td>255</td> <td>135</td> <td>80</td> <td>215</td> <td>232</td> <td>M12</td> <td>9.5 (21)</td> <td>60 (AWG2/0)</td> </tr> <tr> <td>MR-DCL37K</td> <td>255</td> <td>135</td> <td>80</td> <td>215</td> <td>232</td> <td>M12</td> <td>9.5 (21)</td> <td>80 (AWG3/0)</td> </tr> <tr> <td>MR-DCL30K-4</td> <td>205</td> <td>135</td> <td>75</td> <td>200</td> <td>175</td> <td>M8</td> <td>6.5 (14)</td> <td>30 (AWG2)</td> </tr> <tr> <td>MR-DCL37K-4</td> <td>225</td> <td>135</td> <td>80</td> <td>200</td> <td>197</td> <td>M8</td> <td>7 (15)</td> <td>38 (AWG2)</td> </tr> <tr> <td>MR-DCL45K-4</td> <td>240</td> <td>135</td> <td>80</td> <td>200</td> <td>212</td> <td>M8</td> <td>7.5 (17)</td> <td>50 (AWG1/0)</td> </tr> <tr> <td>MR-DCL55K-4</td> <td>260</td> <td>135</td> <td>80</td> <td>215</td> <td>232</td> <td>M8</td> <td>9.5 (21)</td> <td>60 (AWG2/0)</td> </tr> </tbody> </table>	Model	Variable dimensions					Terminal screw size	Mass kg (lb)	Wire size (mm <sup>2</sup> )		A	B	B1	C	D				MR-DCL30K	255	135	80	215	232	M12	9.5 (21)	60 (AWG2/0)	MR-DCL37K	255	135	80	215	232	M12	9.5 (21)	80 (AWG3/0)	MR-DCL30K-4	205	135	75	200	175	M8	6.5 (14)	30 (AWG2)	MR-DCL37K-4	225	135	80	200	197	M8	7 (15)	38 (AWG2)	MR-DCL45K-4	240	135	80	200	212	M8	7.5 (17)	50 (AWG1/0)	MR-DCL55K-4	260	135	80	215	232	M8	9.5 (21)	60 (AWG2/0)																																																																																									
Model	Variable dimensions					Terminal screw size	Mass kg (lb)	Wire size (mm <sup>2</sup> )																																																																																																																																																										
	A	B	B1	C	D																																																																																																																																																													
MR-DCL30K	255	135	80	215	232	M12	9.5 (21)	60 (AWG2/0)																																																																																																																																																										
MR-DCL37K	255	135	80	215	232	M12	9.5 (21)	80 (AWG3/0)																																																																																																																																																										
MR-DCL30K-4	205	135	75	200	175	M8	6.5 (14)	30 (AWG2)																																																																																																																																																										
MR-DCL37K-4	225	135	80	200	197	M8	7 (15)	38 (AWG2)																																																																																																																																																										
MR-DCL45K-4	240	135	80	200	212	M8	7.5 (17)	50 (AWG1/0)																																																																																																																																																										
MR-DCL55K-4	260	135	80	215	232	M8	9.5 (21)	60 (AWG2/0)																																																																																																																																																										

- Notes:
- When using FR-BEL15K, select a wire size 8mm<sup>2</sup> (AWG8) for MR-J3-700A/B/T; and 22mm<sup>2</sup> (AWG4) for MR-J3-11KA/B/T.
  - The terminal cover is supplied with the unit. Install the cover after connecting the wires.
  - When using the DC reactor, disconnect the short bar between P1 and P2.
  - When using the DC reactor, disconnect the short bar between P and P1.

## ● Power factor improvement AC reactor (FR-BAL)

This reactor enables users to boost the servo amplifier's power factor and reduce its power supply capacity.

Model	Applicable servo amplifier
FR-BAL-0.4K	MR-J3-10A/B/T, MR-J3-10A1/B1/T1
FR-BAL-0.75K	MR-J3-20A1/B1/T1 MR-J3-40A/B/T
FR-BAL-1.5K	MR-J3-40A1/B1/T1 MR-J3-60A/B/T MR-J3-70A/B/T
FR-BAL-2.2K	MR-J3-100A/B/T
FR-BAL-3.7K	MR-J3-200A/B/T
FR-BAL-7.5K	MR-J3-350A/B/T
FR-BAL-11K	MR-J3-500A/B/T
FR-BAL-15K	MR-J3-700A/B/T MR-J3-11KA/B/T
FR-BAL-22K	MR-J3-15KA/B/T
FR-BAL-30K	MR-J3-22KA/B/T

Model	Applicable servo amplifier
FR-BAL-H1.5K	MR-J3-60A4/B4/T4
FR-BAL-H2.2K	MR-J3-100A4/B4/T4
FR-BAL-H3.7K	MR-J3-200A4/B4/T4
FR-BAL-H7.5K	MR-J3-350A4/B4/T4
FR-BAL-H11K	MR-J3-500A4/B4/T4
FR-BAL-H15K	MR-J3-700A4/B4/T4 MR-J3-11KA4/B4/T4
FR-BAL-H22K	MR-J3-15KA4/B4/T4
FR-BAL-H30K	MR-J3-22KA4/B4/T4

External dimensions		(Unit: mm)		Connections					
Model	Variable dimensions						Mounting screw size	Terminal screw size	Mass
	W	W1	H	D	D1	C		kg (lb)	
FR-BAL-0.4K	135	120	115	59	45 <sup>0</sup> / <sub>-2.5</sub>	7.5	M4	M3.5	2.0 (4.4)
FR-BAL-0.75K	135	120	115	69	57 <sup>0</sup> / <sub>-2.5</sub>	7.5	M4	M3.5	2.8 (6.2)
FR-BAL-1.5K	160	145	140	71	55 <sup>0</sup> / <sub>-2.5</sub>	7.5	M4	M3.5	3.7 (8.2)
FR-BAL-2.2K	160	145	140	91	75 <sup>0</sup> / <sub>-2.5</sub>	7.5	M4	M3.5	5.6 (12)
FR-BAL-3.7K	220	200	192	90	70 <sup>0</sup> / <sub>-2.5</sub>	10	M5	M4	8.5 (19)
FR-BAL-7.5K	220	200	194	120	100 <sup>0</sup> / <sub>-2.5</sub>	10	M5	M5	14.5 (32)
FR-BAL-11K	280	255	220	135	100 <sup>0</sup> / <sub>-2.5</sub>	12.5	M6	M6	19 (42)
FR-BAL-15K	295	270	275	133	110 <sup>0</sup> / <sub>-2.5</sub>	12.5	M6	M6	27 (60)
FR-BAL-22K	290	240	301	199	170±5	25	M8	M8	35 (77)
FR-BAL-30K	290	240	301	219	190±5	25	M8	M8	43 (95)
FR-BAL-H1.5K	160	145	140	87	70 <sup>0</sup> / <sub>-2.5</sub>	7.5	M4	M3.5	5.3 (12)
FR-BAL-H2.2K	160	145	140	91	75 <sup>0</sup> / <sub>-2.5</sub>	7.5	M4	M3.5	5.9 (13)
FR-BAL-H3.7K	220	200	190	90	70 <sup>0</sup> / <sub>-2.5</sub>	10	M5	M3.5	8.5 (19)
FR-BAL-H7.5K	220	200	192	120	100±5	10	M5	M4	14 (31)
FR-BAL-H11K	280	255	226	130	100±5	12.5	M6	M5	18.5 (41)
FR-BAL-H15K	295	270	244	130	110±5	12.5	M6	M5	27 (60)
FR-BAL-H22K	290	240	269	199	170±5	25	M8	M8	35 (77)
FR-BAL-H30K	290	240	290	219	190±5	25	M8	M8	43 (95)

# Peripheral Equipment

## ● Electrical wires, circuit breakers, magnetic contactors (example of selection)

The following are examples of wire sizes when 600V polyvinyl chloride insulated wires with a length of 30m are used.

### <Servo amplifier 22kW or smaller>

Servo amplifier	Circuit breaker	Magnetic contactor	Electrical wire size (mm <sup>2</sup> )							
			L1, L2, L3, ⊕ (Note 1)	L11, L21	U, V, W, ⊕	P, C (Note 1)	B1, B2	BU, BV, BW	OHS1, OHS2	
MR-J3-10A(1)/B(1)/T(1)	30A frame 5A	S-N10	2 (AWG14)	1.25 (AWG16)	2 (AWG14)	2 (AWG14)	1.25 (AWG16)	—	—	
MR-J3-20A/B/T										
MR-J3-20A1/B1/T1	30A frame 10A									
MR-J3-40A/B/T										
MR-J3-40A1/B1/T1	30A frame 15A									
MR-J3-60A/B/T										
MR-J3-70A/B/T										
MR-J3-100A/B/T	30A frame 20A	S-N18			2 (AWG14)					
MR-J3-200A/B/T	30A frame 30A	S-N20	3.5 (AWG12)		3.5 (AWG12)					
MR-J3-500A/B/T (Note5)	50A frame 50A	S-N35	5.5 (AWG10)		5.5 (AWG10)					
MR-J3-700A/B/T (Note5)	100A frame 75A	S-N50	8 (AWG8)	1.25 (AWG16)	8 (AWG8)	3.5 (AWG12)	1.25 (AWG16)	2 (AWG14)	1.25 (AWG16)	
MR-J3-11KA/B/T (Note5)	100A frame 100A	S-N65	14 (AWG6)		22 (AWG4)	5.5 (AWG10)		2 (AWG14)	2 (AWG14)	1.25 (AWG16)
MR-J3-15KA/B/T (Note5)	225A frame 125A	S-N95	22 (AWG4)		30 (AWG2)					
MR-J3-22KA/B/T (Note5)	225A frame 175A	S-N125	50 (AWG1/0)		60 (AWG2/0)					
MR-J3-60A4/B4/T4	30A frame 5A	S-N10	2 (AWG14)		1.25 (AWG16)	2 (AWG14)		2 (AWG14)	—	—
MR-J3-100A4/B4/T4	30A frame 10A									
MR-J3-200A4/B4/T4	30A frame 15A									
MR-J3-350A4/B4/T4	30A frame 20A	S-N18	5.5 (AWG10)	5.5 (AWG10)	5.5 (AWG10)	5.5 (AWG10)	2 (AWG14)	2 (AWG14)	1.25 (AWG16)	
MR-J3-500A4/B4/T4 (Note5)	30A frame 30A									
MR-J3-700A4/B4/T4 (Note5)	50A frame 40A	S-N20	8 (AWG8)	8 (AWG8)	3.5 (AWG12)	3.5 (AWG12)	2 (AWG14)	1.25 (AWG16)		
MR-J3-11KA4/B4/T4 (Note5)	60A frame 60A	S-N25	14 (AWG6)	22 (AWG4)	5.5 (AWG10)	5.5 (AWG10)	2 (AWG14)	1.25 (AWG16)		
MR-J3-15KA4/B4/T4 (Note5)	100A frame 75A	S-N35								
MR-J3-22KA4/B4/T4 (Note5)	225A frame 125A	S-N65								

### <Drive unit 30kW or larger>

Drive unit	Applicable converter unit	Circuit breaker	Magnetic contactor	Electrical wire size (mm <sup>2</sup> )					
				L1, L2, L3, ⊕	L11, L21	U, V, W, ⊕	P2, C (Note 1)	BU, BV, BW	OHS1, OHS2
MR-J3-DU30KA/B (Note5)	MR-J3-CR55K	400A frame 250A	S-N150	50 (AWG1/0)	2 (AWG14)	60 (AWG2/0)	5.5 (AWG10)	2 (AWG14)	1.25 (AWG16)
MR-J3-DU37KA/B (Note5)		400A frame 300A	S-N180	60 (AWG2/0)		60 (AWG2/0)			
MR-J3-DU30KA4/B4 (Note5)	MR-J3-CR55K4	225A frame 150A	S-N95	22 (AWG4)	2 (AWG14)	30 (AWG2)	5.5 (AWG10)	1.25 (AWG16)	1.25 (AWG16)
MR-J3-DU37KA4/B4 (Note5)		225A frame 175A	S-N125	30 (AWG2)		38 (AWG2)			
MR-J3-DU45KA4/B4 (Note5)		225A frame 225A	S-N150	38 (AWG2)		50 (AWG1/0)			
MR-J3-DU55KA4/B4 (Note5)		400A frame 250A	S-N180	50 (AWG1/0)		60 (AWG2/0)			

- Notes: 1. Connect a reactor or an optional regeneration unit using the 5m or shorter length electrical wire. For the electrical wire size suitable for the power factor improvement DC reactor, refer to the section "Peripheral Equipment ● Power factor improvement DC reactor" in this catalog.
2. Use a fluoric resin wire (0.75mm<sup>2</sup> (AWG19)) when connecting to the HF-KP/HF-MP series motor power supply connector. Refer to "SERVO AMPLIFIER INSTRUCTION MANUAL" for details on wiring cables.
3. Use a fluoric resin wire (0.5mm<sup>2</sup> (AWG20)) when connecting to the HF-KP/HF-MP series motor electromagnetic brake connector. Refer to "SERVO AMPLIFIER INSTRUCTION MANUAL" for details on wiring cables.
4. The electrical wire size is for the servo motor with a cooling fan.
5. When connecting the wires to the terminal screws, be sure to use the screws attached to the terminal blocks.
6. This wire size applies when HIV wire (600V grade heat-resistant polyvinyl chloride insulated wire) with a length of 30m is used.

# Using a Personal Computer

## Servo support software

### <MR Configurator>

#### ● MRJW3-SETUP2□1E (Setup software)

This software makes it easy to perform setup, tuning, monitor display, diagnostics, reading and writing of parameters, and test operations with a personal computer. User-defined functions that enable a stable machine system, optimum control and short setup time are available.

#### ● Features

- (1) This software allows for easy set up and tuning the servo system with a personal computer.
- (2) Multiple monitor functions  
Graphic display functions are provided to display the servo motor status with the input signal triggers, such as the command pulse, droop pulse and speed.
- (3) Test operations with a personal computer  
Test operation of the servo motors can be performed with a personal computer using multiple test mode menus.
- (4) Further advanced tuning is possible with the improved advanced functions.



#### ● Specifications

Main-menu	Functions
Monitors	Batch display, input/output I/F display, high speed monitor, graph display
Alarms	Alarm display, alarm history, display of data that generated alarm
Diagnostics	Rotation failure reason display, system information display, tuning data display, absolute data display, axis name setting, amplifier diagnostic (Note)
Parameters	Parameter setting, device setting, tuning, display of change list, display of detailed information, converter, parameter copy
Test operations	JOG operation, positioning operation, operation without motor, forced digital output, program operation using simple language
Advanced function	Machine analyzer, gain search, machine simulation
Project	Project creation, reading or saving, various data reading, saving or printing
Others	Automatic operation, help display

Note: The amplifier diagnostic function is available only for MR-J3-□A□ and MR-J3-DU□A(4). The following versions are compatible with MR-J3-100A or smaller.

- Servo amplifier: Software Version A1 or above
- MR Configurator: MRJW3-SETUP211E Software Version A0 or above

## New functions! Selecting a variety of waveforms is now possible !

### [Graph] window (Note)

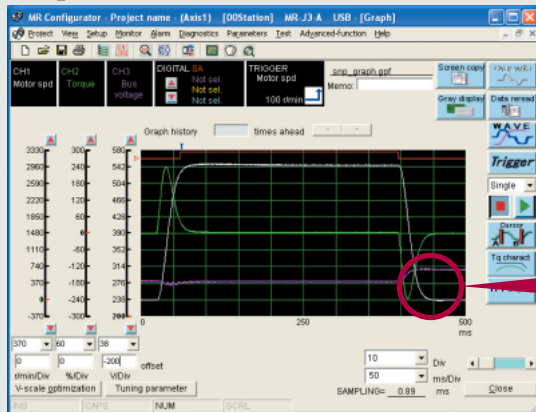

Powerful graph functions with 3 analog channels and 4 digital channels support tuning. User-friendly functions such as [Over write] and [Graph history] and a diverse waveform selection powerfully support user's work. Also, the [Gray display] function is provided for easy reading of printed data. Data can be saved either in CSV or JPEG format.

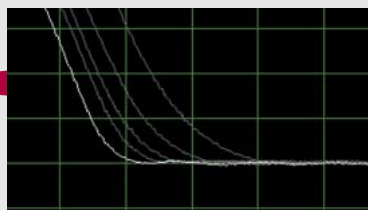

Example of using the [Over write] function in [Graph] window

## New functions!

### Example of using the [Torque characteristic diagram] function in [Graph] window (Note)

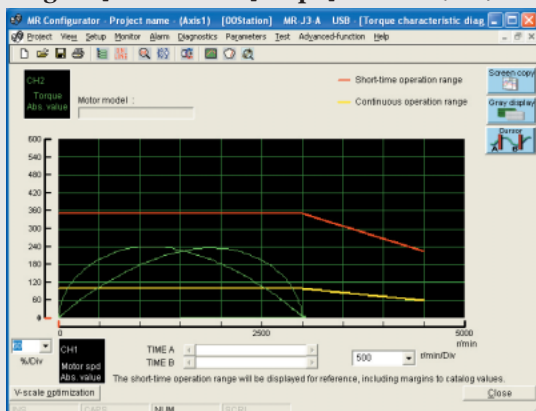

The speed-torque characteristic diagram of the motor in operation can be displayed using the [Torque characteristic diagram] function.

Since the actual operation status can be displayed on the servo motor torque characteristics diagram, the status of your servo system can be checked.

Note: The screens are for reference and may differ from the actual screens.

# Using a Personal Computer

## Improved accuracy!

[Machine analyzer operation] window (Note)

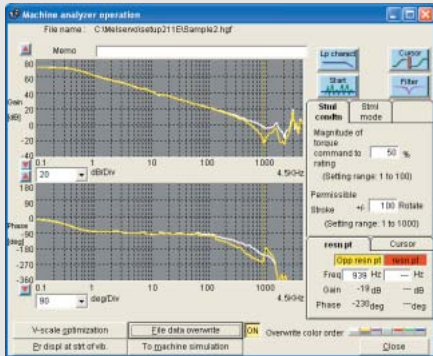

When the [Start] button is pressed, the servo motor is automatically oscillated, and the machine system's frequency characteristics are displayed.

The frequency characteristics that could previously only be analyzed in a range between 0.1 and 1kHz can now be analyzed in a range between 0.1 and 4.5kHz. Use this also as a tool to comprehend the machine system's characteristics. In addition, data can be overwritten.

## Improved usability!

[Parameter setting] window (Note)

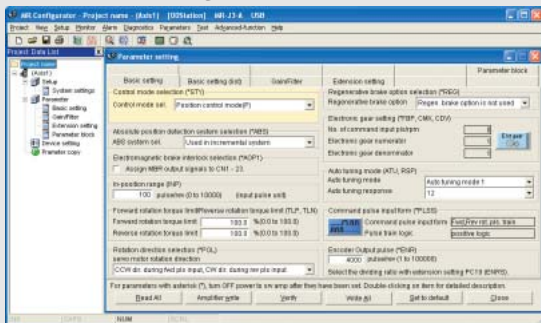

The [Parameter setting] window has been renewed. The basic setting parameters can be easily set in a selection format. Settings in the list format are also possible.

## Additional menus further improve usability!

[Test mode menu] window (Note)

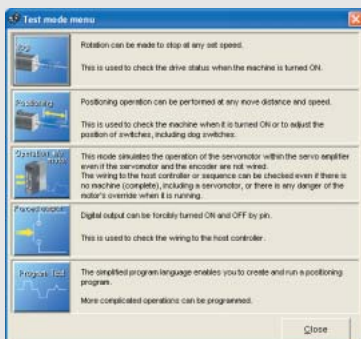

The test operation that matches the application can be selected from the multiple test mode menus.

## Improved usability!

[Gain search] window (Note)

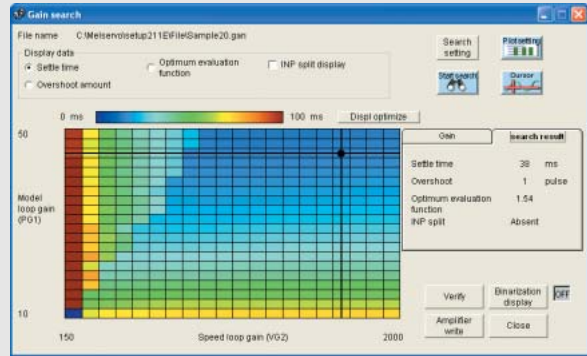

While automatically fluctuating the gain, the setup software "MR Configurator" searches for values with the shortest settling time and lowest overshooting or vibration. Ever-higher level tuning is now possible.

## Improved usability!

[Monitor] function:

[Amplifier Data Display] window (Note)



[Input/Output I/F Display] window (Note)

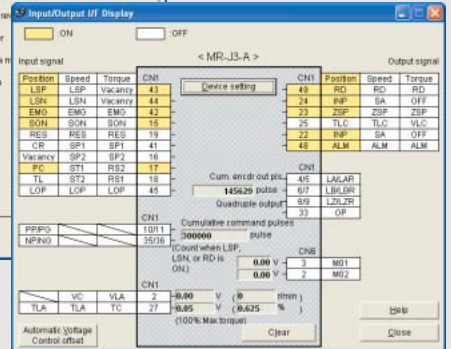

The [Input/Output I/F Display] window has been renewed. The [Input/Output I/F Display] window and [Amplifier Data Display] window can be displayed simultaneously, so the DI/DO ON/OFF status and operation status can be checked in real time.

## New functions!

[Amplifier diagnostic procedure] window (Note) (only for MR-J3-□A□ and MR-J3-DU□A(4))

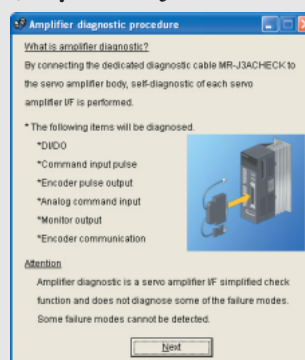

The amplifier diagnostic function has been newly added. The DI/DO signal, command pulse I/F and encoder pulse output are checked. If any fault is found, the amplifier's faulty section is pinpointed to speed up recovery.

The diagnostic cable (MR-J3ACHECK) is required.



## Servo support software

### <Capacity selection software>

#### ●MRJW3-MOTSZ111E

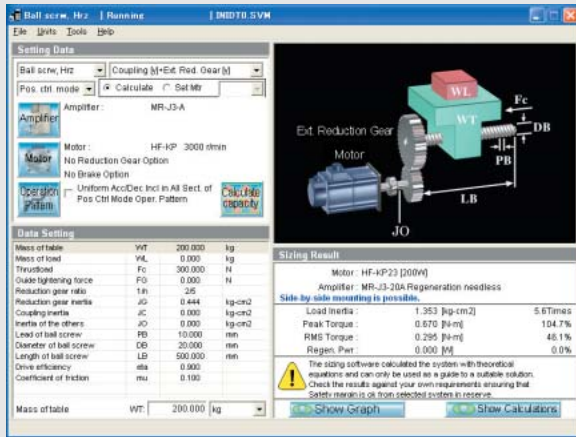

A user-friendly design facilitates selecting the optimum servo amplifier, servo motor (including the servo motor with an electromagnetic brake) and optional regeneration unit just by entering constants and an operation pattern into machine-specific windows.

#### Features

- (1) User-defined operation patterns can be set. The operation pattern can be selected from the position control mode operation or speed control mode operation. The selected operation pattern can be also displayed in the graph.
- (2) The feedrate (or motor speed) and torque can be displayed in the graph during the selection process.

\*The screen is for reference and may differ from the actual screen.

#### ● Specifications

Item	Description
Types of machine component	Horizontal ball screws, vertical ball screws, rack and pinions, roll feeds, rotating tables, dollies, elevators, material handling systems, other (direct inertia input) devices
Output of results	Parameter
	Printing
	Data storage
Inertia moment calculation function	Cylinder, core alignment column, variable speed, linear movement, suspension, conical, truncated cone

#### ● Compatible personal computer

IBM PC/AT compatible model running with the following operation conditions.

#### ● Operation conditions

Software		MR Configurator (Setup software) MRJW3-SETUP2□1E (Note 3)	Capacity selection software MRJW3-MOTSZ111E
Personal computer (Note 2)	OS (Note 1)		
	Windows® 95	×	○
	Windows® 98	○ (Note 4)	○
	Windows® Me	○	○
	Windows NT® Workstation4.0	×	○
	Windows® 2000 Professional	○	○
	Windows® XP Professional	○	○
Windows® XP Home Edition	○	○	
	Processor	Pentium®133MHz or more (Windows® 95, Windows® 98, Windows NT® Workstation4.0, Windows® 2000 Professional) Pentium®150MHz or more (Windows® Me) Pentium®300MHz or more (Windows® XP Professional, Windows® XP Home Edition)	
	Memory	16MB or more (Windows® 95) 24MB or more (Windows® 98) 32MB or more (Windows® Me, Windows NT® Workstation4.0, Windows® 2000 Professional) 128MB or more (Windows® XP Professional, Windows® XP Home Edition)	
	Free hard disk space	130MB or more	40MB or more
	Communication interface	Use serial port or USB port	—
	Monitor	Capable of resolution 800X600 or more, high Color (16-bit display)	
	Keyboard	Compatible with above personal computers.	
	Mouse	Compatible with above personal computers. Note that serial mice are incompatible.	
	Printer	Compatible with above personal computers.	
	Communication cable	MR-J3USBCBL3M	Not required

○ : Compatible × : Not compatible

- Notes: 1. Pentium is registered trademark of Intel Corporation. Windows and Windows NT are registered trademarks of Microsoft Corporation in the United States and other countries.  
 2. This software may not run correctly, depending on the personal computer being used.  
 3. MRJW3-SETUP211E is compatible only with the servo amplifiers MR-J3-350A or smaller. Use the MRJW3-SETUP221E for other amplifiers.  
 4. MRJW3-SETUP221E or above is compatible with Windows®98.

# Cautions Concerning Use

## To ensure safe use

- To use the products given in this catalog properly, always read the “Installation Guide” and “MR-J3 INSTRUCTION MANUAL” before starting to use them.
- These products have been manufactured as a general-purpose part for general industries, and have not been designed or manufactured to be incorporated in a device or system used in purposes related to human life.
- Before using the products for special purposes such as nuclear power, electric power, aerospace, medicine, passenger movement vehicles or underwater relays, contact Mitsubishi.
- These products have been manufactured under strict quality control. However, when installing the product where major accidents or losses could occur if the product fails, install appropriate backup or failsafe functions in the system.

## Cautions concerning use

### Transport and installation of motor

- Protect the motor or encoder from impact during handling. When installing a pulley or coupling, do not hammer on the shaft. Impact can damage the encoder. In the case of the motor with a key, install a pulley or coupling with the screw of shaft-end. Use a pulley extractor when taking off the pulley.



- Do not apply a load exceeding the tolerable load onto the servo motor shaft. The shaft could break.

### Installation

- Avoid installation in an environment in which oil mist, dust, etc. are in the air. When using in such an environment, enclose the servo amplifier in a sealed panel. Protect the motor by furnishing a cover for it or taking similar measures.
- Mount the amplifier vertically on a wall.
- When installing several amplifiers in a row in a sealed panel, leave 10mm or more open between each amplifier. The MR-J3-350□ or smaller servo amplifier can be installed closely. In this case, keep the ambient temperature within 0 to 45°C (32 to 113°F), or use them with 75% or less of the effective load rate.

When using one amplifier, always leave 40mm or more open in the upward and downward directions.

To ensure the life and reliability, keep space as open as possible toward the top plate so that heat does not build up. Take special care, especially when installing several amplifiers in a row.

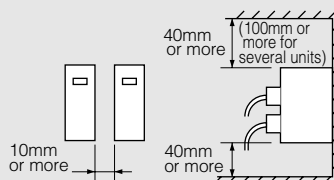

- For a single motor, the motor can be mounted horizontally or vertically. When mounting vertically (shaft-up), take measures on the machine-side to ensure that oil from the gear

box does not get into the motor.

- Do not touch the servo motor during or after operation until it has had sufficient time to cool. The motor could be very hot, and severe burns may result from touching the motor.
- The optional regeneration unit becomes hot (the temperature could be 100°C (212°F) or more) with frequent use. Do not install within flammable objects or objects subject to thermal deformation. Take care to ensure that electrical wires do not come into contact with the main unit.
- Carefully consider the cable clamping method, and make sure that bending stress and the stress of the cable's own weight are not applied on the cable connection section.
- If using in an application where the servo motor moves, select the cable bending radius according to the required bending life and wire type.

### Grounding

- Securely ground to prevent electric shocks and to stabilize the potential in the control circuit.
- To ground the servo motor and servo amplifier at one point, connect the grounding terminals of each unit, and ground from the servo amplifier side.
- Faults such as a deviation in position could occur if the grounding is insufficient.

### Wiring

- When a commercial power supply is applied to the amplifier's output terminals (U, V, W), the amplifier will be damaged. Before switching the power on, perform thorough wiring and sequence checks to ensure that there are no wiring errors, etc.
- When a commercial power supply is applied to the motor's input terminals (U, V, W), the motor will be damaged. Connect the motor to the amplifier's output terminals (U, V, W).
- Match the phase of the motor's input terminals (U, V, W) to the amplifier's output terminals (U, V, W) before connecting. If they are not the same, the motor control cannot be performed.
- Validate the stroke end signals (LSP, LSN) in the position control or speed control mode. The motor will not start if the signals are invalid.
- Do not apply excessive tension on the fiber-optic cable when cabling.
- The minimum bending radius of the fiber-optic cable is 25mm for MR-J3BUS□M and 50mm for MR-J3BUS□M-A/-B. If using these cables under the minimum bending radius, performance cannot be guaranteed.
- If the ends of the fiber-optic cable are dirty, the light will be obstructed, resulting in malfunctions. Always clean the ends if dirty.
- Do not tighten the fiber-optic cable with cable ties, etc.
- Do not directly look at the light when the fiber-optic cable is not connected.

## Factory settings

- All available motor and amplifier combinations are predetermined. Confirm the models of the motor and amplifier to be used before installation.
- For MR-J3-A, select a control mode of position, speed or torque control with the parameter PA01. Position control mode is selected as default. Change the parameter setting when using the other control modes.  
For MR-J3-B, the control mode is selected by the controller.
- When using the optional regeneration unit, change the parameter No.PA02. The optional regeneration unit is disabled as the default, so the parameter must be changed to increase the regeneration performance.

## Operation

- When a magnetic contactor (MC) is installed on the amplifier's primary side, do not perform frequent starts and stops with the MC. Doing so could cause the amplifier to fail.
- When trouble occurs, the amplifier's safety features are activated, halting output, and the dynamic brake instantly stops the motor. If free run is required, contact Mitsubishi about solutions involving servo amplifiers where the dynamic brake is not activated.
- When using a motor with an electromagnetic brake, do not apply the brake when the servo is on. Doing so may cause an amplifier overload or shorten brake life. Apply the brake when the servo is off.

## Cautions concerning model selection

- Select a motor with a rated torque above the continuous effective load torque.
- Design the operation pattern in the command section so that positioning can be completed, taking the stop setting time ( $t_s$ ) into account.

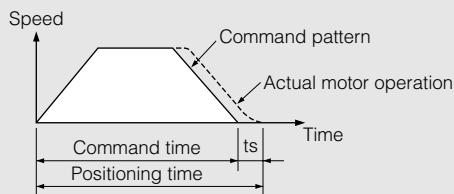

- The load inertia moment should be below the recommended load inertia moment ratio of the motor being used. If it is too large, desired performance may not be attainable.

## Warranty

### 1. Gratis warranty period and coverage

#### [Gratis warranty period]

Note that a period of less than one year after installation in your company or your customer's premises or within 18 months (counted from the date of production) after shipment from our company, whichever is shorter, is selected.

#### [Coverage]

##### (1) Diagnosis of failure

As a general rule, diagnosis of failure is done on site by the customer.

##### (2) Breakdown repairs

There will be a charge for breakdown repairs, exchange replacements and on site visits for the following four conditions.

- 1) Breakdowns due to improper storage or handling; careless accident; software/hardware design by your company and/or your customers.
- 2) Breakdowns due to modifications of the product without the consent of the manufacturer.
- 3) Breakdowns resulting from using the product outside the specified specifications of the product.
- 4) Breakdowns that are outside the terms of warranty.

Since the above services are limited to Japan, diagnosis of failures, etc. are not performed abroad.

For details, consult with Mitsubishi in advance.

### 2. Exclusion of opportunity loss from warranty liability

Regardless of the gratis warranty term, compensation for opportunity loss incurred to your company or your customers by failures of Mitsubishi products, for damages to the products other than Mitsubishi's or for other services are not covered under warranty.

### 3. Repair period after production is discontinued

Mitsubishi shall accept product repairs for seven years from the date of the products discontinuation.

### 4. Terms of delivery

Mitsubishi shall deliver the product to the customer, and Mitsubishi is not liable for on site adjustment or test run of the product.



 **Safety Warning**

To ensure proper use of the products listed in this catalog,  
please be sure to read the instruction manual prior to use.

 **MITSUBISHI ELECTRIC CORPORATION**  
HEAD OFFICE: TOKYO BLDG., 2-7-3, MARUNOUCHI, CHIYODA-KU, TOKYO 100-8310, JAPAN